

CALIFORNIA INSTITUTE OF TECHNOLOGY
Control and Dynamical Systems

CDS 101

Problem Set #5

R. M. Murray
Fall 2008

Issued: 3 Nov 08
Due: 10 Nov 08

Note: In the upper left hand corner of the *second* page of your homework set, please put the number of hours that you spent on this homework set (including reading).

1. Consider the block diagram for the following second-order system

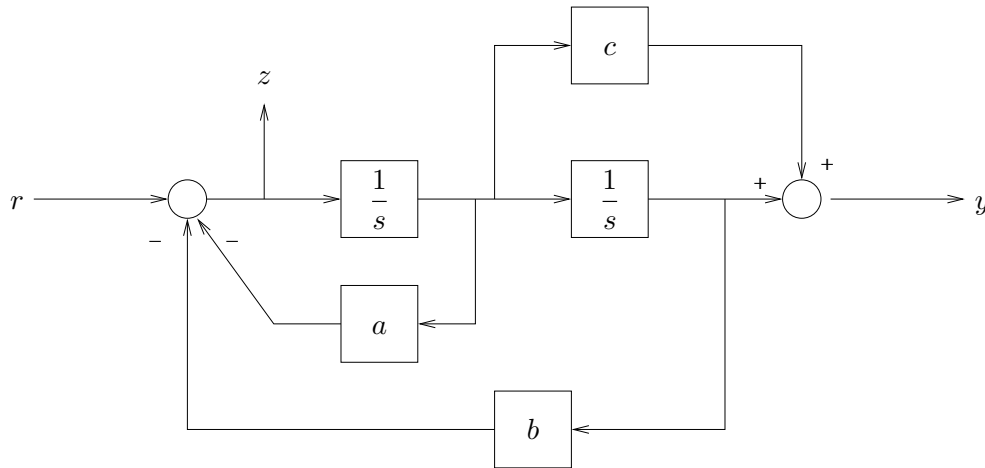

- (a) Compute the transfer function H_{yr} between the input r and the output y .
 (b) Show that the following state space system has the same transfer function, with the appropriate choice of parameters:

$$\frac{d}{dt} \begin{pmatrix} x_1 \\ x_2 \end{pmatrix} = \begin{pmatrix} 0 & 1 \\ -a_2 & -a_1 \end{pmatrix} \begin{pmatrix} x_1 \\ x_2 \end{pmatrix} + \begin{pmatrix} 0 \\ 1 \end{pmatrix} r$$

$$y = \begin{pmatrix} b_2 & b_1 \end{pmatrix} \begin{pmatrix} x_1 \\ x_2 \end{pmatrix} + dr$$

Give the values of a_i , b_i , and d that correspond to the transfer function you computed in (a).

- (c) Compute the transfer function H_{zr} between the input r and the output z . (Hint: It is *not* $H_{zr} = 1$.)
2. Consider the following simplified equations of motion for a cruise control system (these are a linearization of the equations from Section 3.1 in Åström and Murray):

$$m \frac{dv}{dt} = -cv + b\tau + F_{\text{hill}},$$

where $m = 1000$ kg is the mass of the vehicle, $c = 50$ N s/m is the viscous damping coefficient, $b = 25$ is the conversion factor between engine torque and the force applied to the vehicle.

We model the engine using a simple first-order equation

$$\frac{d\tau}{dt} = a(-\tau + Tu),$$

where $a = 0.2$ is the lag coefficient and $T = 200$ is the conversion factor between the throttle input and the steady state torque.

The simplest controller for this system is a proportional control, $u = k_p e$, where $e = (r - v)$ (r is the reference speed).

- (a) Draw a block diagram for the system, with the engine dynamics and the vehicle dynamics in separate blocks and represented by transfer functions. Label the reference input to the closed loop system as r , the disturbance due to the hill as d , and the output as y ($= v$).
- (b) (MATLAB) Construct the transfer functions H_{er} and H_{yd} for the closed loop system and use MATLAB to generate the step response (`step`) and frequency response (`bode`) for the each. Make sure to use the transfer function computation.
- (c) Consider a more sophisticated control law of the form

$$\frac{dx_c}{dt} = r - v, \quad u = k_p e + k_i x_c.$$

This control law contains an “integral” term, which uses the controller state x_c to integrate the error. Compute the transfer functions for this control law and redraw your block diagram from part (a) with the default controller replaced by this one.

- (d) (MATLAB) Using the default gains from previous homeworks ($k_p = 0.5$ and $k_i = 0.1$), use MATLAB to compute the transfer function from r to y and plot the step response and frequency response for the system.