



CDS 110: Lecture 1.2 Applications of Control



Richard M. Murray
29 September 2004

Goals:

- Describe modern engineering environment for control
- Survey engineering applications of control and key features
- Provide information on CDS 110 sections; explain schedule process
- Honor System discussion

Reading (available on course web page):

- Optional: R. Murray (ed), *Control in an Information Rich World*, 2003.

Control = Sensing + Computation + Actuation

In Feedback "Loop"

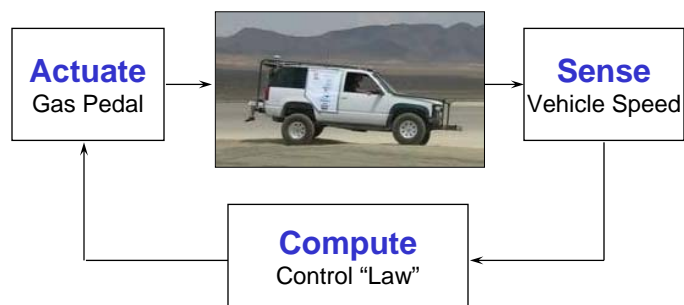

Goals

- Stability: system maintains desired operating point (hold steady speed)
- Performance: system responds rapidly to changes (accelerate to 6 m/sec)
- Robustness: system tolerates perturbations in dynamics (mass, drag, etc)

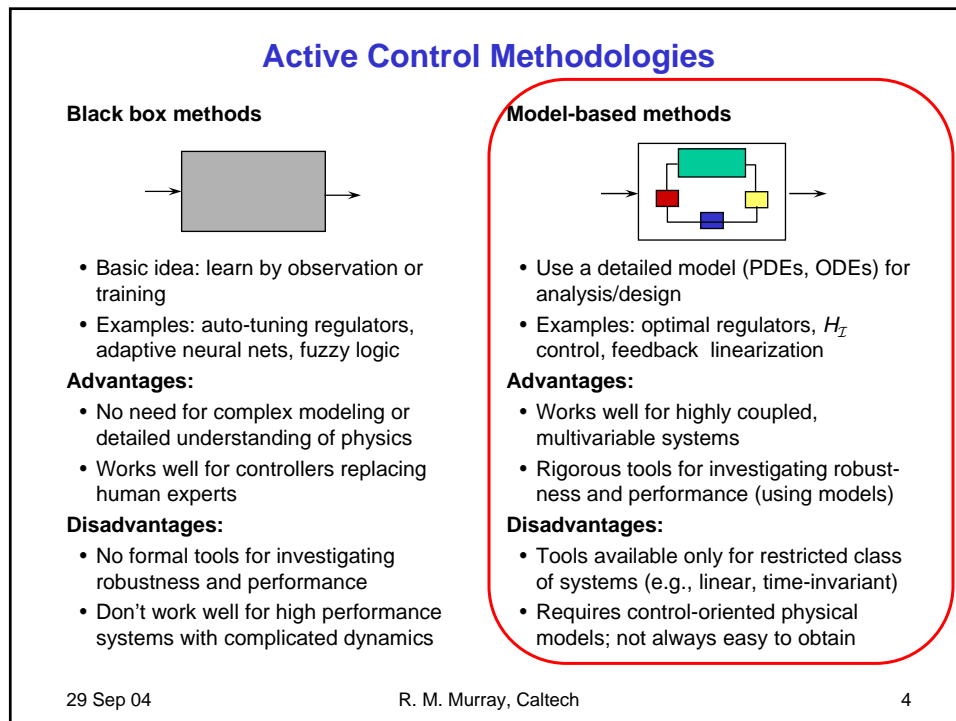
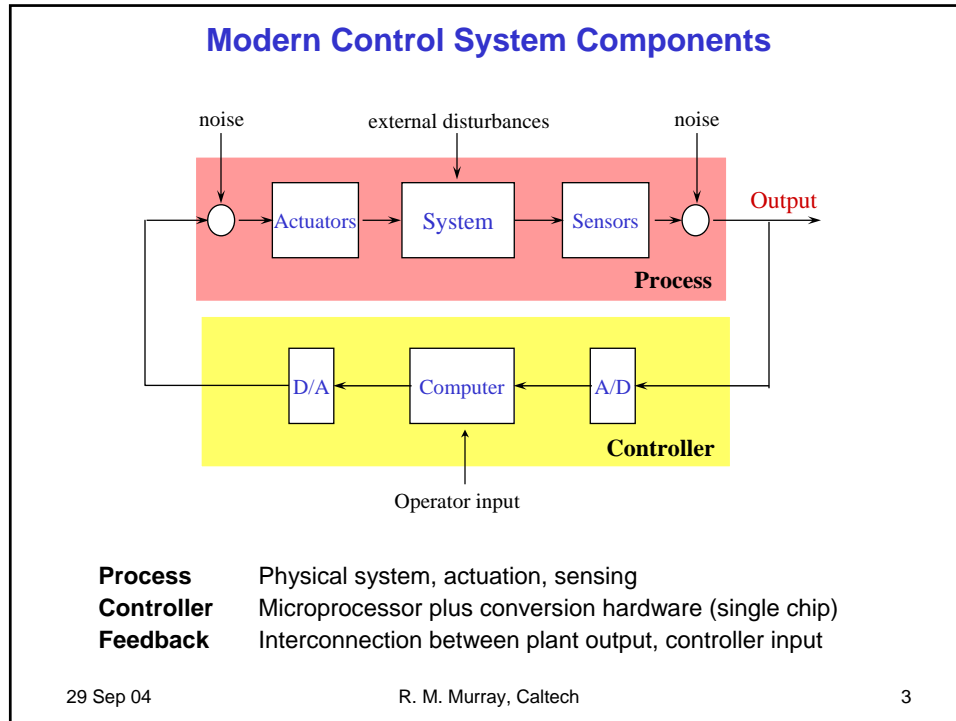

CDS 101/110 Course Sequence

<p>CDS 101 – Introduction to the <i>principles</i> and <i>tools</i> of control and feedback</p> <ul style="list-style-type: none"> • Summarize key concepts, w/ examples of fundamental principles at work • Introduce MATLAB-based tools for modeling, simulation, and analysis 	}	Fall
<p>CDS 110a – Analytical understanding of key concepts in control</p> <ul style="list-style-type: none"> • Detailed description of classical control and state space concepts • Provide knowledge to work with control engineers in a team setting 	}	Fall
<p>CDS 110b – Detailed design tools for control systems</p> <ul style="list-style-type: none"> • Estimation and robust control tools for <i>synthesis</i> of control laws 	}	Winter
<p>CDS 111 – Implementation of control systems for engineering applications</p>	}	Spring
<p>CDS Minor: CDS 110, CDS 140, senior thesis/project or Ae/CDS 125</p>		

29 Sep 03
R. M. Murray, Caltech CDS
5

CDS 110 Recitation Sections

<p>Goals</p> <ul style="list-style-type: none"> • Respond to 2003 feedback: more worked out examples • Provide more discipline-specific examples and discussion <p>Approach</p> <ul style="list-style-type: none"> • Weekly 1 hour meeting led by TA • Held after Wed lecture => reinforce concepts from class, answer questions • Each recitation will provide additional details on lectures + worked examples 	<p>Available sections</p> <ul style="list-style-type: none"> • Biomolecular and chemical processes • Information systems • Mechanical and aerospace systems • Electrical and electronic systems • Robotics and autonomous systems <p>How to sign up</p> <ul style="list-style-type: none"> • Fill out scheduling sheet <ul style="list-style-type: none"> ▫ List top 3 section choices ▫ List available times for section • Sections assignments will be announced on Monday • OK to attend a different section than you are assigned, if you prefer
--	---

Scheduling forms due by Friday (10/1) @ 5 pm

29 Sep 04
R. M. Murray, Caltech
6

Biomolecular and Chemical Processes

TAs: Domitilla Del Vecchio, Steve Chapman

Instructor: Anand Asthagiri

Application areas

- Chemical process control
- Biological feedback systems

Primary options: BE, Bio, ChE, MS

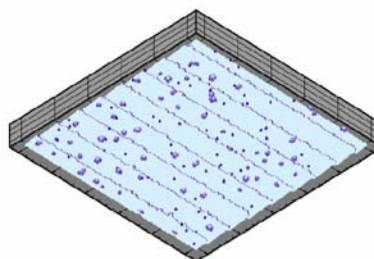
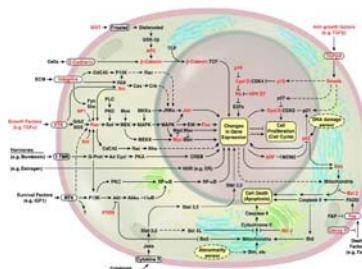

29 Sep 04

R. M. Murray, Caltech

7

Information Systems

TAs: Morr Mehyar, Kevin Tang

Instructor: Steven Low

Application areas

- Communications networks
- Software systems
- Economic systems

Primary options: CS, Ec, EE, SS



29 Sep 04

R. M. Murray, Caltech

8

Robotics and Autonomy

TAs: Haomiao Huang, Demetri Spanos

Instructor: Richard Murray

Application areas

- Autonomous robot systems
- Sensor-based navigation
- DARPA grand challenge

Primary options: CS, EE, ME

- Opportunities for hardware implementation on "Bob" or "Homer"

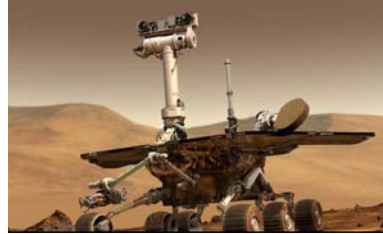

29 Sep 04

R. M. Murray, Caltech

11

CS/EE/ME 75 – Multi-Disciplinary Systems Engineering

Course Goals

- Provide an introduction to team-based *multi-disciplinary* engineering
- Introduce tools for coordinating work across a large group
- Design, build and document a complex engineering system

Approach

- Select a major project each year (ideally with some prize money)
- Link work in individual classes to CS/EE/ME 75 project
- First two terms focused on design (through individual classes)
- Bring entire team together third term (and summer) to complete the project

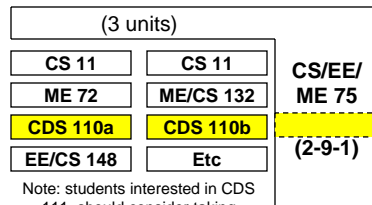

Note: students interested in CDS 111, should consider taking CS/EE/ME 75abc



See <http://www.cds.caltech.edu/~murray/dgc75> for more info and signup

29 Sep 04

R. M. Murray, Caltech

12

Honor System

What is it?

No member of the Caltech community shall take unfair advantage of any other member of the Caltech community

Why is it important?

- Provides a framework for ethical conduct in an academic setting
- Supports a *community* of scholars, working together to learn and educate
- Allows greater academic freedom through mutual trust and respect

How does it apply to this class?

- Homework: full collaboration allowed, but write up your own results
- Tests: take home, open book, limited time, non-proctored
- Violations: student centered – investigated by the BoC or GRB

Summary: Applications of Control

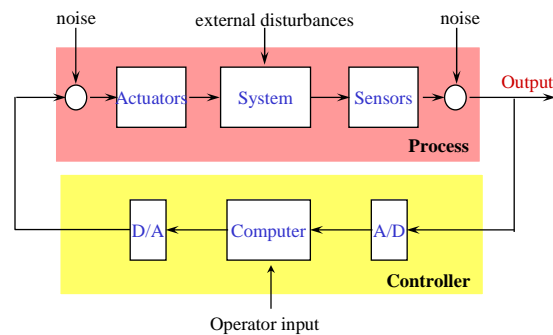

Modern applications of control

- Control = sensing, actuation and computation
- Digital control systems are increasingly common
- Applications across engineering and science



Molecular and chemical processes



Information Systems



Mechanical and Aero Systems



Electrical and Electronic Systems



Robotics and Autonomy