

---

---

# Feedback Systems

---

*An Introduction for Scientists and Engineers*  
*SECOND EDITION*

Karl Johan Åström  
Richard M. Murray

Version v3.0g (1 Nov 2015)

This is the electronic edition of *Feedback Systems* and is available from <http://www.cds.caltech.edu/~murray/FBS>. Hardcover editions may be purchased from Princeton University Press, <http://press.princeton.edu/titles/8701.html>.

This manuscript is for personal use only and may not be reproduced, in whole or in part, without written consent from the publisher (see <http://press.princeton.edu/permissions.html>).

PRINCETON UNIVERSITY PRESS  
PRINCETON AND OXFORD



---

---

# Contents

<b>Preface to the Second Edition</b>	<b>vii</b>
<b>Preface to the First Edition</b>	<b>ix</b>
<b>Chapter 1. Introduction</b>	<b>1-1</b>
1.1 What Is Feedback?	1-1
1.2 What Is Control?	1-3
1.3 Feedback Examples	1-5
1.4 Feedback Properties	1-11
1.5 Simple Forms of Feedback	1-17
1.6 Combining Feedback with Logic	1-19
1.7 Control System Architectures	1-23
1.8 Further Reading	1-26
Exercises	1-27
<b>Chapter 2. Feedback Principles</b>	<b>2-1</b>
2.1 Mathematical Models	2-1
2.2 Using Feedback to Improve Disturbance Attenuation	2-8
2.3 Using Feedback to Follow Command Signals	2-12
2.4 Using Feedback to Provide Robustness	2-15
2.5 Positive Feedback	2-18
2.6 Using Feedback to Shape Behavior	2-22
2.7 Feedback and Feedforward	2-26
2.8 Further Reading	2-30
Exercises	2-31
<b>Chapter 3. System Modeling</b>	<b>3-1</b>
3.1 Modeling Concepts	3-1
3.2 State Space Models	3-10
3.3 Modeling Methodology	3-22
3.4 Modeling Examples	3-30
3.5 Further Reading	3-40
Exercises	3-41
<b>Chapter 4. Examples</b>	<b>4-1</b>

4.1	Cruise Control	4-1
4.2	Bicycle Dynamics	4-5
4.3	Operational Amplifier Circuits	4-7
4.4	Computing Systems and Networks	4-11
4.5	Atomic Force Microscopy	4-17
4.6	Drug Administration	4-21
4.7	Population Dynamics	4-25
	Exercises	4-27
<b>Chapter 5. Dynamic Behavior</b>		<b>5-1</b>
5.1	Solving Differential Equations	5-1
5.2	Qualitative Analysis	5-4
5.3	Stability	5-8
5.4	Lyapunov Stability Analysis	5-17
5.5	Parametric and Nonlocal Behavior	5-27
5.6	Further Reading	5-32
	Exercises	5-33
<b>Chapter 6. Linear Systems</b>		<b>6-1</b>
6.1	Basic Definitions	6-1
6.2	The Matrix Exponential	6-6
6.3	Input/Output Response	6-15
6.4	Linearization	6-28
6.5	Further Reading	6-33
	Exercises	6-34
<b>Chapter 7. State Feedback</b>		<b>7-1</b>
7.1	Reachability	7-1
7.2	Stabilization by State Feedback	7-9
7.3	Design Considerations	7-17
7.4	Integral Action	7-30
7.5	Further Reading	7-32
	Exercises	7-32
<b>Chapter 8. Output Feedback</b>		<b>8-1</b>
8.1	Observability	8-1
8.2	State Estimation	8-6
8.3	Control Using Estimated State	8-11
8.4	Kalman Filtering	8-14
8.5	A General Controller Structure	8-19
8.6	Further Reading	8-26
	Exercises	8-27
<b>Chapter 9. Transfer Functions</b>		<b>9-1</b>

9.1	Frequency Domain Modeling	9-1
9.2	Determining the Transfer Function	9-3
9.3	Gain Poles and Zeros	9-13
9.4	Block Diagrams and Transfer Functions	9-18
9.5	The Bode Plot	9-24
9.6	Further Reading	9-33
	Exercises	9-34
<b>Chapter 10. Frequency Domain Analysis</b>		<b>10-1</b>
10.1	The Loop Transfer Function	10-1
10.2	The Nyquist Criterion	10-4
10.3	Stability Margins	10-12
10.4	Bode's Relations and Minimum Phase Systems	10-16
10.5	Generalized Notions of Gain and Phase	10-19
10.6	Further Reading	10-23
	Exercises	10-24
<b>Chapter 11. PID Control</b>		<b>11-1</b>
11.1	Basic Control Functions	11-1
11.2	Simple Controllers for Complex Systems	11-6
11.3	PID Tuning	11-10
11.4	Integrator Windup	11-14
11.5	Implementation	11-18
11.6	Further Reading	11-23
	Exercises	11-23
<b>Chapter 12. Frequency Domain Design</b>		<b>12-1</b>
12.1	Sensitivity Functions	12-1
12.2	Feedforward Design	12-5
12.3	Performance Specifications	12-8
12.4	Feedback Design via Loop Shaping	12-12
12.5	The Root-Locus Method	12-17
12.6	Fundamental Limitations	12-21
12.7	Design Example	12-30
12.8	Further Reading	12-33
	Exercises	12-34
<b>Chapter 13. Robust Performance</b>		<b>13-1</b>
13.1	Modeling Uncertainty	13-1
13.2	Stability in the Presence of Uncertainty	13-6
13.3	Performance in the Presence of Uncertainty	13-12
13.4	Robust Pole Placement	13-15
13.5	Design for Robust Performance	13-22
13.6	Further Reading	13-28

Exercises	13-29
<b>Chapter 14. Architecture and Design</b>	<b>14-1</b>
14.1 Bottom-Up Architectures	14-1
14.2 Top-Down Architectures	14-14
<b>Bibliography</b>	<b>B-1</b>
<b>Index</b>	<b>I-1</b>

---

---

## Preface to the Second Edition

The second edition of *Feedback Systems* contains a variety of changes that are based on feedback on the first edition, particularly in its use for introductory courses in control. One of the primary comments from users of the text was that the use of control tools for design purposes occurred only after several chapters of analytical tools, leaving the instructor having to try to convince students that the techniques would soon be useful. In our own teaching, we find that we often use design examples in the first few weeks of the class and use this to motivate the various techniques that follow. This approach has been particularly useful in engineering courses, where students are often eager to apply the tools to examples as part of gaining insight into the methods. We also found that universities that have a laboratory component attached to their controls class need to introduce some basic design techniques early, so that students can be implementing control laws in the laboratory in the early weeks of the course.

To help emphasize this more design-oriented flow, we have rearranged the material in the first third of the book. We have added a new chapter on “Feedback Principles” that illustrates some simple design principles and tools that can be used to show students what types of problems can be solved using feedback. This new chapter uses simple models, simulations and elementary analysis techniques, so that it should be accessible to students from a variety of engineering and scientific backgrounds. For courses in which students have already been exposed to the basic ideas of feedback, perhaps in an earlier discipline-specific course, this new chapter can easily be skipped without any loss of continuity.

We have also added a new chapter to the end of the book, focused on control architectures and design. Our intention in this chapter is to provide a systems view that describes how control design is integrated into a larger model-based development framework, motivated in part by our consulting activities with large companies. In this new chapter we also take the opportunity to present some overview material on “bottoms up” and “top down” approaches to control architectures, briefly introducing some of the many additional concepts from the field of control that are in widespread use in applications.

In addition to these relatively large changes, we have made many other smaller changes based on the feedback we have received from early adopters of the text. We have added some material on the Routh-Hurwitz criterion and root locus plots, to at least serve as “hooks” for instructors who wish to cover that material in more detail. We have also made some notational changes throughout, most notably changing the symbols for disturbance and noise signals to  $v$  and  $w$ , respectively.

The notation in the biological examples has also been updated to match the notation used in the textbook by Del Vecchio and Murray [DM14]. Finally, there are a variety of changes on the companion web site, including the addition of python code (using the python-control toolbox [Pyt]) for many of the examples.

We are indebted to numerous individuals who have taught out of the text and sent us feedback on changes that would better serve their needs. In addition to the many individuals listed in the preface to the first edition, we would like to also thank Constantine Caramanis, Clancy Rowley and André Tits for their feedback and insights.

Karl Johan Åström  
Lund, Sweden

Richard M. Murray  
Pasadena, California



---

---

## Preface to the First Edition

This book provides an introduction to the basic principles and tools for the design and analysis of feedback systems. It is intended to serve a diverse audience of scientists and engineers who are interested in understanding and utilizing feedback in physical, biological, information and social systems. We have attempted to keep the mathematical prerequisites to a minimum while being careful not to sacrifice rigor in the process. We have also attempted to make use of examples from a variety of disciplines, illustrating the generality of many of the tools while at the same time showing how they can be applied in specific application domains.

A major goal of this book is to present a concise and insightful view of the current knowledge in feedback and control systems. The field of control started by teaching everything that was known at the time and, as new knowledge was acquired, additional courses were developed to cover new techniques. A consequence of this evolution is that introductory courses have remained the same for many years, and it is often necessary to take many individual courses in order to obtain a good perspective on the field. In developing this book, we have attempted to condense the current knowledge by emphasizing fundamental concepts. We believe that it is important to understand why feedback is useful, to know the language and basic mathematics of control and to grasp the key paradigms that have been developed over the past half century. It is also important to be able to solve simple feedback problems using back-of-the-envelope techniques, to recognize fundamental limitations and difficult control problems and to have a feel for available design methods.

This book was originally developed for use in an experimental course at Caltech involving students from a wide set of backgrounds. The course was offered to undergraduates at the junior and senior levels in traditional engineering disciplines, as well as first- and second-year graduate students in engineering and science. This latter group included graduate students in biology, computer science and physics. Over the course of several years, the text has been classroom tested at Caltech and at Lund University, and the feedback from many students and colleagues has been incorporated to help improve the readability and accessibility of the material.

Because of its intended audience, this book is organized in a slightly unusual fashion compared to many other books on feedback and control. In particular, we introduce a number of concepts in the text that are normally reserved for second-year courses on control and hence often not available to students who are not control systems majors. This has been done at the expense of certain traditional topics, which we felt that the astute student could learn independently and are often

explored through the exercises. Examples of topics that we have included are non-linear dynamics, Lyapunov stability analysis, the matrix exponential, reachability and observability, and fundamental limits of performance and robustness. Topics that we have deemphasized include root locus techniques, lead/lag compensation and detailed rules for generating Bode and Nyquist plots by hand.



Several features of the book are designed to facilitate its dual function as a basic engineering text and as an introduction for researchers in natural, information and social sciences. The bulk of the material is intended to be used regardless of the audience and covers the core principles and tools in the analysis and design of feedback systems. Advanced sections, marked by the “dangerous bend” symbol shown here, contain material that requires a slightly more technical background, of the sort that would be expected of senior undergraduates in engineering. A few sections are marked by two dangerous bend symbols and are intended for readers with more specialized backgrounds, identified at the beginning of the section. To limit the length of the text, several standard results and extensions are given in the exercises, with appropriate hints toward their solutions.

To further augment the printed material contained here, a companion web site has been developed and is available from the publisher’s web page:

<http://www.cds.caltech.edu/~murray/amwiki>

The web site contains a database of frequently asked questions, supplemental examples and exercises, and lecture material for courses based on this text. The material is organized by chapter and includes a summary of the major points in the text as well as links to external resources. The web site also contains the source code for many examples in the book, as well as utilities to implement the techniques described in the text. Most of the code was originally written using MATLAB M-files but was also tested with LabView MathScript to ensure compatibility with both packages. Many files can also be run using other scripting languages such as Octave, SciLab, SysQuake and Xmath.

The first half of the book focuses almost exclusively on state space control systems. We begin in Chapter 3<sup>1</sup> with a description of modeling of physical, biological and information systems using ordinary differential equations and difference equations. Chapter 4 presents a number of examples in some detail, primarily as a reference for problems that will be used throughout the text. Following this, Chapter 5 looks at the dynamic behavior of models, including definitions of stability and more complicated nonlinear behavior. We provide advanced sections in this chapter on Lyapunov stability analysis because we find that it is useful in a broad array of applications and is frequently a topic that is not introduced until later in one’s studies.

The remaining three chapters of the first half of the book focus on linear systems, beginning with a description of input/output behavior in Chapter 6. In Chapter 7, we formally introduce feedback systems by demonstrating how state space control laws can be designed. This is followed in Chapter 8 by material on output

---

<sup>1</sup>Chapter numbers reflect those in the second edition.

feedback and estimators. Chapters 7 and 8 introduce the key concepts of reachability and observability, which give tremendous insight into the choice of actuators and sensors, whether for engineered or natural systems.

The second half of the book presents material that is often considered to be from the field of “classical control.” This includes the transfer function, introduced in Chapter 9, which is a fundamental tool for understanding feedback systems. Using transfer functions, one can begin to analyze the stability of feedback systems using frequency domain analysis, including the ability to reason about the closed loop behavior of a system from its open loop characteristics. This is the subject of Chapter 10, which revolves around the Nyquist stability criterion.

In Chapters 11 and 12, we again look at the design problem, focusing first on proportional-integral-derivative (PID) controllers and then on the more general process of loop shaping. PID control is by far the most common design technique in control systems and a useful tool for any student. The chapter on frequency domain design introduces many of the ideas of modern control theory, including the sensitivity function. In Chapter 13, we combine the results from the second half of the book to analyze some of the fundamental trade-offs between robustness and performance. This is also a key chapter illustrating the power of the techniques that have been developed and serving as an introduction for more advanced studies.

The book is designed for use in a 10- to 15-week course in feedback systems that provides many of the key concepts needed in a variety of disciplines. For a 10-week course, Chapters 1–3, 5–7 and 9–12 can each be covered in a week’s time, with the omission of some topics from the final chapters. A more leisurely course, spread out over 14–15 weeks, could cover the entire book, with 2 weeks on modeling (Chapters 3 and 2)—particularly for students without much background in ordinary differential equations—and 2 weeks on robust performance (Chapter 13).

The mathematical prerequisites for the book are modest and in keeping with our goal of providing an introduction that serves a broad audience. We assume familiarity with the basic tools of linear algebra, including matrices, vectors and eigenvalues. These are typically covered in a sophomore-level course on the subject, and the textbooks by Apostol [Apo69], Arnold [Arn87] and Strang [Str88] can serve as good references. Similarly, we assume basic knowledge of differential equations, including the concepts of homogeneous and particular solutions for linear ordinary differential equations in one variable. Apostol [Apo69] and Boyce and DiPrima [BD04] cover this material well. Finally, we also make use of complex numbers and functions and, in some of the advanced sections, more detailed concepts in complex variables that are typically covered in a junior-level engineering or physics course in mathematical methods. Apostol [Apo67] or Stewart [Ste02] can be used for the basic material, with Ahlfors [Ahl66], Marsden and Hoffman [MH98] or Saff and Snider [SS02] being good references for the more advanced material. We have chosen not to include appendices summarizing these various topics since there are a number of good books available.

One additional choice that we felt was important was the decision not to rely on a knowledge of Laplace transforms in the book. While their use is by far the

most common approach to teaching feedback systems in engineering, many students in the natural and information sciences may lack the necessary mathematical background. Since Laplace transforms are not required in any essential way, we have included them only in an advanced section intended to tie things together for students with that background. Of course, we make tremendous use of *transfer functions*, which we introduce through the notion of response to exponential inputs, an approach we feel is more accessible to a broad array of scientists and engineers. For classes in which students have already had Laplace transforms, it should be quite natural to build on this background in the appropriate sections of the text.

### Acknowledgments

The authors would like to thank the many people who helped during the preparation of this book. The idea for writing this book came in part from a report on future directions in control [Mur03] to which Stephen Boyd, Roger Brockett, John Doyle and Gunter Stein were major contributors. Kristi Morgansen and Hideo Mabuchi helped teach early versions of the course at Caltech on which much of the text is based, and Steve Waydo served as the head TA for the course taught at Caltech in 2003–2004 and provided numerous comments and corrections. Charlotta Johnson and Anton Cervin taught from early versions of the manuscript in Lund in 2003–2007 and gave very useful feedback. Other colleagues and students who provided feedback and advice include Leif Andersson, John Carson, K. Mani Chandy, Michel Charpentier, Domitilla Del Vecchio, Kate Galloway, Per Hagander, Toivo Henningson Perby, Joseph Hellerstein, George Hines, Tore Hägglund, Cole Lepine, Anders Rantzer, Anders Robertsson, Dawn Tilbury and Francisco Zabala. The reviewers for Princeton University Press and Tom Robbins at NI Press also provided valuable comments that significantly improved the organization, layout and focus of the book. Our editor, Vickie Kearn, was a great source of encouragement and help throughout the publishing process. Finally, we would like to thank Caltech, Lund University and the University of California at Santa Barbara for providing many resources, stimulating colleagues and students, and pleasant working environments that greatly aided in the writing of this book.

Karl Johan Åström  
Lund, Sweden  
Santa Barbara, California

Richard M. Murray  
Pasadena, California

---

# Chapter One

## Introduction

*Feedback is a central feature of life. The process of feedback governs how we grow, respond to stress and challenge, and regulate factors such as body temperature, blood pressure and cholesterol level. The mechanisms operate at every level, from the interaction of proteins in cells to the interaction of organisms in complex ecologies.*

M. B. Hoagland and B. Dodson, *The Way Life Works*, 1995 [HD95].

In this chapter we provide an introduction to the basic concept of *feedback* and the related engineering discipline of *control*. We focus on both historical and current examples, with the intention of providing the context for current tools in feedback and control. Much of the material in this chapter is adapted from a report on future directions in control [Mur03], and the authors gratefully acknowledge the contributions of Roger Brockett and Gunter Stein to portions of this chapter.

### 1.1 What Is Feedback?

A *dynamical system* is a system whose behavior changes over time, often in response to external stimulation or forcing. The term *feedback* refers to a situation in which two (or more) dynamical systems are connected together such that each system influences the other and their dynamics are thus strongly coupled. Simple causal reasoning about a feedback system is difficult because the first system influences the second and the second system influences the first, leading to a circular argument. This makes conventional causal reasoning difficult and it is necessary to analyze the system as a whole. A consequence of this is that the behavior of feedback systems is often counter-intuitive, and it is therefore necessary to resort to formal methods to understand them.

Figure 1.1 illustrates in block diagram form the idea of feedback. We often use

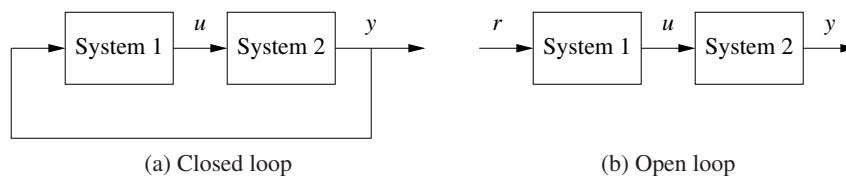

**Figure 1.1:** Open and closed loop systems. (a) The output of system 1 is used as the input of system 2, and the output of system 2 becomes the input of system 1, creating a closed loop system. (b) The interconnection between system 2 and system 1 is removed, and the system is said to be open loop.

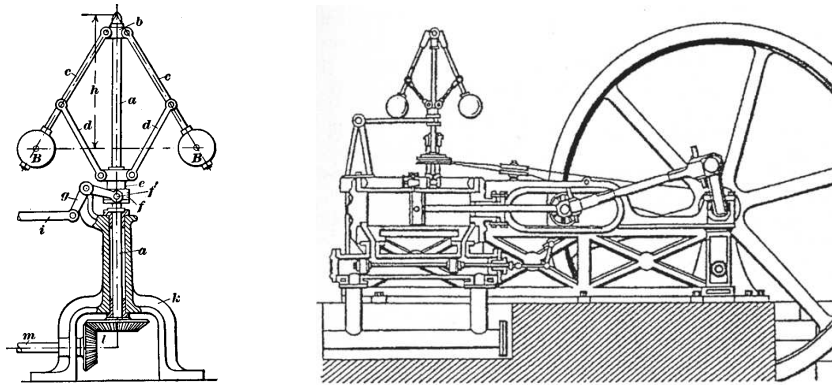

**Figure 1.2:** The centrifugal governor and the steam engine. The centrifugal governor on the left consists of a set of flyballs that spread apart as the speed of the engine increases. The steam engine on the right uses a centrifugal governor (above and to the left of the flywheel) to regulate its speed. (Credit: Machine a Vapeur Horizontale de Philip Taylor [1828].)

the terms *open loop* and *closed loop* when referring to such systems. A system is said to be a closed loop system if the systems are interconnected in a cycle, as shown in Figure 1.1a. If we break the interconnection, we refer to the configuration as an open loop system, as shown in Figure 1.1b.

As the quote at the beginning of this chapter illustrates, a major source of examples of feedback systems is biology. Biological systems make use of feedback in an extraordinary number of ways, on scales ranging from molecules to cells to organisms to ecosystems. One example is the regulation of glucose in the bloodstream through the production of insulin and glucagon by the pancreas. The body attempts to maintain a constant concentration of glucose, which is used by the body's cells to produce energy. When glucose levels rise (after eating a meal, for example), the hormone insulin is released and causes the body to store excess glucose in the liver. When glucose levels are low, the pancreas secretes the hormone glucagon, which has the opposite effect. Referring to Figure 1.1, we can view the liver as system 1 and the pancreas as system 2. The output from the liver is the glucose concentration in the blood, and the output from the pancreas is the amount of insulin or glucagon produced. The interplay between insulin and glucagon secretions throughout the day helps to keep the blood-glucose concentration constant, at about 90 mg per 100 mL of blood.

An early engineering example of a feedback system is a centrifugal governor, in which the shaft of a steam engine is connected to a flyball mechanism that is itself connected to the throttle of the steam engine, as illustrated in Figure 1.2. The system is designed so that as the speed of the engine increases (perhaps because of a lessening of the load on the engine), the flyballs spread apart and a linkage causes the throttle on the steam engine to be closed. This in turn slows down the engine, which causes the flyballs to come back together. We can model this system as a closed loop system by taking system 1 as the steam engine and system 2 as

the governor. When properly designed, the flyball governor maintains a constant speed of the engine, roughly independent of the loading conditions. The centrifugal governor was an enabler of the successful Watt steam engine, which fueled the industrial revolution.

Feedback has many interesting properties that can be exploited in designing systems. As in the case of glucose regulation or the flyball governor, feedback can make a system resilient toward external influences. It can also be used to create linear behavior out of nonlinear components, a common approach in electronics. More generally, feedback allows a system to be insensitive both to external disturbances and to variations in its individual elements.

Feedback has potential disadvantages as well. It can create dynamic instabilities in a system, causing oscillations or even runaway behavior. Another drawback, especially in engineering systems, is that feedback can introduce unwanted sensor noise into the system, requiring careful filtering of signals. It is for these reasons that a substantial portion of the study of feedback systems is devoted to developing an understanding of dynamics and a mastery of techniques in dynamical systems.

Feedback systems are ubiquitous in both natural and engineered systems. Control systems maintain the environment, lighting and power in our buildings and factories; they regulate the operation of our cars, consumer electronics and manufacturing processes; they enable our transportation and communications systems; and they are critical elements in our military and space systems. For the most part they are hidden from view, buried within the code of embedded microprocessors, executing their functions accurately and reliably. Feedback has also made it possible to increase dramatically the precision of instruments such as atomic force microscopes (AFMs) and telescopes.

In nature, homeostasis in biological systems maintains thermal, chemical and biological conditions through feedback. At the other end of the size scale, global climate dynamics depend on the feedback interactions between the atmosphere, the oceans, the land and the sun. Ecosystems are filled with examples of feedback due to the complex interactions between animal and plant life. Even the dynamics of economies are based on the feedback between individuals and corporations through markets and the exchange of goods and services.

## 1.2 What Is Control?

The term *control* has many meanings and often varies between communities. In this book, we define control to be the use of algorithms and feedback in engineered systems. Thus, control includes such examples as feedback loops in electronic amplifiers, setpoint controllers in chemical and materials processing, “fly-by-wire” systems on aircraft and even router protocols that control traffic flow on the Internet. Emerging applications include high-confidence software systems, autonomous vehicles and robots, real-time resource management systems and biologically engineered systems. At its core, control is an *information science* and includes the use of information in both analog and digital representations.

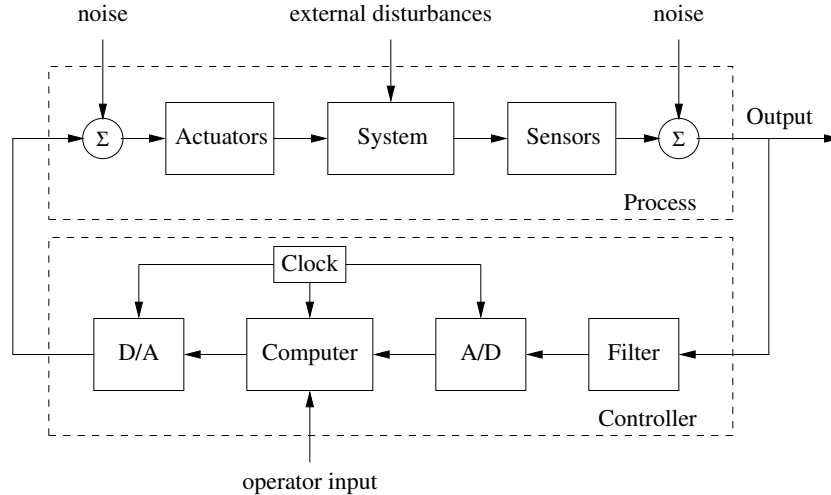

**Figure 1.3:** Components of a computer-controlled system. The upper dashed box represents the process dynamics, which include the sensors and actuators in addition to the dynamical system being controlled. Noise and external disturbances can perturb the dynamics of the process. The controller is shown in the lower dashed box. It consists of a filter and analog-to-digital (A/D) and digital-to-analog (D/A) converters, as well as a computer that implements the control algorithm. A system clock controls the operation of the controller, synchronizing the A/D, D/A and computing processes. The operator input is also fed to the computer as an external input.

A modern controller senses the operation of a system, compares it against the desired behavior, computes corrective actions based on a model of the system's response to external inputs and actuates the system to effect the desired change. This basic *feedback loop* of sensing, computation and actuation is the central concept in control. The key issues in designing control logic are ensuring that the dynamics of the closed loop system are stable (bounded disturbances give bounded errors) and that they have additional desired behavior (good disturbance attenuation, fast responsiveness to changes in operating point, etc). These properties are established using a variety of modeling and analysis techniques that capture the essential dynamics of the system and permit the exploration of possible behaviors in the presence of uncertainty, noise and component failure.

A typical example of a control system is shown in Figure 1.3. The basic elements of sensing, computation and actuation are clearly seen. In modern control systems, computation is typically implemented on a digital computer, requiring the use of analog-to-digital (A/D) and digital-to-analog (D/A) converters. Uncertainty enters the system through noise in sensing and actuation subsystems, external disturbances that affect the underlying system operation and uncertain dynamics in the system (parameter errors, unmodeled effects, etc). The algorithm that computes the control action as a function of the sensor values is often called a *control law*. The system can be influenced externally by an operator who introduces *command signals* to the system.



Control engineering relies on and shares tools from physics (dynamics and modeling), computer science (information and software) and operations research (optimization, probability theory and game theory), but it is also different from these subjects in both insights and approach.

Perhaps the strongest area of overlap between control and other disciplines is in the modeling of physical systems, which is common across all areas of engineering and science. One of the fundamental differences between control-oriented modeling and modeling in other disciplines is the way in which interactions between subsystems are represented. Control relies on a type of input/output modeling that allows many new insights into the behavior of systems, such as disturbance attenuation and stable interconnection. Model reduction, where a simpler (lower-fidelity) description of the dynamics is derived from a high-fidelity model, is also naturally described in an input/output framework. Perhaps most importantly, modeling in a control context allows the design of *robust* interconnections between subsystems, a feature that is crucial in the operation of all large engineered systems.

Control is also closely associated with computer science since virtually all modern control algorithms for engineering systems are implemented in software. However, control algorithms and software can be very different from traditional computer software because of the central role of the dynamics of the system and the real-time nature of the implementation.

### 1.3 Feedback Examples

Feedback has many interesting and useful properties. It makes it possible to design precise systems from imprecise components and to make relevant quantities in a system change in a prescribed fashion. An unstable system can be stabilized using feedback, and the effects of external disturbances can be reduced. Feedback also offers new degrees of freedom to a designer by exploiting sensing, actuation and computation. In this section we briefly survey some of the important applications and trends for feedback in the world around us. Considerably more detail is available in the 2003 report on future directions in control [Mur03] and in a companion article in the *IEEE Control Systems Magazine* [MÅB+03].

*Power Generation and Transmission.* Access to electrical power has been one of the major drivers of technological progress in modern society. Much of the early development of control was driven by the generation and distribution of electrical power. Control is mission critical for power systems, and there are many control loops in individual power stations. Control is also important for the operation of the whole power network since it is difficult to store energy and it is thus necessary to match production to consumption. Power management is a straightforward regulation problem for a system with one generator and one power consumer, but it is more difficult in a highly distributed system with many generators and long distances between consumption and generation. Power demand can change rapidly in an unpredictable manner and combining generators and consumers into large net-

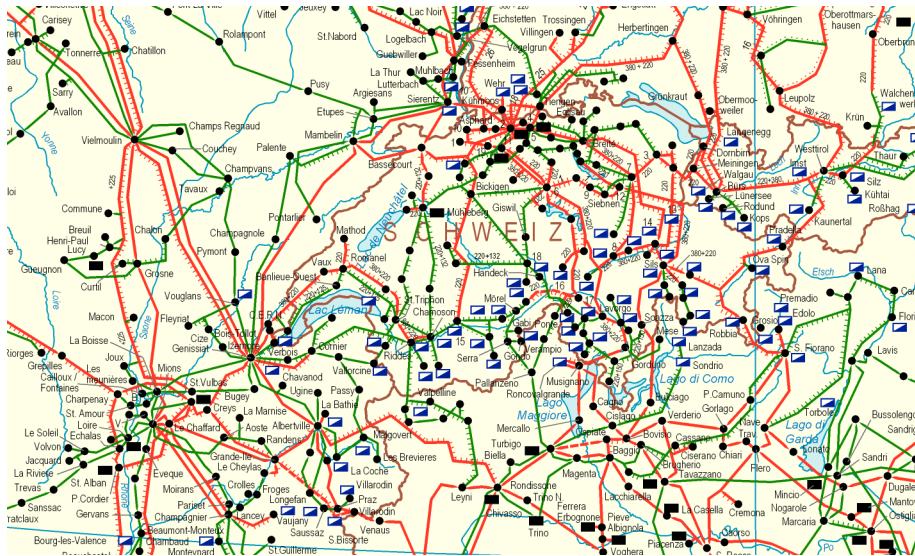
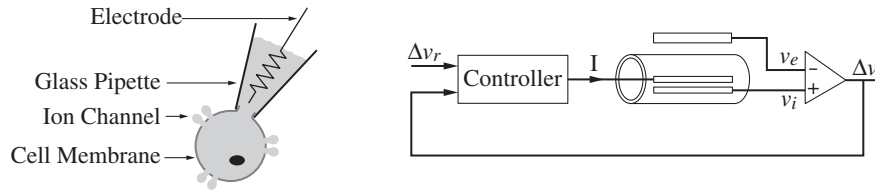

**Figure 1.4:** A small portion of the European power network. By 2008 European power suppliers will operate a single interconnected network covering a region from the Arctic to the Mediterranean and from the Atlantic to the Urals. In 2004 the installed power was more than 700 GW ( $7 \times 10^{11}$  W). (Source: UCTE [[www.ucte.org](http://www.ucte.org)])

works makes it possible to share loads among many suppliers and to average consumption among many customers. Large transcontinental and transnational power systems have therefore been built, such as the one shown in Figure 1.4.

*Aerospace and Transportation.* In aerospace, control has been a key technological capability tracing back to the beginning of the 20th century. Indeed, the Wright brothers are correctly famous not for demonstrating simply powered flight but *controlled* powered flight. Their early Wright Flyer incorporated moving control surfaces (vertical fins and canards) and warpable wings that allowed the pilot to regulate the aircraft's flight. In fact, the aircraft itself was not stable, so continuous pilot corrections were mandatory. This early example of controlled flight was followed by a fascinating success story of continuous improvements in flight control technology, culminating in the high-performance, highly reliable automatic flight control systems we see in modern commercial and military aircraft today.

*Materials and Processing.* The chemical industry is responsible for the remarkable progress in developing new materials that are key to our modern society. In addition to the continuing need to improve product quality, several other factors in the process control industry are drivers for the use of control. Environmental statutes continue to place stricter limitations on the production of pollutants, forcing the use of sophisticated pollution control devices. Environmental safety considerations have led to the design of smaller storage capacities to diminish the risk of major chemical leakage, requiring tighter control on upstream processes and, in some cases, supply chains. And large increases in energy costs have encouraged



**Figure 1.5:** The voltage clamp method for measuring ion currents in cells using feedback. A pipette is used to place an electrode in a cell (left and middle) and maintain the potential of the cell at a fixed level. The internal voltage in the cell is  $v_i$ , and the voltage of the external fluid is  $v_e$ . The feedback system (right) controls the current  $I$  into the cell so that the voltage drop across the cell membrane  $\Delta v = v_i - v_e$  is equal to its reference value  $\Delta v_r$ . The current  $I$  is then equal to the ion current.

engineers to design plants that are highly integrated, coupling many processes that used to operate independently. All of these trends increase the complexity of these processes and the performance requirements for the control systems, making control system design increasingly challenging.

*Instrumentation.* The measurement of physical variables is of prime interest in science and engineering. Consider, for example, an accelerometer, where early instruments consisted of a mass suspended on a spring with a deflection sensor. The precision of such an instrument depends critically on accurate calibration of the spring and the sensor. There is also a design compromise because a weak spring gives high sensitivity but low bandwidth. A different way of measuring acceleration is to use *force feedback*. The spring is replaced by a voice coil that is controlled so that the mass remains at a constant position. The acceleration is proportional to the current through the voice coil. In such an instrument, the precision depends entirely on the calibration of the voice coil and does not depend on the sensor, which is used only as the feedback signal. The sensitivity/bandwidth compromise is also avoided.

Another important application of feedback is in instrumentation for biological systems. Feedback is widely used to measure ion currents in cells using a device called a *voltage clamp*, which is illustrated in Figure 1.5. Hodgkin and Huxley used the voltage clamp to investigate propagation of action potentials in the giant axon of the squid. In 1963 they shared the Nobel Prize in Medicine with Eccles for “their discoveries concerning the ionic mechanisms involved in excitation and inhibition in the peripheral and central portions of the nerve cell membrane.” A refinement of the voltage clamp called a *patch clamp* made it possible to measure exactly when a single ion channel is opened or closed. This was developed by Neher and Sakmann, who received the 1991 Nobel Prize in Medicine “for their discoveries concerning the function of single ion channels in cells.”

*Robotics and Intelligent Machines.* The goal of cybernetic engineering, already articulated in the 1940s and even before, has been to implement systems capable of exhibiting highly flexible or “intelligent” responses to changing circumstances. In 1948 the MIT mathematician Norbert Wiener gave a widely read account of cy-



**Figure 1.6:** Autonomous vehicles. The figure on the left is a DJI Phantom 3 drone, which is able to maintain its position using GPS and inertial sensors. The figure on the right is an autonomous car that was developed by Google and is capable of driving on city streets by using sophisticated sensing and decision-making (control) software.

bernetics [Wie48]. A more mathematical treatment of the elements of engineering cybernetics was presented by H. S. Tsien in 1954, driven by problems related to the control of missiles [Tsi54]. Together, these works and others of that time form much of the intellectual basis for modern work in robotics and control.

Two recent areas of advancement in robotics and autonomous systems are (consumer) drones and autonomous cars, some examples of which are shown in Figure 1.6. Quadcopters such as the DJI Phantom make use of GPS receivers, accelerometers, magnetometers and gyros to provide stable flight, and also use stabilized camera platforms to provide high quality images and movies. Autonomous vehicles, such as the Google autonomous car project, make use of a variety of laser rangefinders, cameras and radars to perceive their environment and then use sophisticated decision-making and control algorithms to enable them to safely drive in a variety of traffic conditions, from high-speed freeways to crowded city streets.

*Networks and Computing Systems.* Control of networks is a large research area spanning many topics, including congestion control, routing, data caching and power management. Several features of these control problems make them very challenging. The dominant feature is the extremely large scale of the system; the Internet is probably the largest feedback control system humans have ever built. Another is the decentralized nature of the control problem: decisions must be made quickly and based only on local information. Stability is complicated by the presence of varying time lags, as information about the network state can be observed or relayed to controllers only after a delay, and the effect of a local control action can be felt throughout the network only after substantial delay.

Related to the control of networks is control of the servers that sit on these networks. Computers are key components of the systems of routers, web servers and database servers used for communication, electronic commerce, advertising and information storage. A typical example of a multilayer system for e-commerce is shown in Figure 1.7a. The system has several tiers of servers. The edge server accepts incoming requests and routes them to the HTTP server tier where they are parsed and distributed to the application servers. The processing for differ-

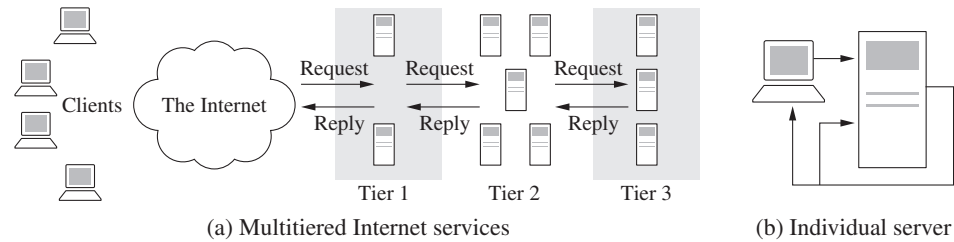

**Figure 1.7:** A multitier system for services on the Internet. In the complete system shown schematically in (a), users request information from a set of computers (tier 1), which in turn collect information from other computers (tiers 2 and 3). The individual server shown in (b) has a set of reference parameters set by a (human) system operator, with feedback used to maintain the operation of the system in the presence of uncertainty. (Based on Hellerstein et al. [HDPT04].)

ent requests can vary widely, and the application servers may also access external servers managed by other organizations. Control of an individual server in a layer is illustrated in Figure 1.7b. A quantity representing the quality of service or cost of operation—such as response time, throughput, service rate or memory usage—is measured in the computer. The control variables might represent incoming messages accepted, priorities in the operating system or memory allocation. The feedback loop then attempts to maintain quality-of-service variables within a target range of values.

*Economics.* The economy is a large, dynamical system with many actors: governments, organizations, companies and individuals. Governments control the economy through laws and taxes, the central banks by setting interest rates and companies by setting prices and making investments. Individuals control the economy through purchases, savings and investments. Many efforts have been made to model the system both at the macro level and at the micro level, but this modeling is difficult because the system is strongly influenced by the behaviors of the different actors in the system.

One of the reasons why it is difficult to model economic systems is that there are no conservation laws. A typical example is that the value of a company as expressed by its stock can change rapidly and erratically. There are, however, some areas with conservation laws that permit accurate modeling. One example is the flow of products from a manufacturer to a retailer as illustrated in Figure 1.8. The products are physical quantities that obey a conservation law, and the system can be modeled by accounting for the number of products in the different inventories. There are considerable economic benefits in controlling supply chains so that products are available to customers while minimizing products that are in storage. The real problems are more complicated than indicated in the figure because there may be many different products, there may be different factories that are geographically distributed and the factories may require raw material or subassemblies.

*Feedback in Nature.* Many problems in the natural sciences involve understanding

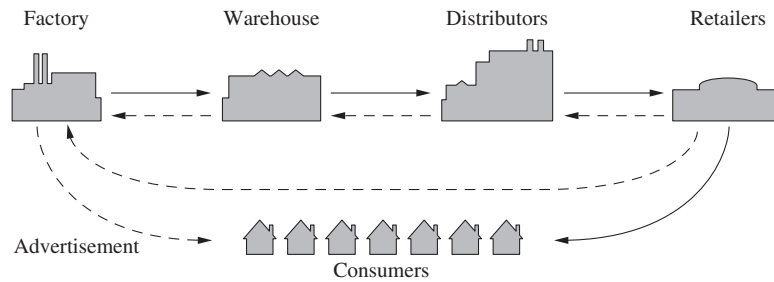
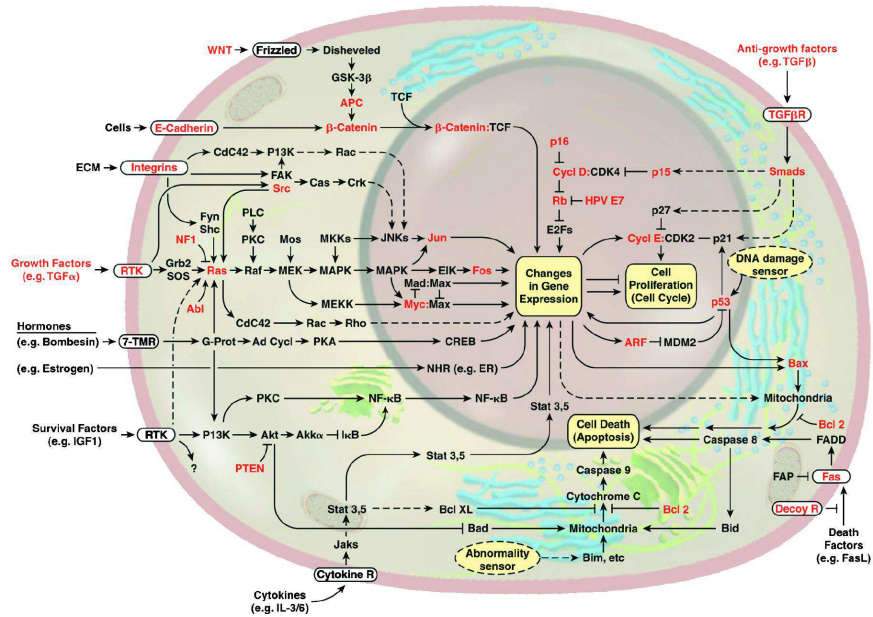

**Figure 1.8:** Supply chain dynamics (after Forrester [For61]). Products flow from the producer to the customer through distributors and retailers as indicated by the solid lines. There are typically many factories and warehouses and even more distributors and retailers. Multiple feedback loops are present as each agent tries to maintain the proper inventory level.

aggregate behavior in complex large-scale systems. This behavior emerges from the interaction of a multitude of simpler systems with intricate patterns of information flow. Representative examples can be found in fields ranging from embryology to seismology. Researchers who specialize in the study of specific complex systems often develop an intuitive emphasis on analyzing the role of feedback (or interconnection) in facilitating and stabilizing aggregate behavior. We briefly highlight three application areas here.

A major theme currently of interest to the biology community is the science of reverse (and eventually forward) engineering of biological control networks such as the one shown in Figure 1.9. There are a wide variety of biological phenomena that provide a rich source of examples of control, including gene regulation and signal transduction; hormonal, immunological and cardiovascular feedback mechanisms; muscular control and locomotion; active sensing, vision and proprioception; attention and consciousness; and population dynamics and epidemics. Each of these (and many more) provide opportunities to figure out what works, how it works, and what we can do to affect it.

In contrast to individual cells and organisms, emergent properties of aggregations and ecosystems inherently reflect selection mechanisms that act on multiple levels, and primarily on scales well below that of the system as a whole. Because ecosystems are complex, multiscale dynamical systems, they provide a broad range of new challenges for the modeling and analysis of feedback systems. Recent experience in applying tools from control and dynamical systems to bacterial networks suggests that much of the complexity of these networks is due to the presence of multiple layers of feedback loops that provide robust functionality to the individual cell. Yet in other instances, events at the cell level benefit the colony at the expense of the individual. Systems level analysis can be applied to ecosystems with the goal of understanding the robustness of such systems and the extent to which decisions and events affecting individual species contribute to the robustness and/or fragility of the ecosystem as a whole.



**Figure 1.9:** The wiring diagram of the growth-signaling circuitry of the mammalian cell [HW00]. The major pathways that are thought to play a role in cancer are indicated in the diagram. Lines represent interactions between genes and proteins in the cell. Lines ending in arrowheads indicate activation of the given gene or pathway; lines ending in a T-shaped head indicate repression. (Used with permission of Elsevier Ltd. and the authors.)

## 1.4 Feedback Properties

Feedback is a powerful idea which, as we have seen, is used extensively in natural and technological systems. The principle of feedback is simple: base correcting actions on the difference between desired and actual performance. In engineering, feedback has been rediscovered and patented many times in many different contexts. The use of feedback has often resulted in vast improvements in system capability, and these improvements have sometimes been revolutionary, as discussed above. The reason for this is that feedback has some truly remarkable properties. In this section we will discuss some of the properties of feedback that can be understood intuitively. This intuition will be formalized in subsequent chapters.

### Robustness to Uncertainty

One of the key uses of feedback is to provide robustness to uncertainty. By measuring the difference between the sensed value of a regulated signal and its desired value, we can supply a corrective action. If the system undergoes some change that affects the regulated signal, then we sense this change and try to force the system back to the desired operating point. This is precisely the effect that Watt exploited in his use of the centrifugal governor on steam engines.

As an example of this principle, consider the simple feedback system shown in

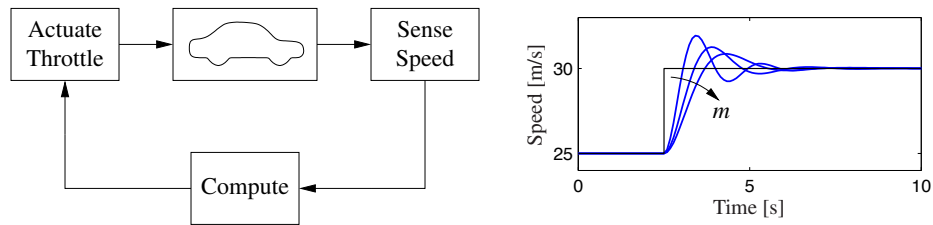

**Figure 1.10:** A feedback system for controlling the speed of a vehicle. In the block diagram on the left, the speed of the vehicle is measured and compared to the desired speed within the “Compute” block. Based on the difference in the actual and desired speeds, the throttle (or brake) is used to modify the force applied to the vehicle by the engine, drivetrain and wheels. The figure on the right shows the response of the control system to a commanded change in speed from 25 m/s to 30 m/s. The three different curves correspond to differing masses of the vehicle, between 1000 and 3000 kg, demonstrating the robustness of the closed loop system to a very large change in the vehicle characteristics.

Figure 1.10. In this system, the speed of a vehicle is controlled by adjusting the amount of gas flowing to the engine. Simple *proportional-integral* (PI) feedback is used to make the amount of gas depend on both the error between the current and the desired speed and the integral of that error. The plot on the right shows the results of this feedback for a step change in the desired speed and a variety of different masses for the car, which might result from having a different number of passengers or towing a trailer. Notice that independent of the mass (which varies by a factor of 3!), the steady-state speed of the vehicle always approaches the desired speed and achieves that speed within approximately 5 s. Thus the performance of the system is robust with respect to this uncertainty.

Another early example of the use of feedback to provide robustness is the negative feedback amplifier. When telephone communications were developed, amplifiers were used to compensate for signal attenuation in long lines. A vacuum tube was a component that could be used to build amplifiers. Distortion caused by the nonlinear characteristics of the tube amplifier together with amplifier drift were obstacles that prevented the development of line amplifiers for a long time. A major breakthrough was the invention of the feedback amplifier in 1927 by Harold S. Black, an electrical engineer at Bell Telephone Laboratories. Black used *negative feedback*, which reduces the gain but makes the amplifier insensitive to variations in tube characteristics. This invention made it possible to build stable amplifiers with linear characteristics despite the nonlinearities of the vacuum tube amplifier.

### Design of Dynamics

Another use of feedback is to change the dynamics of a system. Through feedback, we can alter the behavior of a system to meet the needs of an application: systems that are unstable can be stabilized, systems that are sluggish can be made responsive and systems that have drifting operating points can be held constant. Control theory provides a rich collection of techniques to analyze the stability and dynamic response of complex systems and to place bounds on the behavior of such



systems by analyzing the gains of linear and nonlinear operators that describe their components.

An example of the use of control in the design of dynamics comes from the area of flight control. The following quote, from a lecture presented by Wilbur Wright to the Western Society of Engineers in 1901 [McF53], illustrates the role of control in the development of the airplane:

Men already know how to construct wings or airplanes, which when driven through the air at sufficient speed, will not only sustain the weight of the wings themselves, but also that of the engine, and of the engineer as well. Men also know how to build engines and screws of sufficient lightness and power to drive these planes at sustaining speed ... Inability to balance and steer still confronts students of the flying problem ... When this one feature has been worked out, the age of flying will have arrived, for all other difficulties are of minor importance.

The Wright brothers thus realized that control was a key issue to enable flight. They resolved the compromise between stability and maneuverability by building an airplane, the Wright Flyer, that was unstable but maneuverable. The Flyer had a rudder in the front of the airplane, which made the plane very maneuverable. A disadvantage was the necessity for the pilot to keep adjusting the rudder to fly the plane: if the pilot let go of the stick, the plane would crash. Other early aviators tried to build stable airplanes. These would have been easier to fly, but because of their poor maneuverability they could not be brought up into the air. By using their insight and skillful experiments the Wright brothers made the first successful flight at Kitty Hawk in 1903.

Since it was quite tiresome to fly an unstable aircraft, there was strong motivation to find a mechanism that would stabilize an aircraft. Such a device, invented by Sperry, was based on the concept of feedback. Sperry used a gyro-stabilized pendulum to provide an indication of the vertical. He then arranged a feedback mechanism that would pull the stick to make the plane go up if it was pointing down, and vice versa. The Sperry autopilot was the first use of feedback in aeronautical engineering, and Sperry won a prize in a competition for the safest airplane in Paris in 1914. Figure 1.11 shows the Curtiss seaplane and the Sperry autopilot. The autopilot is a good example of how feedback can be used to stabilize an unstable system and hence “design the dynamics” of the aircraft.

One of the other advantages of designing the dynamics of a device is that it allows for increased modularity in the overall system design. By using feedback to create a system whose response matches a desired profile, we can hide the complexity and variability that may be present inside a subsystem. This allows us to create more complex systems by not having to simultaneously tune the responses of a large number of interacting components. This was one of the advantages of Black’s use of negative feedback in vacuum tube amplifiers: the resulting device had a well-defined linear input/output response that did not depend on the individ-

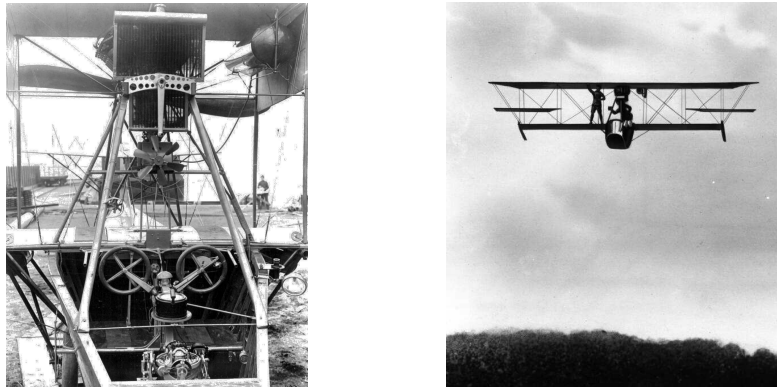
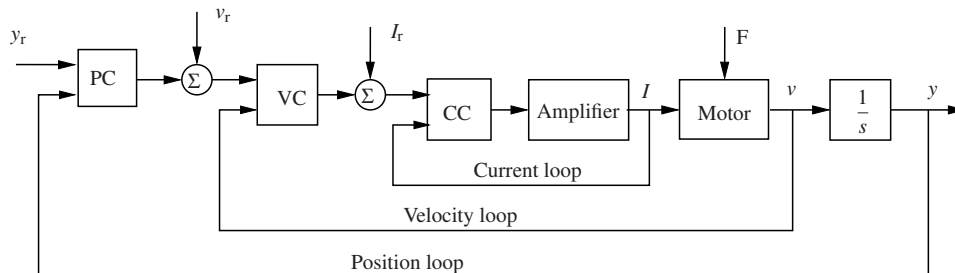

**Figure 1.11:** Aircraft autopilot system. The Sperry autopilot (left) contained a set of four gyros coupled to a set of air valves that controlled the wing surfaces. The 1912 Curtiss used an autopilot to stabilize the roll, pitch and yaw of the aircraft and was able to maintain level flight as a mechanic walked on the wing (right) [Hug93].

ual characteristics of the vacuum tubes being used.

### Creating Modularity

Feedback can be used to create modularity and shape well-defined relations between inputs and outputs in a structured hierarchical manner. A modular system is one in which individual components can be replaced without having to modify the entire system. By using feedback, it is possible to allow components to maintain their input/output properties in a manner that is robust to changes in its interconnections. A typical example is the electrical drive system shown in Figure 1.12, which has an architecture with three cascaded loops. The innermost loop is a current loop, the controller CC drives the amplifier so that the current to the motor follows the set point. The velocity loop with the controller VC drives the set point of the current controller so that velocity follows the set point of VC. The outer loop drives the set point of the velocity loop to follow the set point of the position controller



**Figure 1.12:** Block diagram of a system for position control. The system has three cascaded loops for control of current, velocity and position.

The control architecture with nested loops shown in Figure 1.12 is common. It simplifies both design, commissioning and operation. Consider for example the design of the velocity loop. With a well-designed current controller the motor current follows the set point of the controller independent of friction and other effects. Since the motor velocity is proportional to the current the dynamics relating velocity to the input of the current controller is approximately an integrator, because force is proportional to current and angular acceleration is proportional to force. The design of the velocity loop is then simple. With a well-designed velocity loop, the design of the position loop is also simple. The loops can also be tuned sequentially starting with the inner loop. The architecture illustrates how feedback can be used to simplify modeling and create modular systems.

### Drawbacks of Feedback

While feedback has many advantages, it also has some drawbacks. Chief among these is the possibility of instability if the system is not designed properly. We are all familiar with the effects of *positive feedback* when the amplification on a microphone is turned up too high in a room. This is an example of feedback instability, something that we obviously want to avoid. This is tricky because we must design the system not only to be stable under nominal conditions but also to remain stable under all possible perturbations of the dynamics.

In addition to the potential for instability, feedback inherently couples different parts of a system. One common problem is that feedback often injects measurement noise into the system. Measurements must be carefully filtered so that the actuation and process dynamics do not respond to them, while at the same time ensuring that the measurement signal from the sensor is properly coupled into the closed loop dynamics (so that the proper levels of performance are achieved).

Another potential drawback of control is the complexity of embedding a control system in a product. While the cost of sensing, computation and actuation has decreased dramatically in the past few decades, the fact remains that control systems are often complicated, and hence one must carefully balance the costs and benefits. An early engineering example of this is the use of microprocessor-based feedback systems in automobiles. The use of microprocessors in automotive applications began in the early 1970s and was driven by increasingly strict emissions standards, which could be met only through electronic controls. Early systems were expensive and failed more often than desired, leading to frequent customer dissatisfaction. It was only through aggressive improvements in technology that the performance, reliability and cost of these systems allowed them to be used in a transparent fashion. Even today, the complexity of these systems is such that it is difficult for an individual car owner to fix problems.

### Feedforward

Feedback is reactive: there must be an error before corrective actions are taken. However, in some circumstances it is possible to measure a disturbance before it

**Table 1.1:** Properties of feedback and feedforward

Feedback	Feedforward
Closed loop	Open loop
Acts on deviations	Acts on plans
Robust to model uncertainty	Sensitive to model uncertainty
Risk for instability	No risk for instability
Sensitive to measurement noise	Insensitive to measurement noise

enters the system, and this information can then be used to take corrective action before the disturbance has influenced the system. The effect of the disturbance is thus reduced by measuring it and generating a control signal that counteracts it. This way of controlling a system is called *feedforward*. Feedforward is particularly useful in shaping the response to command signals because command signals are always available. Since feedforward attempts to match two signals, it requires good process models; otherwise the corrections may have the wrong size or may be badly timed.

The ideas of feedback and feedforward are very general and appear in many different fields. In economics, feedback and feedforward are analogous to a market-based economy versus a planned economy. In business, a feedforward strategy corresponds to running a company based on extensive strategic planning, while a feedback strategy corresponds to a reactive approach. In biology, feedforward has been suggested as an essential element for motion control in humans that is tuned during training. Experience indicates that it is often advantageous to combine feedback and feedforward, and the correct balance requires insight and understanding of their respective properties which are summarized in Table 1.1.

### Positive Feedback

In most of this text, we will consider the role of *negative feedback*, in which we attempt to regulate the system by reacting to disturbances in a way that decreases the effect of those disturbances. Positive feedback plays an important role in social and biological systems, *positive feedback*, can play an important role. In a system with positive feedback, the increase in some variable or signal leads to a situation in which that quantity is further increased through its dynamics. This has a destabilizing effect and is usually accompanied by a saturation that limits the growth of the quantity. Although often considered undesirable, this behavior is used in biological (and engineering) systems to obtain a very fast response to a condition or signal. Another common use of positive feedback is the design of systems with oscillatory dynamics.

One example of the use of positive feedback is to create switching behavior, in which a system maintains a given state until some input crosses a threshold. Hysteresis is often present so that noisy inputs near the threshold do not cause the system to jitter. This type of behavior is called *bistability* and is often associated

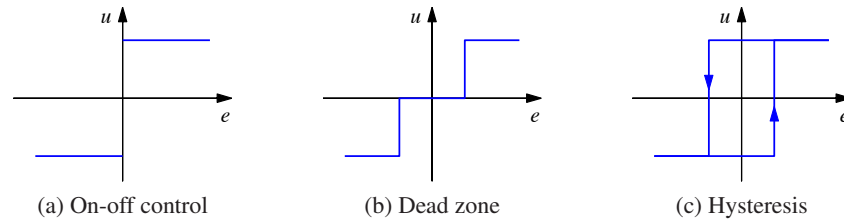

**Figure 1.13:** Input/output characteristics of on-off controllers. Each plot shows the input on the horizontal axis and the corresponding output on the vertical axis. Ideal on-off control is shown in (a), with modifications for a dead zone (b) or hysteresis (c). Note that for on-off control with hysteresis, the output depends on the value of past inputs.

with memory devices.

## 1.5 Simple Forms of Feedback

The idea of feedback to make corrective actions based on the difference between the desired and the actual values of a quantity can be implemented in many different ways. The benefits of feedback can be obtained by very simple feedback laws such as on-off control, proportional control and proportional-integral-derivative control. In this section we provide a brief preview of some of the topics that will be studied more formally in the remainder of the text.

### On-Off Control

A simple feedback mechanism can be described as follows:

$$u = \begin{cases} u_{\max} & \text{if } e > 0 \\ u_{\min} & \text{if } e < 0, \end{cases} \quad (1.1)$$

where the *control error*  $e = r - y$  is the difference between the reference signal (or command signal)  $r$  and the output of the system  $y$  and  $u$  is the actuation command. Figure 1.13a shows the relation between error and control. This control law implies that maximum corrective action is always used.

The feedback in equation (1.1) is called *on-off control*. One of its chief advantages is that it is simple and there are no parameters to choose. On-off control often succeeds in keeping the process variable close to the reference, such as the use of a simple thermostat to maintain the temperature of a room. It typically results in a system where the controlled variables oscillate, which is often acceptable if the oscillation is sufficiently small.

Notice that in equation (1.1) the control variable is not defined when the error is zero. It is common to make modifications by introducing either a dead zone or hysteresis (see Figure 1.13b and 1.13c).

### PID Control

The reason why on-off control often gives rise to oscillations is that the system overreacts since a small change in the error makes the actuated variable change over the full range. This effect is avoided in *proportional control*, where the characteristic of the controller is proportional to the control error for small errors. This can be achieved with the control law

$$u = \begin{cases} u_{\max} & \text{if } e \geq e_{\max} \\ k_p e & \text{if } e_{\min} < e < e_{\max} \\ u_{\min} & \text{if } e \leq e_{\min}, \end{cases} \quad (1.2)$$

where  $k_p$  is the controller gain,  $e_{\min} = u_{\min}/k_p$  and  $e_{\max} = u_{\max}/k_p$ . The interval  $(e_{\min}, e_{\max})$  is called the *proportional band* because the behavior of the controller is linear when the error is in this interval:

$$u = k_p(r - y) = k_p e \quad \text{if } e_{\min} \leq e \leq e_{\max}. \quad (1.3)$$

While a vast improvement over on-off control, proportional control has the drawback that the process variable often deviates from its reference value. In particular, if some level of control signal is required for the system to maintain a desired value, then we must have  $e \neq 0$  in order to generate the requisite input.

This can be avoided by making the control action proportional to the integral of the error:

$$u(t) = k_i \int_0^t e(\tau) d\tau. \quad (1.4)$$

This control form is called *integral control*, and  $k_i$  is the integral gain. It can be shown through simple arguments that a controller with integral action has zero steady-state error (Exercise 1.5). The catch is that there may not always be a steady state because the system may be oscillating. In addition, if the control action has magnitude limits, as in equation (1.2), an effect known as “integrator windup” can occur and may result in poor performance unless appropriate “anti-windup” compensation is used. Despite the potential drawbacks, which can be overcome with careful analysis and design, the benefits of integral feedback in providing zero error in the presence of constant disturbances have made it one of the most used forms of feedback.

An additional refinement is to provide the controller with an anticipative ability by using a prediction of the error. A simple prediction is given by the linear extrapolation

$$e(t + T_d) \approx e(t) + T_d \frac{de(t)}{dt},$$

which predicts the error  $T_d$  time units ahead. Combining proportional, integral and derivative control, we obtain a controller that can be expressed mathematically as

$$u(t) = k_p e(t) + k_i \int_0^t e(\tau) d\tau + k_d \frac{de(t)}{dt}. \quad (1.5)$$

The control action is thus a sum of three terms: the past as represented by the

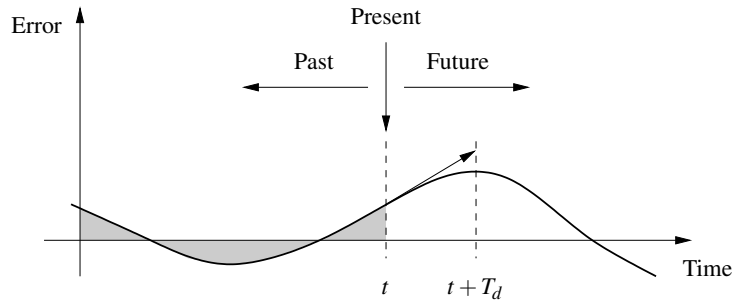

**Figure 1.14:** Action of a PID controller. At time  $t$ , the proportional term depends on the instantaneous value of the error. The integral portion of the feedback is based on the integral of the error up to time  $t$  (shaded portion). The derivative term provides an estimate of the growth or decay of the error over time by looking at the rate of change of the error.  $T_d$  represents the approximate amount of time in which the error is projected forward (see text).

integral of the error, the present as represented by the proportional term and the future as represented by a linear extrapolation of the error (the derivative term). This form of feedback is called a *proportional-integral-derivative (PID) controller* and its action is illustrated in Figure 1.14.

A PID controller is very useful and is capable of solving a wide range of control problems. More than 95% of all industrial control problems are solved by PID control, although many of these controllers are actually *proportional-integral (PI) controllers* because derivative action is often not included [DM02]. There are also more advanced controllers, which differ from PID controllers by using more sophisticated methods for prediction.

## 1.6 Combining Feedback with Logic

The PID controller is a continuous time system. The on-off controller can be viewed both as a controller and a logic system. Continuous control is often combined with logic to cope with different operating conditions. Logic is typically related to changes in operating conditions, equipment protection, manual interaction and saturating actuators. One situation is when there is one variable that is of primary interest, but other variables may have to be controlled for equipment protection. For example, when controlling a compressor the outflow is the primary variable but it may be necessary to switch to a different mode to avoid compressor stall, which may damage the compressor. We illustrate some ways in which, logic and feedback are combined by a few examples.

### Collision Avoidance

Path following is a primary criterion for controlling a robot or an autonomous vehicle but these systems also have a system for collision detection which will override path following if there is a risk for collision with another object. It is

thus necessary to have logic for choosing between path following and collision avoidance. Since controllers have state it is necessary to handle the controller states properly when switching between different control objectives as will be discussed further in Section 3.2.

### Server Farms

Server farms consist of a large number of computers for providing Internet services (cloud computing). Large server farms may have thousands of processors. Power consumption for driving the servers and for cooling them is a prime concern. The cost for energy can be more than 40% of the total cost for data centers, which is of the order of a million \$ per month for a large installation [EKR03]. The prime task of the server farm is to respond to a strongly varying computing demand. There are constraints given by electricity consumption and the available cooling capacity. The throughput of an individual server depends on the clock rate, which can be changed by the voltage applied to the system. Increasing the supply voltage increases the energy consumption and more cooling is required.

Control of server farms is often performed using a combination of feedback and logic. Capacity can be increased rapidly if a server is switched on simply by increasing the voltage to a server, but a server that is switched on consumes energy and requires cooling. Control of server farms is often performed by a combination of feedback and logic. To save energy it is advantageous to switch off servers that are not required, but it takes some time to switch on a new server. A control system for a server farm requires individual control of the voltage and cooling of each server and a strategy for switching servers on and off. Temperature is important. Overheating will reduce the life time of the system and may even destroy it. The cooling system is complicated because cooling air goes through the servers in series and parallel. The measured value for the cooling system is therefore the server with the highest temperature. Control of server farms is often performed with a combination of feedback and logic.

### Air-Fuel Control

Air-fuel control is an important problem for ship boilers. The control system consists of two loops for controlling air and oil flow and a supervisory controller that adjusts the air-fuel ratio. The ratio should be adjusted for optimal efficiency when the ships are on open sea but it is necessary to run the system with air excess when the ships are in the harbor, since generating black smoke will result in heavy penalties.

An elegant solution to the problem can be obtained by combining PI controllers with maximum and minimum selectors, as shown in Figure 1.15. A *selector* is a static system with several inputs and one output: a maximum selector gives an output which is the largest of the inputs, a minimum selector gives an output which is the smallest of the inputs. Consider the situation when the power demand is increased: the reference  $r$  to the air controller is selected as the commanded power



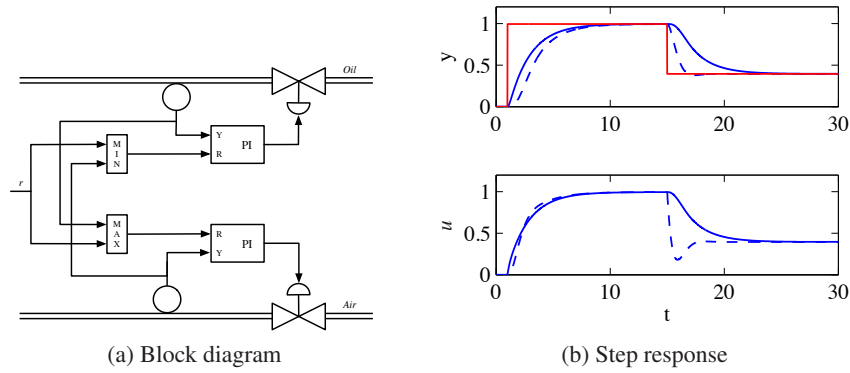

**Figure 1.15:** Air-fuel controller based on selectors. The left figure shows the system architecture. The letters  $r$  and  $y$  in the PI controller denotes the input ports for reference and measured signal respectively. The right figure shows a simulation where the power reference  $r$  (red) is changed at  $t = 1$  and  $t = 15$ . Notice that the air flow (solid blue) is larger than the fuel flow (dashed) both for increasing and decreasing reference steps.

level by the maximum selector, and the reference to the oil flow controller is selected as the measured airflow. The oil flow will lag the air flow and there will be air excess. When the commanded power level is decreased, the reference of the oil flow controller is selected as the power demand by the minimum selector and the reference for the air flow controller is selected as the oil flow by the the maximum selector. The system then operates with air excess when power is decreased.

A simulation of the control logic is shown in Figure 1.15b, based on the process model

$$\frac{dx_a}{dt} = -4x_a + 4u_a, \quad \frac{dx_o}{dt} = -x_o + u_o,$$

where  $x_a$  and  $x_o$  are the states representing air and oil dynamics. The air dynamics are faster than the oil dynamics. The PI controllers are described by

$$u_a = -k_{pa}x_a + k_{ia} \int^t (r_a - y_a) dt, \quad r_a = \max(r, x_o),$$

$$u_o = -k_{po}x_o + k_{io} \int^t (r_o - y_o) dt, \quad r_o = \min(r, x_a).$$

The controller gains used in are  $k_{pa} = 1$ ,  $k_{ia} = 1$ ,  $k_{po} = 2$  and  $k_{io} = 4$ .

Selectors are commonly used to implement logic in engines and power systems. They are also used for systems that require very high reliability: by introducing three sensors and only accepting values where two sensors agree it is possible to guard for the failure of a single sensor.

### Cruise control

The basic control function in cruise controller, such as the one shown in Figure 1.16, is to keep the velocity constant. It is typically done with a PI controller. The controller normally operates in automatic mode but it is necessary to switch

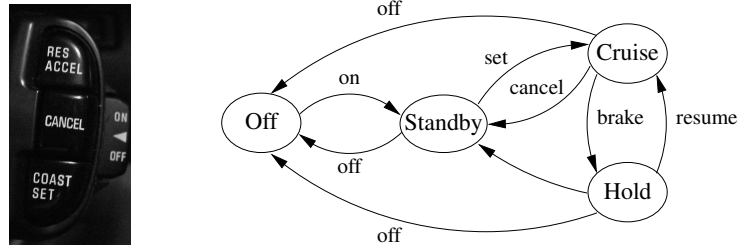

**Figure 1.16:** Finite state machine for cruise control system. The figure on the left shows some typical buttons used to control the system. The controller can be in one of four modes, corresponding to the nodes in the diagram on the right. Transition between the modes is controlled by pressing one of the five buttons on the cruise control interface: on, off, set, resume or cancel.

it off when braking, accelerating or changing gears. The cruise control system has a human-machine interface that allows the driver to communicate with the system. There are many different ways to implement this system; one version is illustrated in Figure 1.16. The system has four buttons: on-off, set/decelerate, resume/accelerate and cancel. The operation of the system is governed by a finite state machine that controls the modes of the PI controller and the reference generator; see Figure 1.16.

The finite state machine has four modes: off, standby, cruise and hold. The state changes depending on actions of the driver who can brake, accelerate and operate using the buttons. The on/off switch moves the states between off and standby. From standby the system can be moved to cruise by pushing the resume/accelerate button. The velocity reference is set as the velocity of the car when the button is released. In the cruise state the operator can change the velocity reference; it is increased by the button resume/accelerate and decreased by the button set/coast. If the driver accelerates by pushing the gas pedal the speed increases but it will go back to the set velocity when the gas pedal is released. If the driver brakes the car brakes and the cruise controller goes into hold but it remembers the set point of the controller; it can be brought to the cruise state by pushing the res/accelerate button. The system also moves from cruise mode to standby if the cancel button is pushed. The reference for the velocity controller is remembered. The system goes into off mode by pushing off.

The PI controller is designed to have good regulation properties and to give good transient performance when switching between resume and control modes.

Simple logic can be dealt with using selectors as illustrated in Section 3.2, but more formal methods are needed in more complex situation. Since controllers are dynamical systems they have a state, which has to be dealt with properly when switching controllers.

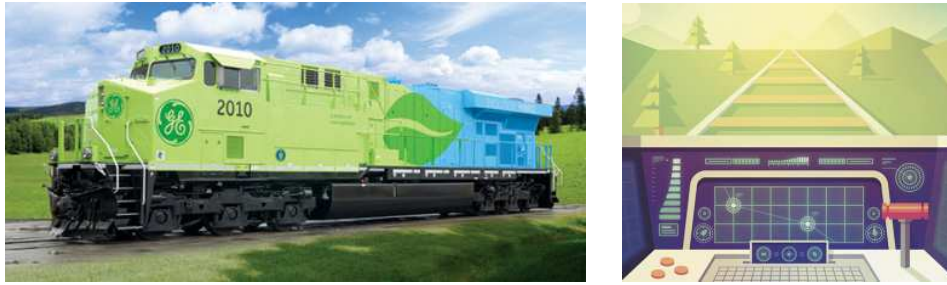

**Figure 1.17:** Freight locomotives carry massive loads of expensive diesel. GE's Trip Optimizer is a type of cruise control that combs through piles of data and synthesizes them for the driver in a way that allows him or her to steer the locomotive to maintain the most efficient speed at all times and reduce fuel burn.

## 1.7 Control System Architectures

Most of the control systems we are investigating in this book will be relatively simple feedback loops. In this section we will try to give a glimpse of the fact that in reality the simple loops combine to form a complex system which often has an hierarchical structure with controllers, logic and optimization in different combinations.

### Freight Train Trip Optimizer

Typical requirements for operating a freight train is to arrive in time and to use as little fuel as possible. The key issue is to avoid unnecessary braking. Figure 1.17 illustrates a system developed by General Electric. At the low level the train has a speed regulator and a simple logic to avoid entering a zone where there is another train. The key disturbance for the speed control is the slope of the ground. The speed controller has a model of the track, a GPS sensor and an estimator. The set point for the speed controller is obtained from a trip optimizer, computes a driving plan that minimizes the fuel consumption while arriving at the desired arrival time. The arrival time is provided by a dispatch center which in turn may use some optimization.

### Paper Factory

Figure 1.18a is a picture of a plant for making craft paper. The factory produces paper for sacks and container board from logs of wood. There are three fiber lines and six paper machines. The plant has a few dozen mechanical and chemical production processes that convert the logs to a slurry of fibers in different steps and six paper machines that convert the fiber slurry to paper. There are several dozen tanks for storage of intermediate products. Each production unit has PI(D) controllers that control, flow, temperature and tank levels. The loops typically operate in a time scales from fractions of seconds to minutes. There is logic to make sure that the process is safe and there is sequencing for start, stop and production changes.

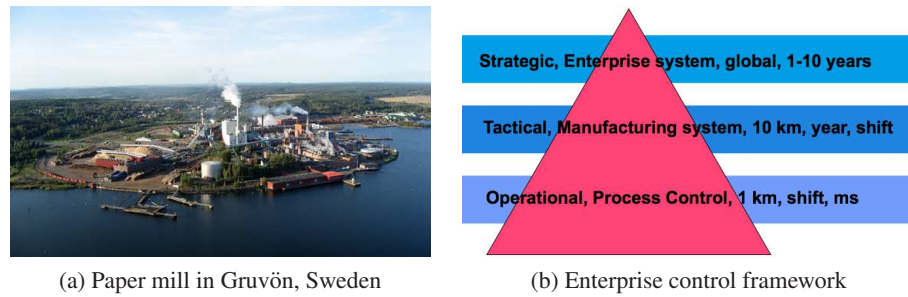

(a) Paper mill in Gruvön, Sweden

(b) Enterprise control framework

**Figure 1.18:** A paper plant with enterprise control.

Update caption

The setpoints of the low level control loops are determined from production rates and recipes, sometimes using optimization. The operation of the system is governed by a supervisory system that measures tank levels and sets the production rates of the different production unit. This system performs optimization based on demanded production, measurement of tank levels and flows. The optimization is performed at the time scale of minutes to hours and it is constrained by the production rates of the different production units. At a higher level there is a system for distributing the product and for bringing in raw material using supply chain management. The manufacturing system may also be connected to the business system at an even higher level as illustrated in Figure 1.18b. There is also extensive communication because the production unit may cover an area of kilometers and the supply chains for raw material and customers a much larger range.

Process for continuous production in the chemical and pharmaceutical industry are similar to the paper factory but the individual production units may be very different. At an abstract level the systems can be represented by Figure 1.19.

### Autonomous Driving

The cruise controller in Figure 1.10 relieves the driver of one task to keep constant speed, but a driver still has many tasks to perform: plan the route, avoid collisions, decide the proper speed, plan the route, do lane changes, make turns, keep proper distance to the car ahead. Car manufacturers are continuously automating several of these functions going as far as automatic driving. Figure 1.20 shows a block diagram of the architecture of a typical autonomous car [CEHM10]. At a high level, autonomous vehicles decompose the driving problem into four basic subsystems: sensing, perception, planning and control.

The sensing subsystem is responsible for taking raw data measurements. For the vehicle, this included GPS, IMU (inertial measurement unit) and odometry measurements (or an off the shelf system that fused these together); several teams also included vision for lane and stop line detection. For perceiving the static and dynamic urban environment, measurements included laser range finders, radar and cameras. Most teams also segmented the laser (e.g. clustering) and vision data (e.g. lane finding) in order to produce a data product of smaller size that is easier

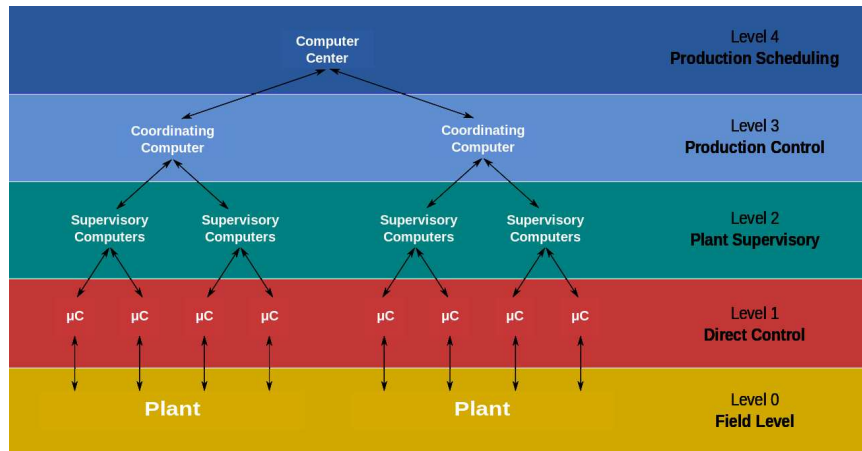

**Figure 1.19:** Functional architecture of process control system, implemented as a distributed control system (DCS). Figure provided by Daniele Pugliesi, Wikimedia Commons.

to process.

The perception subsystem is responsible for creating usable information about the vehicle and its environment. Vehicle estimation includes pose (inertial position, velocity, attitude, rates) as well as map relative information (e.g. the vehicle location within a lane or map); the latter typically uses vision or laser measurements to help to produce map relative estimates. Estimation of the environment can be accomplished in a number of ways, primarily because of the variations in sensors, computation and resources. For example, many vehicles use sensors mounted around the vehicle (front right, front left, side, etc.) and reason about elements such as the location, velocity, lane of other cars, and sensor occlusions.

The planning subsystem typically includes common components such as path planners, behavioral planners and route (map) planners. These vary, however, across different implementations. Some common approaches to path planning include graph search across a tree of possible trajectories and online optimization-based planners. Behavioral planners are usually built around finite-state machine logic. A key element in most planners is reasoning about the probabilistic information coming from the perception subsystem, which is typically accomplished with a finite-state machine. For special behaviors, such as operation at intersections, zones, and blockages, custom components are usually designed.

Finally, the control subsystem includes the actual actuators and commands to drive the car; information for the control law would come from some combination of the higher level planning (i.e. the proposed path), and/or direct sensing in some cases in order to increase the speed of response and avoid obstacles.

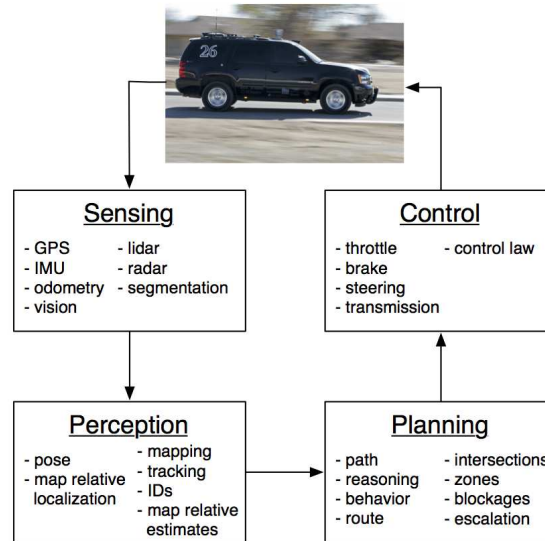

**Figure 1.20:** High level systems architecture for urban driving [CEHM10].

## 1.8 Further Reading

The material in the first half of this chapter draws heavily from the report of the Panel on Future Directions on Control, Dynamics and Systems [Mur03]. Several additional papers and reports have highlighted the successes of control [NS99] and new vistas in control [Bro00, Kum01, Wis07]. The early development of control is described by Mayr [May70] and in the books by Bennett [Ben79, Ben93], which cover the period 1800–1955. A fascinating examination of some of the early history of control in the United States has been written by Mindell [Min02]. A popular book that describes many control concepts across a wide range of disciplines is *Out of Control* by Kelly [Kel94].

There are many textbooks available that describe control systems in the context of specific disciplines. For engineers, the textbooks by Franklin, Powell and Emami-Naeini [FPEN05], Dorf and Bishop [DB04], Kuo and Golnaraghi [KG02] and Seborg, Edgar and Mellichamp [SEM04] are widely used. More mathematically oriented treatments of control theory include Sontag [Son98] and Lewis [Lew03]. The books by Hellerstein et al. [HDPT04] and Janert [Jan14] provide descriptions of the use of feedback control in computing systems. A number of books look at the role of dynamics and feedback in biological systems, including Milhorn [Mil66] (now out of print), J. D. Murray [Mur04] and Ellner and Guckenheimer [EG05]. The book by Fradkov [Fra07] and the tutorial article by Bechhoefer [Bec05] cover many specific topics of interest to the physics community.

Systems that combine continuous feedback with logic and sequencing are called hybrid systems [RST12]. The theory required to properly model and analyze such systems is outside the scope of this book. It is, however, very common that practi-

cal control systems combine feedback control with logic sequencing and selectors; many examples are given in [ÅH05].

## Exercises

**1.1** (Eye motion) Perform the following experiment and explain your results: Holding your head still, move one of your hands left and right in front of your face, following it with your eyes. Record how quickly you can move your hand before you begin to lose track of it. Now hold your hand still and shake your head left to right, once again recording how quickly you can move before losing track of your hand.

**1.2** Identify five feedback systems that you encounter in your everyday environment. For each system, identify the sensing mechanism, actuation mechanism and control law. Describe the uncertainty with respect to which the feedback system provides robustness and/or the dynamics that are changed through the use of feedback.

**1.3** (Balance systems) Balance yourself on one foot with your eyes closed for 15 s. Using Figure 1.3 as a guide, describe the control system responsible for keeping you from falling down. Note that the “controller” will differ from that in the diagram (unless you are an android reading this in the far future).

**1.4** (Cruise control) Download the MATLAB code used to produce simulations for the cruise control system in Figure 1.10 from the companion web site. Using trial and error, change the parameters of the control law so that the overshoot in speed is not more than 1 m/s for a vehicle with mass  $m = 1000$  kg.

**1.5** (Integral action) We say that a system with a constant input reaches steady state if all system variables approach constant values as time increases. Show that a controller with integral action, such as those given in equations (1.4) and (1.5), gives zero error if the closed loop system reaches steady state. Notice that there is no saturation in the controller.

**1.6** Search the web and pick an article in the popular press about a feedback and control system. Describe the feedback system using the terminology given in the article. In particular, identify the control system and describe (a) the underlying process or system being controlled, along with the (b) sensor, (c) actuator and (d) computational element. If some of the information is not available in the article, indicate this and take a guess at what might have been used.





---

## Chapter Two

### Feedback Principles

*Feedback - it is the fundamental principle that underlies all self-regulating systems, not only machines but also the processes of life and the tides of human affairs.*

A. Tustin, "Feedback", *Scientific American*, 1952 [Tus52].

This chapter presents some examples that illustrate fundamental properties of feedback: disturbance attenuation, command signal following, robustness and shaping of behavior. Simple methods for analysis and design of low order systems are introduced. After reading this chapter, readers should have some insight into the power of feedback, they should know about transfer functions and block diagrams and be able to design simple feedback systems. The basic concepts described in this chapter are explained in more detail in the remainder of the text, and this chapter can be skipped for readers who prefer to move directly to the more detailed analysis and design techniques.

#### 2.1 Mathematical Models

The fundamental properties of feedback will be illustrated using a collection of examples. We need a modest set of concepts and tools to analyze simple feedback systems: linear differential equations, transfer functions, block diagrams and block diagram algebra. In addition we need a simulation tool. In this section we will introduce some of these tools.

##### Linear Differential Equations and Transfer Functions

In many practical situations, the input/output behavior of a system can be modeled by a linear differential equation of the form

$$\frac{d^n y}{dt^n} + a_1 \frac{d^{n-1} y}{dt^{n-1}} + \cdots + a_n y = b_1 \frac{d^{n-1} u}{dt^{n-1}} + \cdots + b_n u, \quad (2.1)$$

where  $u$  is the input,  $y$  is the output and the coefficients  $a_k$  and  $b_k$  are real numbers. The model (2.1) is more general than the model given by equation (3.7) in Section 3.2 because the right hand side has terms with derivatives of the input  $u$ . The differential equation (2.1) is characterized by two polynomials

$$a(s) = s^n + a_1 s^{n-1} + \cdots + a_n, \quad b(s) = b_1 s^{n-1} + b_2 s^{n-2} + \cdots + b_n, \quad (2.2)$$

where  $a(s)$  is the *characteristic polynomial* of the differential equation (2.1).

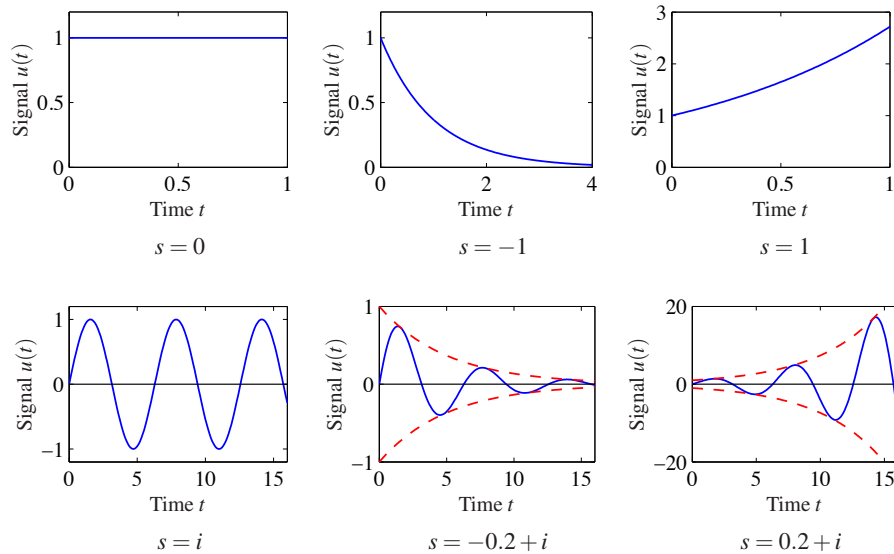

**Figure 2.1:** Examples of exponential signals. The top row corresponds to exponential signals with a real exponent, and the bottom row corresponds to those with complex exponents. The dashed line in the last two cases denotes the bounding envelope for the oscillatory signals. In each case, if the real part of the exponent is negative then the signal decays, while if the real part is positive then it grows.

The solution to equation (2.1) is the sum of two terms: the *general solution to the homogeneous equation*, which does not depend on the input, and a *particular solution*, which depends on the input. The *homogeneous equation* associated with equation (2.1) is

$$\frac{d^n y}{dt^n} + a_1 \frac{d^{n-1} y}{dt^{n-1}} + \dots + a_n y = 0. \quad (2.3)$$

Letting  $s_k$  represent the roots of the *characteristic equation*  $a(s) = 0$ , the solutions to equation (2.3) is

$$y(t) = \sum_{k=1}^n C_k e^{s_k t} \quad (2.4)$$

if the characteristic does not have multiple roots  $s_k$ . The parameters  $C_1, \dots, C_n$  are constants that can be determined from the initial conditions.

Since the coefficients  $a_k$  are real, the roots of the characteristic equation are either real-valued or occur in complex conjugate pairs. A real root  $s_k$  of the characteristic equation corresponds to the exponential function  $e^{s_k t}$ . This function decreases over time if  $s_k$  is negative, is constant if  $s_k = 0$  and increases if  $s_k$  is positive, as shown in the top row of Figure 2.1. For real roots  $s_k$  the parameter  $T = 1/s_k$  is the *time constant*.

A complex root  $s_k = \sigma \pm i\omega$  corresponds to the time functions

$$e^{\sigma t} \sin(\omega t), \quad e^{\sigma t} \cos(\omega t),$$

which have oscillatory behavior, as illustrated in the bottom row of Figure 2.1. The sine terms are shown as solid lines and the cosine terms as dashed lines; they have zero crossings with the spacing  $\pi/\omega$ . The dotted lines show the envelopes, which correspond to the exponential function  $\pm e^{\sigma t}$ .

When the characteristic equation (2.4) has multiple roots, the solutions to the homogeneous equation (2.3) take the form

$$y(t) = \sum_{k=1}^m C_k(t) e^{s_k t}, \quad (2.5)$$

where  $C_k(t)$  is a polynomial with degree less than the multiplicity of the root  $s_k$ . The solution (2.5) has  $\sum_{k=1}^m (\deg C_k + 1) = n$  free parameters.

Having explored the solution to the homogeneous equation, we now turn to the input-dependent part of the solution. The solution to equation (2.1) for an exponential input is of particular interest. We set  $u(t) = e^{st}$  and investigate if there is a unique particular solution of the form  $y(t) = G(s)e^{st}$ . Assuming this to be the case, we find

$$\begin{aligned} \frac{du}{dt} &= s e^{st}, & \frac{d^2 u}{dt^2} &= s^2 e^{st}, & \dots & \frac{d^n u}{dt^n} = s^n e^{st} \\ \frac{dy}{dt} &= s G(s) e^{st}, & \frac{d^2 y}{dt^2} &= s^2 G(s) e^{st}, & \dots & \frac{d^n y}{dt^n} = s^n G(s) e^{st}. \end{aligned} \quad (2.6)$$

Inserting these expressions into the differential equation (2.1) gives

$$(s^n + a_1 s^{n-1} + \dots + a_n) G(s) e^{st} = (b_1 s^{n-1} + b_2 s^{n-2} + \dots + b_n) e^{st}$$

and hence

$$G(s) = \frac{b_1 s^{n-1} + b_2 s^{n-2} + \dots + b_n}{s^n + a_1 s^{n-1} + \dots + a_n} = \frac{b(s)}{a(s)}. \quad (2.7)$$

This function is called the *transfer function* of the system. It describes a particular solution to the differential equation for the input  $e^{st}$ . Summarizing, we find that the solution to the differential equation (2.1) for the exponential input  $u(t) = e^{st}$  is

$$y(t) = \sum_{k=1}^m C_k(t) e^{s_k t} + G(s) e^{st}. \quad (2.8)$$

To further illustrate the relation between the transfer function and the differential equation, introduce the differential operator  $p = \frac{d}{dt}$  and the notation  $p^k = \frac{d^k}{dt^k}$ . The differential equation (2.1) can be written as

$$p^n y + a_1 p^{n-1} y + \dots + a_n y = b_1 p^{n-1} u + b_2 p^{n-2} u + \dots + b_n u,$$

or

$$(p^n + a_1 p^{n-1} + \dots + a_n) y = (b_1 p^{n-1} + b_2 p^{n-2} + \dots + b_n) u.$$

The relation between the transfer function (2.7) and the differential equation (2.1) is clear: the transfer function (2.7) can be obtained by inspection from the differential equation (2.1), and conversely the differential equation can be obtained

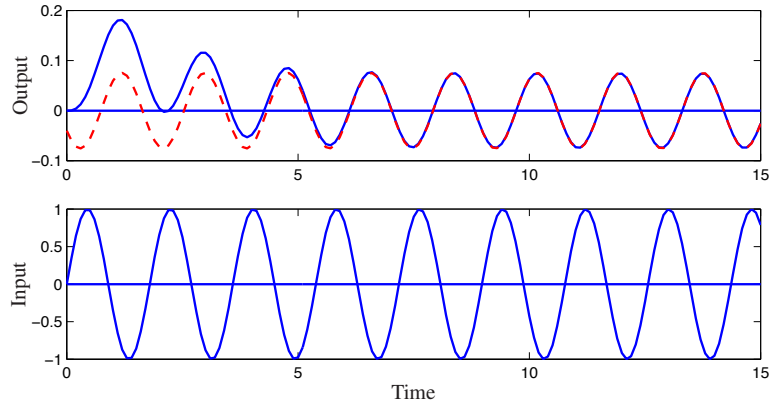

**Figure 2.2:** Two responses of a linear time-invariant system to a sinusoidal input. The dashed line shows the output when the initial conditions are chosen so that the output is purely sinusoidal. The full lines show the response for the initial conditions  $y(0) = 0$  and  $y'(0) = 0$ . The transfer function  $G(s) = 1/(s+1)^2$  and the characteristic equation has a double root  $s = -1$ .

from the transfer function. The transfer function can thus be regarded as a shorthand notation for the differential equation (2.1). It is a complete characterization of the differential equation even if it was derived as the response to a specific input  $u(t) = e^{st}$ . The input and the initial conditions must, however, be given to obtain the *solution of the differential equation* or the *response of the system*.

The transfer function  $G(s)$  is a useful representation of the differential equation (2.1) and of the system modeled by the differential equation. The particular solution for a constant input  $u(t) = 1 = e^{0 \cdot t}$  is  $y(t) = G(0) = b_n/a_n$ . The quantity  $G(0)$  is called the *zero frequency gain* or the *static gain*. To deal with oscillatory signals, like those shown in Figure 2.1, it is convenient to allow  $s$  to be a complex number. The transfer function is then a function  $G : \mathbb{C} \rightarrow \mathbb{C}$  that maps complex numbers to complex numbers. Letting  $\arg$  represent the argument (phase, angle) of a complex number and  $|\cdot|$  the magnitude, the particular solution for the input  $u = \sin(\omega t) = \text{Im} e^{i\omega t}$  is

$$\begin{aligned} y(t) &= \text{Im} (G(i\omega) e^{i\omega t}) = \text{Im} (|G(i\omega)| e^{i \arg G(i\omega)} e^{i\omega t}) \\ &= |G(i\omega)| \text{Im} e^{i(\arg G(i\omega) + \omega t)} = |G(i\omega)| \sin(\omega t + \arg G(i\omega)). \end{aligned}$$

The input is thus amplified by  $|G(i\omega)|$  and the phase shift between input and output is  $\arg G(i\omega)$ . The functions  $G(i\omega)$ ,  $|G(i\omega)|$  and  $\arg G(i\omega)$  are called the *frequency response*, *gain* and *phase*. The gain and the phase are also called *magnitude* and *angle*.

The actual response (2.8) to a sine function is the sum of a particular solution and a solution to the homogeneous equation which is determined by the initial conditions. An illustration is given in Figure 2.2. The dashed line, which is a pure

sinewave, is the solution obtained when all  $C_k$  in (2.5) are zero. The full line shows the response obtained when  $C_k$  in (2.8) are chosen so that  $y(0)$  and its derivatives  $y^{(k)}(0)$ ,  $k = 1, \dots, n - 1$  are all zero. Since all roots of the characteristic equation have negative real parts, the solution to the homogeneous equation (2.5) goes to zero as  $t \rightarrow \infty$  and the general solution converges to the particular solution as time increases.

The transfer function has many physical interpretations that can be exploited for analysis and design. The roots of the characteristic equation  $a(s) = 0$  are called *poles* of the transfer function. A pole  $s_k$  appears as exponent in the general solution to the homogeneous equation, see (2.4) or (2.5). The roots of the polynomial  $b(s)$  are called *zeros* of the transfer function. The reason is that if  $b(s_k) = 0$  it follows that  $G(s_k) = 0$ , and the particular solution for the input  $e^{s_k t}$  is then zero. A system theoretic interpretation is that the transmission of the exponential signal  $e^{s_k t}$  is blocked by the zero  $s = s_k$ . A zero is therefore also called a *transmission zero*. The transfer function makes it possible to apply algebra to determine relations between signals in a complex system. The frequency response of a stable system can be determined experimentally by exploring the response of a system to sinusoidal signals.

The transfer function can also convey a great deal of intuition: the approximations of  $G(s)$  for small and large  $s$  capture the propagation of slow and fast signals respectively. Consider for example the spring-mass system in equation (3.16), with input  $u$  (force) and output  $q$  (position), which has the transfer function

$$G(s) = \frac{1}{ms^2 + cs + k}.$$

For small  $s$  we have  $G(s) \approx 1/k$ . The corresponding input/output relation is  $q = (1/k)u$  which implies that for low frequency inputs, the system behaves like a spring driven by a force. For large  $s$  we have  $G(s) \approx 1/(ms^2)$ . The corresponding differential equation is  $m\ddot{q} = u$ , and for high frequency inputs the system behaves like mass driven by a force (a double integrator). A more elaborate treatment of transfer functions and the frequency response will be given in later chapters, particularly in Chapter 9.

### Stability: The Routh-Hurwitz Criterion

When using feedback there is always the danger that the system may become unstable, and it is therefore important to have a stability criterion. The differential equation (2.1) is called *stable* if all solutions of the homogeneous equation (2.3) go to zero for any initial condition. It follows from equation (2.5) that this requires that all the roots of the characteristic equation

$$a(s) = s^n + a_1 s^{n-1} + \dots + a_n = 0,$$

have negative real parts. The *Routh-Hurwitz criterion* is a stability criterion that does not require explicit calculation of the roots, because it gives conditions in terms of the coefficients of the characteristic polynomial.

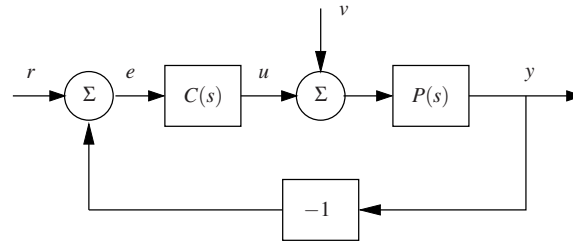

**Figure 2.3:** Block diagram of simple feedback system. The controller transfer function is  $C(s)$  and the process transfer function is  $P(s)$ . The process output is  $y$ , the external signals are the reference  $r$  and the load disturbance  $v$ .

We illustrate the Routh-Hurwitz criterion by describing it for first, second and third order differential equations. A first order differential equation is stable if the coefficient  $a_1$  of the characteristic polynomial is positive, since the zero of the characteristic polynomial will be  $s = -a_1 < 0$ . A second order polynomial is stable if and only if the coefficients  $a_1$  and  $a_2$  are all positive. Since the roots are

$$s = \frac{1}{2} \left( -a_1 \pm \sqrt{a_1^2 - 4a_2} \right),$$

it is easy to verify that the real parts are negative if and only if  $a_1 > 0$  and  $a_2 > 0$ . A third order differential equation is more complicated, but the roots can be shown to have negative real parts if and only if

$$a_1, a_2, a_3 > 0, \quad \text{and} \quad a_1 a_2 > a_3. \quad (2.9)$$

The corresponding conditions for a fourth order differential equation are

$$a_1, a_2, a_3 > 0, \quad a_1 a_2 > a_3, \quad \text{and} \quad a_1 a_2 a_3 > a_1^2 a_4 + a_3^2. \quad (2.10)$$



The Routh-Hurwitz criterion [Gan60] gives similar conditions for arbitrarily high order polynomials. Stability of a linear differential equation can thus be investigated just by analyzing the signs of various combinations of the coefficients of the characteristic polynomial.

### Block Diagrams and Transfer Functions

As described in Chapter 3, control systems are often described using block diagrams. Figure 2.3 shows a block diagram of a typical control system. The control system takes a reference signal  $r$  and compares it to the system output  $y$  (assumed to be in the same units). The resulting error is fed to a controller, whose output  $u$  drives the process. We also model process disturbances using the signal  $v$ , which we assume enters in the same location as the controller input. If each block is modeled as a linear differential equation (2.1), we need to find the differential equation that relates the signals in the complete system. A block can be considered as a filter that generates the output from the input, and the block is characterized by its transfer function, which is a nice shorthand notation for the differential equation describing the input/output relation.

Assume that the disturbance  $v$  in Figure 2.3 is zero and that we want to find the differential equation that describes how the output  $y$  is influenced by the reference signal  $r$ . Let the transfer functions of the controller and the process be characterized by the polynomials  $b_c(s)$ ,  $a_c(s)$ ,  $b_p(s)$  and  $a_p(s)$ , so that

$$C(s) = \frac{b_c(s)}{a_c(s)}, \quad P(s) = \frac{b_p(s)}{a_p(s)}. \quad (2.11)$$

The corresponding differential equations are

$$a_c(p)u(t) = b_c(p)(r(t) - y(t)), \quad a_p(p)y(t) = b_p(p)u(t),$$

where we recall that  $p^k = \frac{d^k}{dt^k}$ . Multiplying the first equation by  $a_p(p)$  and the second with  $a_c(p)$  we find that

$$a_c(p)a_p(p)y(t) = a_c(p)b_p(p)u(t) = b_p(p)b_c(p)(r(t) - y(t)).$$

Solving for  $y(t)$  gives

$$(a_c(p)a_p(p) + b_p(p)b_c(p))y(t) = b_p(p)b_c(p)r(t), \quad (2.12)$$

which is the differential equation that relates the output to the reference. We see that the polynomial notation makes it easy to manipulate differential equations. Forming linear combinations of differential equations and their derivatives corresponds to polynomial multiplication.

The differential equation (2.12) corresponds to the transfer function

$$G_{yr} = \frac{b_p(s)b_c(s)}{a_c(s)a_p(s) + b_p(s)b_c(s)} = \frac{P(s)C(s)}{1 + P(s)C(s)}, \quad (2.13)$$

where we use the notation  $G_{yr}$  for the transfer function from  $r$  to  $y$ . Proceeding in the same way we obtain the following transfer functions for other input/output pairs:

$$G_{ur} = \frac{C(s)}{1 + P(s)C(s)}, \quad G_{yv} = \frac{P(s)}{1 + P(s)C(s)}, \quad G_{uv} = \frac{-P(s)C(s)}{1 + P(s)C(s)}. \quad (2.14)$$

Instead of manipulating the differential equations we can also determine transfer functions by tracing variables around the loop. Since the transfer function can be computed from transmission of exponential signals we assume that the initial conditions for the differential equations describing the system are chosen so that all variables  $r$ ,  $e$ ,  $u$ ,  $v$  and  $y$  are exponential time functions of the form  $A(s)e^{st}$ . Assume, for example that we would like to determine the transfer function  $G_{yv}(s)$ , then let the input  $v$  be an exponential signal  $v(t) = e^{st}$ . The output is then  $y(t) = G_{yv}(s)e^{st}$ , where  $G_{yv}(s)$  is the unknown transfer function. Tracing variables around the loop in the block diagram in Figure 2.3 gives

$$y(t) = G_{yv}(s)e^{st} = P(s)e^{st} - P(s)C(s)y(t) = P(s)e^{st} - P(s)C(s)G_{yv}(s)e^{st}$$

and hence

$$G_{yv}(s)e^{st} = P(s)e^{st} - P(s)C(s)G_{yv}(s)e^{st}.$$

Solving for  $G_{yv}(s)$  gives the expression (2.14). To simplify the writing we can write the above equations as

$$y = Pv - PCy \quad \implies \quad y = \frac{P}{1 + PC}v,$$

where the lower case letters are pure exponential time functions and the capital letters are complex numbers.

By using polynomials and transfer functions the relations between signals in a feedback system can thus be obtained by algebra. In fact, the transfer functions relating two signals can be obtained from the block diagram by inspection. The denominator is always  $1 + P(s)C(s)$  and the numerator is a product of the transfer functions between the input and the output signals. For example, the transfer functions from disturbance  $v$  to control  $u$  in Figure 2.3 are  $P(s)$ ,  $-1$  and  $C(s)$  and so the numerator for  $G_{uv}$  is  $-P(s)C(s)$ .

## 2.2 Using Feedback to Improve Disturbance Attenuation

Reducing the effects of disturbances is a primary use of feedback. It was used by James Watt to make steam engines run at constant speed in spite of varying load and by electrical engineers to make generators driven by water turbines deliver electricity with constant frequency and voltage. Feedback is commonly used to alleviate disturbances in the process industry, for machine tools and for engine and cruise control in cars. In humans the pupillary reflex is used to make sure that the light intensity of the retina is reasonably constant in spite of large variations in the ambient light. The human body exploits feedback to keep body temperature, blood pressure and other important variables constant. Keeping variables close to a desired, constant reference values in spite of disturbances is called a *regulation problem*.

Disturbance attenuation will be illustrated by control of a process whose dynamics can be approximated by a first order system. A block diagram of the system is shown in Figure 2.3. Since we will focus on the effects of a load disturbance  $v$  we will assume that the reference  $r$  is zero. The transfer functions  $G_{yv}$  and  $G_{uv}$  relating the output  $y$  and the control  $u$  to the load disturbance are given by equation (2.14). For simplicity we will assume that the process is modeled by the first order differential equation

$$\frac{dy}{dt} + ay = bu, \quad a > 0, \quad b > 0.$$

The corresponding transfer function is

$$P(s) = \frac{b}{s + a}. \quad (2.15)$$

A first order system is a reasonable model of a physical system if the storage of mass, momentum or energy can be captured by a single state variable. Typical



examples are the velocity of a car on a road, the angular velocity of a rotating system and the level of a tank.

### Proportional Control

We will first investigate the case of proportional (P) control, when the control signal is proportional to the output error:  $u = k_p e$ , see Section 1.5. The controller transfer function is then  $C(s) = k_p$ . The process transfer function is given by equation (2.15) and the effect of the disturbance on the output is then described by the transfer function (2.14):

$$G_{yv}(s) = \frac{P(s)}{1 + P(s)C(s)} = \frac{\frac{b}{s+a}}{1 + \frac{bk_p}{s+a}} = \frac{b}{s+a+bk_p}.$$

The relation between the disturbance  $v$  and the output  $y$  is thus given by the differential equation

$$\frac{dy}{dt} + (a + bk_p)y = bv.$$

The closed loop system is stable if  $a + bk_p > 0$ . A constant disturbance  $v = v_0$  then gives an output that approaches the steady state value

$$y_0 = G_{yv}(0) = \frac{b}{a + bk_p} v_0$$

exponentially with the time constant  $T = 1/(a + bk_p)$ . Without feedback  $k_p = 0$  and a constant disturbance  $v_0$  thus gives the steady state error  $v_0/a$ . The steady state error thus decreases when using feedback if  $k_p > 0$ .

We have thus shown that a constant disturbance gives an error that can be reduced by feedback using a proportional controller. The error decreases with increasing controller gain. Figure 2.4a shows the responses for a few values of controller gain  $k_p$ .

### Proportional-Integral (PI) Control

The PI controller, introduced in Section 1.5, is described by

$$u(t) = k_p e(t) + k_i \int_0^t e(\tau) d\tau. \quad (2.16)$$

To determine the transfer function of the controller we differentiate, hence

$$\frac{du}{dt} = k_p \frac{de}{dt} + k_i e$$

and we find by inspection that the transfer function is  $C(s) = k_p + k_i/s$ . To investigate the effect of the disturbance  $v$  on the output we use the block diagram in Figure 2.3 and we find by inspection that the transfer function from  $v$  to  $y$  is

$$G_{yv}(s) = \frac{P(s)}{1 + P(s)C(s)} = \frac{bs}{s^2 + (a + bk_p)s + bk_i}. \quad (2.17)$$

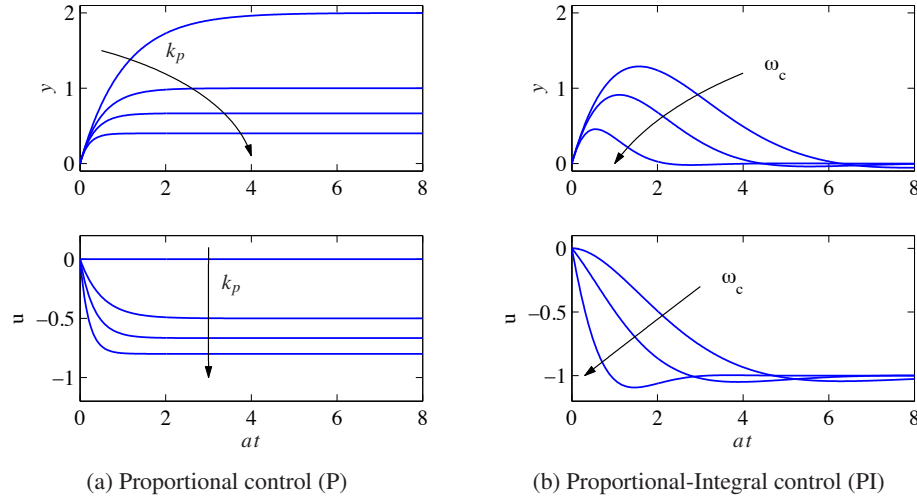

**Figure 2.4:** Responses of open and closed loop system with proportional control (a) and PI control (b). The process transfer function is  $P = 2/(s+1)$ . The controller gains for proportional control are  $k_p = 0, 0.5, 1$  and  $2$ . The PI controller is designed using equation (2.21) with  $\zeta_c = 0.707$  and  $\omega_c = 0.707, 1$  and  $2$ , which gives the controller parameters  $k_p = 0, 0.207, 0.914$  and  $k_i = 0.25, 0.50$  and  $2$ .

The relation between the load disturbance and the output is thus given by the differential equation

$$\frac{d^2y}{dt^2} + (a + bk_p)\frac{dy}{dt} + bk_i y = b\frac{dv}{dt}. \quad (2.18)$$

Notice that, since the disturbance enters as a derivative on the right hand side, a constant disturbance gives no steady state error. The same conclusion can be drawn from the observation that  $G_{yv}(0) = 0$ . Compare with the discussion of integral action and steady state error in Section 1.5.

To find suitable values of the controller parameters  $k_p$  and  $k_i$ , we consider the characteristic polynomial of the differential equation (2.18),

$$a_{cl}(s) = s^2 + (a + bk_p)s + bk_i. \quad (2.19)$$

We can assign arbitrary roots to the characteristic polynomial by choosing the controller gains  $k_p$  and  $k_i$ , and we choose controller parameters that give the characteristic polynomial

$$(s + \sigma_d + i\omega_d)(s + \sigma_d - i\omega_d) = s^2 + 2\sigma_d s + \sigma_d^2 + \omega_d^2. \quad (2.20)$$

This polynomial has roots at  $s = -\sigma_d \pm i\omega_d$ . The general solution to the homogeneous equation is then a linear combination of the terms

$$e^{-\sigma_d t} \sin(\omega_d t), \quad e^{-\sigma_d t} \cos(\omega_d t),$$

which are damped sine and cosine functions, as shown in the lower left plot in Figure 2.1. The coefficient  $\sigma_d$  determines the decay rate and the parameter  $\omega_d$

gives the frequency of the decaying oscillation. Identifying coefficients of equal powers of  $s$  in the polynomials (2.19) and (2.20) gives

$$k_p = \frac{2\sigma_d - a}{b}, \quad k_i = \frac{\sigma_d^2 + \omega_d^2}{b}. \quad (2.21)$$

Instead of parameterizing the closed loop system in terms of  $\sigma_d$  and  $\omega_d$  it is common practice to use the *undamped natural frequency*  $\omega_c = \sqrt{\sigma_d^2 + \omega_d^2}$  and the *damping ratio*  $\zeta_c = \sigma_d/\omega_c$ . The closed loop characteristic polynomial is then

$$a_{cl}(s) = s^2 + 2\sigma_d s + \sigma_d^2 + \omega_d^2 = s^2 + 2\zeta_c \omega_c s + \omega_c^2.$$

This parameterization has the advantage that  $\zeta_c$ , which is in the range  $[-1, 1]$ , determines the shape of the response and  $\omega_c$  gives the response speed.

Figure 2.4b shows the output  $y$  and the control signal  $u$  for  $\zeta_c = 1/\sqrt{2} = 0.707$  and different values of  $\omega_c$ . Proportional control gives a steady-state error which decreases with increasing controller gain  $k_p$ . With PI control the steady-state error is zero. Both the decay rate and the peak error decrease when the design parameter  $\omega_c$  is increased. Larger controller gain give smaller errors and control signals that react faster to the disturbance.

With the controller parameters (2.21) the transfer function (2.17) from disturbance  $v$  to process output becomes

$$G_{yv}(s) = \frac{P(s)}{1 + P(s)C(s)} = \frac{bs}{s^2 + 2\zeta_c \omega_c s + \omega_c^2}.$$

For efficient attenuation of disturbances is desirable that  $|G_{yv}(i\omega)|$  is small for all  $\omega$ . For small values of  $\omega$  we have  $|G_{yv}(i\omega)| \approx b\omega/\omega_c$ , for large  $\omega$  we have  $|G_{yv}(i\omega)| \approx b/\omega$ . The largest value of  $|G_{yv}(i\omega)|$  is  $b/(2\zeta_c \omega_c)$  for  $\omega = \omega_c$ . It thus follows that a large value of  $\omega_c$  gives good load disturbance attenuation.

In summary, we find that the analysis gives a simple way to find the parameters of PI controllers for processes whose dynamics can be approximated by a first order system. The technique can be generalized to more complicated systems but the controller will be more complex. To achieve the benefits of large control gains the model must be accurate over wide frequency ranges, as will be discussed next.

### Unmodeled Dynamics

The analysis we have made so far indicates that there are no limits to the performance that can be achieved. Figure 2.4b shows that arbitrarily fast response can be obtained simply by making  $\omega_c$  sufficiently large. In reality there are of course limitations on what is achievable. One reason is that the controller gains increase with  $\omega_c$ , the proportional gain is  $k_p = (2\zeta_c \omega_c - a)/b$  and the integral gain is  $k_i = \omega_c^2/b$ . A large value of  $\omega_c$  thus gives large controller gains and the control signal may be so large that actuator saturates. Another reason is that the model (2.15) is a

simplification: it is only valid in a given frequency range. If the model is instead

$$P(s) = \frac{b}{(s+a)(1+sT)}, \quad (2.22)$$

where the term  $1+sT$  represents the dynamics of sensors, actuators or other dynamics that was neglected when deriving equation (2.15), so-called *unmodeled dynamics*, the closed loop characteristic polynomial for the closed loop system becomes

$$a_{cl} = s(s+a)(1+sT) + k_p s + k_i = s^3 T + s^2(1+aT) + 2\zeta_c \omega_c s + \omega_c^2.$$

It follows from the Routh-Hurwitz criterion (2.9) that the closed loop system is stable if  $\omega_c^2 T < 2\zeta_c \omega_c(1+aT)$  or if

$$\omega_c < \frac{2\zeta_c(1+aT)}{T}.$$

The frequency  $\omega_c$  and the achievable response time are thus limited by the unmodeled dynamics represented by  $T$ . When models are developed for control it is therefore important to also consider the unmodeled dynamics.

### 2.3 Using Feedback to Follow Command Signals

Another major application of feedback is to make a system output follow a command signal. This is called the *servo problem*. Cruise control and steering of a car, tracking a satellite with an antenna or a star with a telescope are some examples. Other examples appear in high performance audio amplifiers, machine tools and industrial robots.

To illustrate command signal following we will consider the system in Figure 2.3 where the process is a first order system and the controller is a PI controller. The transfer functions of the process and the controller are

$$P(s) = \frac{b}{s+a}, \quad C(s) = \frac{k_p s + k_i}{s}. \quad (2.23)$$

Since we will focus on following the command signal  $r$  we will neglect the load disturbance,  $v = 0$ . It follows from equation (2.13) that the transfer function from the command signal  $r$  to the output  $y$  is

$$G_{yr}(s) = \frac{P(s)C(s)}{1+P(s)C(s)} = \frac{bk_p s + bk_i}{s^2 + (a+bk_p)s + bk_i}. \quad (2.24)$$

Since  $G_{yr}(0) = 1$  it follows that  $r = y$  when  $r$  and  $y$  are constant, independent of the values of the parameters  $a$  and  $b$ , as long as the closed loop is stable. The steady state output is thus equal to the reference, a useful property of controllers with integral action.

To determine suitable values of the controller parameters  $k_p$  and  $k_i$  we proceed as in Section 2.2 by choosing controller parameters that makes the closed-loop

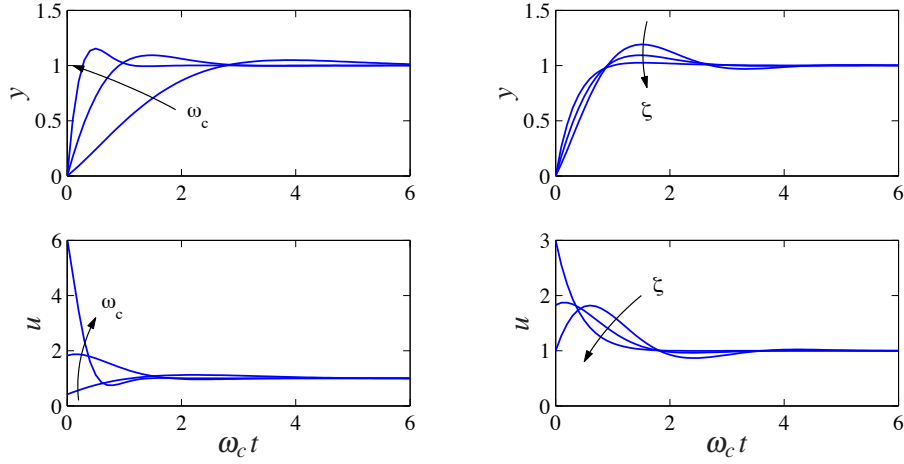

**Figure 2.5:** Responses to a unit step change in the command signal for different values of the design parameters  $\omega_c$  and  $\zeta_c$ . The left figure shows responses for fixed  $\zeta_c = 0.707$  and  $\omega_c = 1, 2$  and  $5$ . The right figure shows responses for  $\omega_c = 2$  and  $\zeta_c = 0.5, 0.707$ , and  $1$ . The process parameters are  $a = b = 1$ . The initial value of the control signal is  $k_p$ .

characteristic polynomial

$$a_{cl}(s) = s^2 + (a + bk_p)s + bk_i \quad (2.25)$$

equal to  $s^2 + 2\zeta_c\omega_c s + \omega_c^2$  with  $\zeta_c > 0$  and  $\omega_c > 0$ . Identifying coefficients of equal powers of  $s$  in these polynomials give

$$k_p = \frac{2\zeta_c\omega_c - a}{b}, \quad k_i = \frac{\omega_c^2}{b}, \quad (2.26)$$

which is equivalent to equation (2.21). Notice that integral gain increases with the square of  $\omega_c$ . Figure 2.5 shows the output signal  $y$  and the control signal  $u$  for different values of the design parameters  $\zeta_c$  and  $\omega_c$ . The response time decreases with increasing  $\omega_c$  and the initial value of the control signal also increases because it takes more effort to move rapidly. The overshoot decreases with increasing  $\zeta_c$ . For  $\omega_c = 2$ , the design choice  $\zeta_c = 1$  gives a short settling time and a response without overshoot.

It is desirable that the output  $y$  will track the reference  $r$  for time-varying references. This means that we would like the transfer function  $G_{yr}(s)$  to be close to 1 for large frequency ranges. With the controller parameters (2.26) it follows from equation (2.24) that

$$G_{yr}(s) = \frac{P(s)C(s)}{1 + P(s)C(s)} = \frac{(2\zeta_c\omega_c - a)s + \omega_c^2}{s^2 + 2\zeta_c\omega_c s + \omega_c^2}.$$

The magnitude will be close to 1 when  $\omega_c$  is large compared to  $s$ . It is thus desirable to have a large  $\omega_c$  to be able to track fast changes in the reference signal. The frequency response of  $G_{yr}$  gives a quantitative representation of the tracking

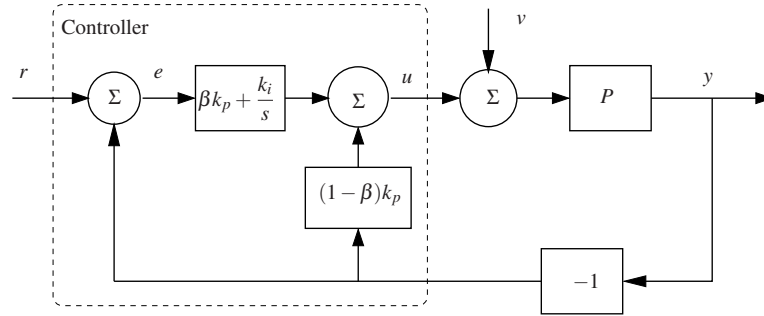

**Figure 2.6:** Block diagram of a closed-loop system with a PI controller having an architecture with two degrees of freedom.

abilities.

### Controllers with Two Degrees of Freedom

The control law in Figure 2.3 has *error feedback* because the control signal  $u$  is generated from the error  $e = r - y$ . With proportional control, a step in the reference signal  $r$  gives an immediate step change in the control signal  $u$ . This rapid reaction can be advantageous, but it may give large overshoot, which can be avoided by a replacing the PI controller in equation (2.16) with a controller of the form

$$u(t) = k_p(\beta r(t) - y(t)) + k_i \int_0^t (r(\tau) - y(\tau)) d\tau. \quad (2.27)$$

In this modified PI algorithm, the proportional action only acts on the fraction  $\beta$  of the reference signal. The signal transmission from reference  $r$  to  $u$  and from output  $y$  to  $u$  can be represented by the transfer functions

$$C_{ur}(s) = \beta k_p + \frac{k_i}{s}, \quad C_{uy}(s) = k_p + \frac{k_i}{s} = C(s). \quad (2.28)$$

The controller (2.27) is called a controller with *two degrees of freedom* since the transfer functions  $C_{ur}(s)$  and  $C_{uy}(s)$  are different.

A block diagram of a closed loop system with a PI controller having two degrees of freedom is shown in Figure 2.6. Let the process transfer function be  $P(s) = b/(s + a)$ . The transfer functions from reference  $r$  and disturbance  $v$  to output  $y$  are

$$G_{yr}(s) = \frac{b\beta k_p s + bk_i}{s^2 + (a + bk_p)s + bk_i}, \quad G_{yv}(s) = \frac{s}{s^2 + (a + bk_p)s + bk_i}. \quad (2.29)$$

Comparing with the corresponding transfer function for a controller with error feedback in equations (2.17) and (2.24) we find that the responses to the load disturbances are the same but the response to reference values are different.

A simulation of the closed loop system for  $a = 0$  and  $b = 1$  is shown in Figure 2.7. The figure shows that the parameter  $\beta$  has a significant effect on the responses. Comparing the system with error feedback ( $\beta = 1$ ) to the system with

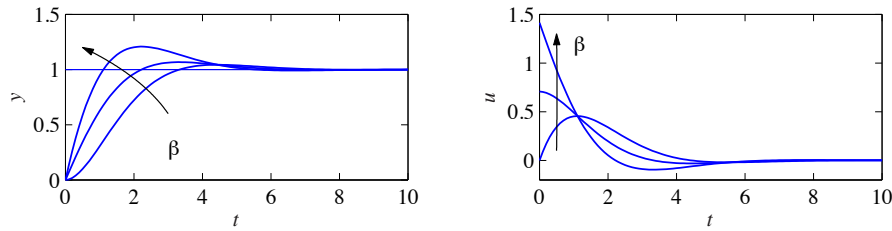

**Figure 2.7:** Response to a step change in the command signal for a system with a PI controller having two degrees of freedom. The process transfer function is  $P(s) = 1/s$  and the controller gains are  $k_p = 1.414$ ,  $k_i = 1$  and  $\beta = 0, 0.5$  and  $1$ .

smaller values of  $\beta$  we find that using a system with two degrees of freedom gives the same settling time with less overshoot and gentler control actions.

The example shows that command signal response can be improved by using a controller architecture having two degrees of freedom. In Section 2.7 we will show that the responses to command signals and disturbances can be completely separated by using a more general system architecture. To use a system with two degrees of freedom both the reference signal  $r$  and the output signal  $y$  must be measured. There are situations where only the error signal  $e = r - y$  can be measured, typical examples are DVD players, optical memories and atomic force microscopes.

## 2.4 Using Feedback to Provide Robustness

Feedback can be used to make good systems from poor components. The development of the electric feedback amplifier for transmission of telephone signals is an early example [Ben93]. Design of amplifiers with constant linear gain was a major problem. The basic component in the amplifier was the vacuum tube, which was nonlinear and time varying. A major accomplishment was the invention of the feedback amplifier. The idea is to close a feedback loop by arranging a feedback loop around the vacuum tube, which gives a closed loop system with a linear input/output relation having constant gain.

The idea to use feedback to linearize input/output characteristics and to make it insensitive to process variations is common. The recipe is to localize the source of the variations and to close feedback loops around them. This idea is used extensively to obtain linear amplifiers and actuators, and to reduce effects of friction in mechanical systems. We will illustrate with a simple model of an electronic amplifier.

### A Nonlinear Amplifier

Consider an amplifier with a static, nonlinear input/output relation with considerable variability as illustrated in Figure 2.8a. The nominal input/output characteristics is shown as a dashed bold line and examples of variations as thin lines. The



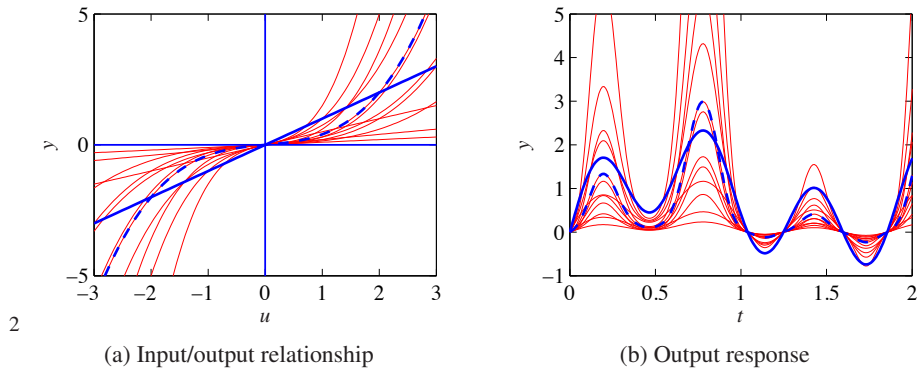

**Figure 2.8:** Responses of a static nonlinear system. The left figure shows the input/output relation of the open-loop system and the right figure shows responses to the input signal (2.31). The ideal response is shown solid bold lines. The nominal response of the nonlinear system is shown using dashed bold lines and the responses for different parameter values are shown using thin lines.

nonlinearity in the figure is actually

$$y = f(u) = \alpha(u + \beta u^3), \quad -3 \leq u \leq 3. \quad (2.30)$$

The nominal values corresponding to the dashed line are  $\alpha = 0.2$  and  $\beta = 1$ . The variations of the parameters  $\alpha$  and  $\beta$  are in the ranges  $0.1 \leq \alpha \leq 0.5$ ,  $0 \leq \beta \leq 2$ . The responses of the system to the input  $u = r$  with

$$r(t) = \sin(t) + \sin(\pi t) + \sin(\pi^2 t). \quad (2.31)$$

are shown in Figure 2.8b. The desired response  $y = u$  is shown as a solid bold line and responses for a range of parameters are shown with thin lines. The nominal response of the nonlinear system is shown as a dashed bold line. It is distorted due to the nonlinearity. Notice in particular the heavy distortion both for small and large signal amplitudes. The behavior of the system is clearly not satisfactory.

The behavior of the system can be improved significantly by introducing feedback. A block diagram of a system with a simple integral controller is shown in Figure 2.9. Figure 2.10 shows the behavior of the closed loop system with the same parameter variations as in Figure 2.8. The input/output plot in Figure 2.10a is a scatter plot of the inputs and the outputs of the feedback system. The input/output

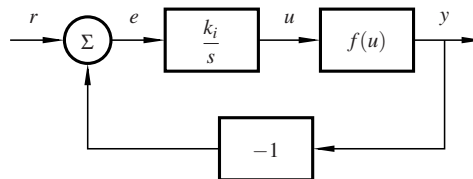

**Figure 2.9:** Block diagram of a nonlinear system with integral feedback.



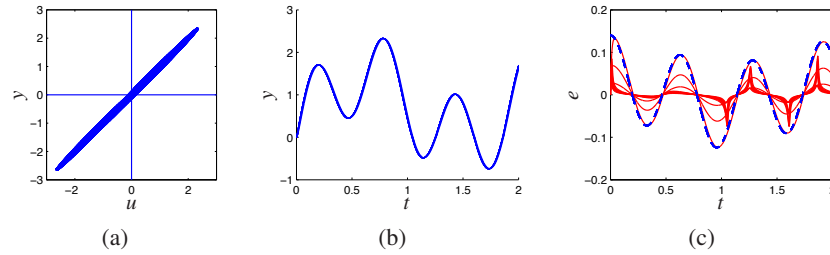

**Figure 2.10:** Responses of the system with integral feedback ( $k_i = 1000$ ). The left plot, is a scatter plot of inputs and outputs. The center plot shows the response of the closed loop system to the input signal  $r$ , and the right plot shows the control error. The parameter variations are the same as in Figure 2.8. Notice the dramatic improvement compared to Figure 2.8b. The dashed line in (c) corresponds to the approximate error based on linearization of the nonlinearity.

relation is practically linear and close to the desired response. There is some variability because of the dynamics introduced by the feedback. Figure 2.10b shows the responses to the reference signal; notice the dramatic improvement compared with Figure 2.8b. The tracking error is shown in Figure 2.10c.

### Analysis



Analysis of the closed loop system is difficult because it is nonlinear. We can however obtain significant insight by using approximations. We first observe that the system is linear when  $\beta = 0$ . In other situations we will approximate the nonlinear function by a straight line around an operating point  $u = u_0$ . The slope of the nonlinear function at  $u = u_0$  is  $f'(u_0)$  and we will approximate the process with a linear system with the gain  $f'(u_0)$ . The transfer functions of the process and the controller are

$$P(s) = b = f'(u_0) = \alpha(1 + 3\beta u_0^2), \quad C(s) = \frac{k_i}{s}, \quad (2.32)$$

where  $u_0$  denotes the operating condition. The process gain  $b = \alpha(1 + 3\beta u_0^2)$  is in the range 0.1–27.5 depending on the values of  $\alpha, \beta$  and  $u_0$ . It follows from equation (2.14) that the transfer functions relating the output  $y$  and the error  $e$  to the reference signal are

$$G_{yr}(s) = \frac{bk_i}{s + bk_i}, \quad G_{er}(s) = 1 - G_{yr} = \frac{s}{s + bk_i}. \quad (2.33)$$

The closed loop system is a first-order system with the pole  $s = -bk_i$  and the time constant  $T_{cl} = 1/(bk_i)$ . The integral gain is chosen as  $k_i = 1000$ . The closed loop pole ranges from 100 rad/s to  $2.75 \times 10^4$  rad/s, which is fast compared to the high frequency component 9.86 rad/s of the input signal.

The error for the approximated system is described by the differential equation

$$\frac{de}{dt} = -bk_i e + \frac{dr}{dt}, \quad \frac{dr}{dt} = \cos(t) + \pi \cos(\pi t) + \pi^2 \cos(\pi^2 t). \quad (2.34)$$

The fast frequency component of the input (2.31) has the frequency  $\pi^2 = 9.86$ ; it is slower than the process dynamics for all parameter variations. Neglecting the term  $de/dt$  in equation (2.34) gives

$$e \approx \frac{1}{bk_i} \frac{dr}{dt}. \quad (2.35)$$

The largest error is obtained when  $b$  has its smallest value 0.1. The error is then approximately  $\pi^2/(bk_i) \cos(\pi^2 t) \approx 0.1 \cos(\pi^2 t)$ , which is shown as the dashed line in Figure 2.10c.

This analysis has shown that it is possible to design an integrating controller for a system whose dynamics can be approximated by a static model. Design is essentially the choice of a single parameter: the integral gain  $k_i$  of the controller. The closed loop transfer function from reference to output is given by equation (2.33) where integral gain is  $k_i = 1/(bT_{cl})$  where  $T_{cl}$  is the desired time constant of the closed loop system. The integral gain is inversely proportional to  $T_{cl}$  and the largest integral gain is limited by unmodeled dynamics.

This example illustrates that feedback can be used to design an amplifier that has practically linear input/output relation even if the basic amplifier is nonlinear with strongly varying characteristics.

## 2.5 Positive Feedback

Most of this book is focused on negative feedback because of its amazingly good properties, which have been illustrated in the previous sections. In this section we will discuss positive feedback, which has complementary properties. In spite of this positive feedback has found good use in several contexts.

Systems with negative feedback can be well understood by linear analysis. To understand systems with positive feedback it is necessary to consider nonlinear effects, because without the nonlinearities the instability caused by positive feedback will grow without bounds. The nonlinear elements contribute to create interesting and useful effects by limiting the signals.

Positive feedback is common: encouraging a student or a coworker when they have performed well encourages them to do even better. In biology, it is standard to distinguish inhibitory connections (negative feedback) from excitatory feedback (positive feedback) as illustrated in Figure 2.11. Neurons use a combination of positive and negative feedback to generate spikes.

Positive feedback may cause instabilities. Exponential growth is a typical example of positive feedback, where the rate of change of a quantity  $x$  is proportional to the  $x$ . Hence

$$\frac{dx}{dt} = \alpha x,$$

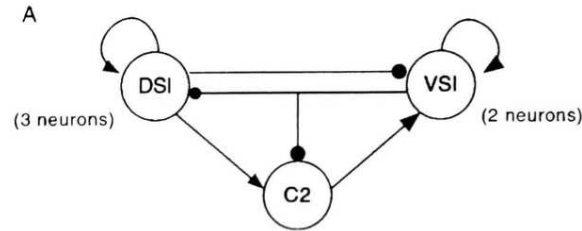

**Figure 2.11:** Schematic diagram of the neural network that controls swimming motions in the marine mollusk *Tritonia*, which has both positive and negative feedback [Wil99]. An excitatory connection (positive feedback) is denoted with a line ending with an arrow, an inhibitory interaction (negative feedback) is denoted with an arrow ending with a circle. (Figure adapted from [Wil99].)

which implies that  $x(t) = e^{\alpha t}$  grows exponentially. In nature, exponential growth of a species is limited by the finite amount of food. Another common example is when a microphone is placed close to a speaker in public address systems, resulting in a howling noise. Positive feedback can create stampedes in cattle heard, runs on banks and boom-bust behavior. In all these cases there is exponential growth that is finally limited by finite resources.

The notions of positive and negative feedback are highly intuitive but they are also too simplistic. Their interpretation is clear when we are not considering dynamics. But if dynamics is considered the sign of the feedback will depend on the frequency, and feedback can change from positive to negative when the frequency changes. A good understanding of the dynamic case can be obtained by tracing sinusoidal signals around the feedback loop as will be done in Section 10.2. We then obtain a more sophisticated notion that a block with feedback is positive if the input and output signals are in phase, and feedback is negative if signals are out of phase. With the simple interpretation it appears that a system with negative feedback will always be stable and that a system with positive feedback will always be unstable. None of these statements are true when dynamics are considered.

In spite of the drawbacks mentioned above, positive feedback has several useful applications. A typical example is the generation of periodic signals as illustrated by the following example.

### Hewlett's Oscillator

Since positive feedback tends to generate instability it can be used to construct oscillators. To limit the exponential growth it is necessary to introduce some nonlinearity that limits the amplitude of the oscillation. An example is given in a Figure 2.12 from William Hewlett's 1939 PhD thesis at Stanford University. Hewlett used two vacuum tubes with positive feedback and a nonlinear element in the form of a lamp to maintain constant amplitude of the oscillation. The positive feedback in the basic loop creates an oscillation. The resistance of the lamp decreases as the signal amplitude increases and the amplitude is limited. Hewlett's oscillator was the beginning of a very successful company that Hewlett founded with David

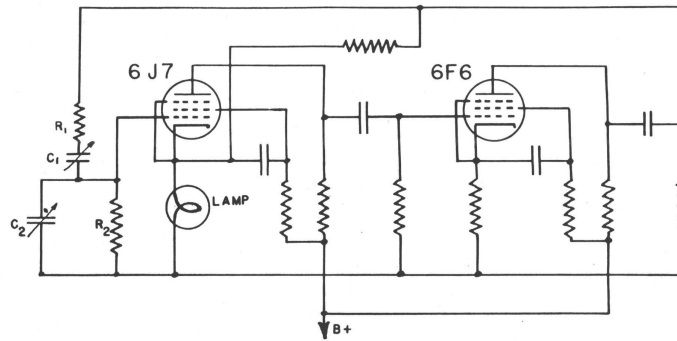

**Figure 2.12:** Circuit diagram of William Hewlett's oscillator that gives a stable oscillation by using positive feedback and a nonlinearity (lamp) that stabilized the amplitude of the oscillation, [1].

Packard.

### The Superregenerative Receiver

In the previous sections we have shown that negative feedback has some very useful properties. The negative feedback amplifier was an enabler for long-distance telephony. A key idea was to design an amplifier with a very large open loop gain and to reduce the gain by negative feedback. The result was an amplifier that is robust and linear. Positive feedback has complementary properties: it is possible to create high gain but the closed loop system is sensitive to parameter variations.

To understand that positive feedback can generate high gains we consider an amplifier with gain  $A_{ol}$ . Neglecting dynamics and closing a feedback loop around the amplifier with positive feedback  $k$  gives a closed loop system with the closed loop gain

$$A_{cl} = \frac{A_{ol}}{1 - kA_{ol}}.$$

A very large closed loop gain  $A_{cl}$  can be obtained by selecting a feedback gain  $k$  that is just below the stability limit  $1/A_{ol}$ . Choosing the gain so that  $kA_{ol} = 0.999$  gives  $A_{cl} = 1000A_{ol}$ . Using this idea, Armstrong constructed a superregenerative radio receiver in 1914 when he was still undergraduate at Columbia University. He built a radio receiver with only one vacuum tube. The drawback by using positive feedback is that the system is highly sensitive and that the gain has to be adjusted carefully to avoid oscillations. It is still used in simple walkie-talkies, garage door openers and toys.

### Implementation of Integral Action

Positive feedback was used very in early controllers where integral action was provided by positive feedback around a system with first order dynamics, as shown

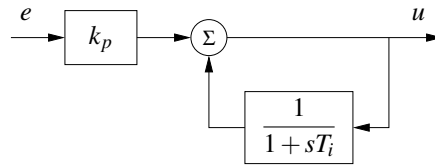

**Figure 2.13:** Implementation of integral action by *positive feedback* .

in the block diagram of Figure 2.13. Intuitively the system can be explained as follows. Proportional feedback typically gives a steady state error. This can be overcome by adding a bias signal. In Figure 2.13 the bias is estimated by low pass filtering the control signal and adding it back into to the signal path. The circuit can be understood better by a little analysis. Using block diagram algebra we find that the transfer function of the system is

$$G_{ue} = \frac{k_p}{1 - \frac{1}{1 + sT}} = k_p + \frac{k_p}{sT},$$

which is a transfer function of a PI controller. This way of implementing integral action is still used in many systems. Notice that in this case the closed loop system is in fact unstable since it has an integrator. Since this is the desired behavior (integral action), it is not necessary to limit the signal.

### Positive Feedback Combined with Saturation

Positive feedback is often combined with nonlinear elements as in Hewlett's oscillator. Figure 2.14, which shows the block diagram of a system with positive feedback and a nonlinearity in the form of a saturation is another example. The system has a forward path with a gain followed by a block with first order dynamics and a nonlinearity with saturation characteristics. We assume that the nonlinearity is given by

$$y = f(x) = \frac{x}{1 + |x|}, \quad x = f^{-1}(y) = \frac{y}{1 - |y|}. \quad (2.36)$$

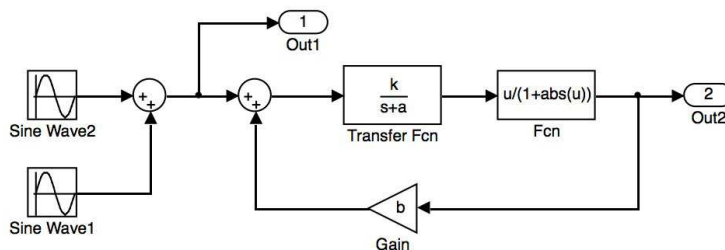

**Figure 2.14:** Block diagram of system with positive feedback and saturation. The parameters are  $a = 1$ ,  $b = 1$  and  $k = 10$ .

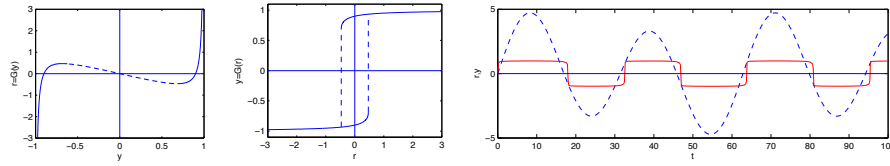

**Figure 2.15:** System with positive feedback and saturation, (a) show the function  $G(y)$  used in the analysis, (b) shows the hysteretic input output map and (c) shows a simulation of the system. The input is the dashed curve and the output is the solid line.

The system is described by the equations

$$\frac{dx}{dt} = -ax + k(r + y) = k(r - G(y)), \quad G(y) = \frac{ay}{k(1 - |y|)} - y. \quad (2.37)$$

The equilibria for a constant input  $r$  are given by

$$r = -y + \frac{a}{k} f^{-1}(y) = G(y) \quad \text{where} \quad G'(y) = -1 + \frac{a}{k(1 - |y|)^2}. \quad (2.38)$$

The graph of the function  $G$  is shown in Figure 2.14a for the parameters  $a = 1$ ,  $b = 1$  and  $k = 10$ . The function is monotone if  $k \leq a$  and there is a unique equilibrium. If  $k > a$  the function  $G$  has a maximum  $r_{max} = 1 + a/k - 2\sqrt{a/k}$  at  $y = -1/\sqrt{1 + a/k}$  and a minimum  $r_{min} = -r_{max}$  at  $y = 1/\sqrt{1 + a/k}$ . For constant  $r$  the equation (2.38) has three solutions if  $r_{min} < r < r_{max}$ , and one equilibrium if  $r < r_{min}$  or if  $r > r_{max}$ . It is easy to understand the behavior of the solutions to differential equation (2.38), since it is of first order. Since  $x$  is a monotone function of  $y$  it follows from equation (2.37) that  $dx/dt$  is positive to the left of an equilibrium where  $G'(y)$  is positive, and positive to the left of the equilibrium. The stable equilibria thus corresponds the values of  $y$  where the slope of  $G(y)$  is positive, they are marked with full lines in Figure 2.15a. The differential equation thus has two stable equilibria when  $r_{min} < r < r_{max}$  and one stable equilibrium when  $|r| > r_{max}$ . The input-output relation of the system will then have the hysteretic behavior shown in Figure 2.15b where the output switches between the values close to  $\pm 1$ . Results of a simulation of the system is shown in Figure 2.15c. The shape of the output signal depends on the parameters, the values  $a = 5$ ,  $b = 1$  and  $k = 50$  were used in the figure. The parameter  $a$  influences the dynamics of the switching, the parameter  $b$  is half the hysteresis width and the parameter  $k$  influences the sharpness of the switches..

The circuit shown in the Figure 2.14 is commonly used as a trigger to detect changes in a signal (a Schmitt trigger). It is also used as a memory element in solid state memories.

## 2.6 Using Feedback to Shape Behavior

The regulation and servo problems discussed in Sections 2.2 and 2.3 are classical applications of feedback. In Section 2.4 it was shown that feedback can be used to

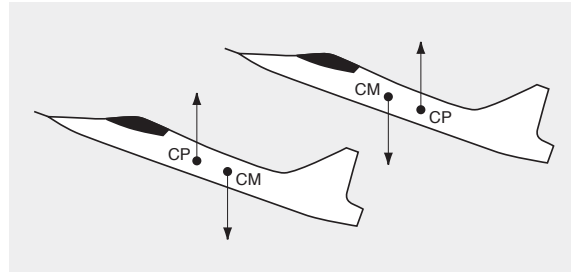

**Figure 2.16:** Schematic diagram of two aircraft. The aircraft at the top is stable because it has the center of pressure CP behind the center of mass CM. The aircraft at the bottom is unstable because the positions of center of mass and center of pressure are reversed.

obtain essentially linear input/output behavior for a nonlinear system with strong variability. In this section we will show how feedback can be used to shape the dynamic behavior of a system.

Collision avoidance is a useful behavior of moving robots. Feedback is used in automobiles to create behaviors that avoid locking brakes, skids and collision with pedestrians. Feedback is used to make the dynamic behavior of airplanes invariant to operating conditions. Feedback is also an essential element of human balancing and locomotion.

Bacteria use simple feedback mechanisms to search for areas where there is high concentration of food or light. The principle is to sense a variable and to make exploratory moves to see if the concentration increases. A similar mechanism can be used to avoid harmful substances. Optimization is also used in computer systems to maintain high throughput of servers.

### Stabilization

Stabilizing an unstable system is a typical example of how feedback can be used to change behavior. Many systems are naturally unstable. The ability to stand upright, walk and run has given humans many advantages but it requires stabilization. Stability and maneuverability are conflicting goals in vehicle design. The ship designer Minorsky realized that there was a trade-off between maneuverable and stability and he emphasized that a stable ship is difficult to steer. The Wright Flyer, which was maneuverable but unstable, inspired Sperry to design an autopilot. Feedback has been used extensively in aircraft, from simple systems for stability augmentation to systems that provide full autonomy.

Military airplanes gain significant competitive advantage by being made unstable. Schematic pictures of two airplanes are shown in Figure 2.16. The positions of the center of mass CM and the center of pressure CP are key elements. To be stable the center of pressure must be behind of the center of mass. The center of pressure of an aircraft shifts backwards when a plane goes supersonic. If the plane is stable at subsonic speeds it becomes even more stable at supersonic speeds because of the long distance between CM and CP. Large forces and large control surfaces are

then required to maneuver the airplane and the plane will be more sluggish. A more balanced design is obtained by placing the center of pressure in front of the center of mass at subsonic speeds. Such an airplane will have superior performance, but it is unstable at subsonic speeds, typically at takeoff and landing. The control system that stabilizes the aircraft in these operating conditions is mission-critical, with strong requirements on robustness and reliability.

The evolutionary biologist John Maynard Smith [Smi52] has claimed that while early flying animals were inherently stable they later developed unstable configurations when their sensory and nervous systems became more sophisticated and able to stabilize. The unstable configuration had significant advantages in manoevrability both for predator and prey.

Keeping an inverted pendulum in the upright position is a prototype example of stabilization. Consider the cart–pendulum system discussed in Examples 3.1 and 3.2. Neglecting damping, assuming that the cart is much heavier than the pendulum and assuming that the tilt angle  $\theta$  is small, equation (3.10) can be approximated by the differential equation

$$J_t \ddot{\theta} - mgl\theta = u. \quad (2.39)$$

The transfer function of the open loop system is

$$G_{\theta u} = \frac{1}{J_t s^2 - mgl}, \quad a_{cl}(s) = J_t s^2 - mgl.$$

The system is unstable because it has a pole  $s = \sqrt{mgl/J_t} = \omega_0$  in the right half plane. It can be stabilized with a *proportional-derivative (PD) controller* that has the transfer function

$$C(s) = k_d s + k_p. \quad (2.40)$$

The closed-loop characteristic polynomial is

$$a_{cl}(s) = J_t s^2 + k_d s + (k_p - mgl),$$

and all of its roots are in the left half plane if  $k_p > mgl$ .

One way to find controller parameters is to choose the controller gains so that the characteristic polynomial has natural frequency  $\omega_c$  and damping ratio  $\zeta_c$ , hence

$$k_d = 2\zeta_c \omega_c J_t, \quad k_p = J_t \omega_c^2 + mgl.$$

Choosing  $\omega_c = \omega_0$  moves the poles from  $\pm \omega_0$  in open loop to  $-\zeta_c \omega_0 \pm i\sqrt{1 - \zeta_c^2} \omega_0$  in closed loop. The controller gains are then  $k_p = 2mgl$  and  $k_d = 2\zeta_c \sqrt{mglJ_t}$ . The control law (2.40) stabilizes the pendulum but it does not stabilize the motion of the cart. To do this it is necessary to introduce feedback from cart position and cart velocity.



### The Segway

The Segway discussed in Example 3.1 is essentially a pendulum on a cart and can be modeled by equation (3.9) with an added torque  $\tau$  on the pendulum that is



exerted by the person leaning on the platform. Neglecting the damping terms  $c\dot{p}$ ,  $\gamma\dot{\theta}$  and linearizing equation (3.9) gives

$$M_t\ddot{p} - ml\ddot{\theta} = u, \quad -ml\ddot{p} + J_t\ddot{\theta} - mgl\theta = -\tau,$$

where  $u$  is the horizontal force generated by the motor and  $\tau$  is the torque generated by the lean of the rider. Since the Segway is similar to the inverted pendulum on a cart, we will explore if the feedback (2.40) can be used to stabilize the system. The closed loop system is then described by

$$M_t\ddot{p} - ml\ddot{\theta} = -k_d\dot{\theta} - k_p\theta, \quad -ml\ddot{p} + J_t\ddot{\theta} - mgl\theta = -\tau. \quad (2.41)$$

Multiplying the first equation by  $ml$ , the second by  $M_t$  and adding the equations, we obtain

$$(M_tJ_t - m^2l^2)\ddot{\theta} + mlk_d\dot{\theta} + ml(k_p - M_tg)\theta = -M_t\tau.$$

Since  $M_tJ_t - m^2l^2 = M_tJ + nMl^2 > 0$ , this differential equation is stable if  $k_p > M_tg$ . Solving for  $\ddot{p}$  in equation (2.41) gives the following transfer functions from torque  $\tau$  to tilt angle  $\theta$  and horizontal acceleration  $\ddot{p}$ :

$$G_{\ddot{p}\tau}(s) = \frac{m^2l^2s^2 - mlk_d s - mlk_p}{(M_tJ_t - m^2l^2)s^2 + mlk_d s + ml(k_p - M_tg)},$$

$$G_{\theta\tau}(s) = \frac{M_t}{(M_tJ_t - m^2l^2)s^2 + mlk_d s + ml(k_p - M_tg)}.$$

The feedback (2.40), which stabilizes the Segway, thus creates a behavior where the horizontal acceleration  $\ddot{p}$  of the Segway can be controlled by the torque  $\tau$ , which can be generated by leaning on the Segway.

### Impedance Control and Haptics

Changing behavior of a mechanical system is common in robotics and haptics. Position control is not sufficient when industrial robots are used for grinding, polishing and assembly. The robot can be brought into proximity with the workspace by position control but to carry out the operations it is desirable to shape how the force depends on the distance between the tool and the workspace. A spring-like behavior is an example. The general problem is to create a behavior specified by a given differential equation between force and motion, a procedure called *impedance control*. Similar situations occur in teleoperation in hazardous environment or in telesurgery. In this situation the workpiece is operated remotely using a joystick. It is useful for the operator to have some indication of the forces between the tool and the workpiece. This can be accomplished by generating a force on the operators joystick that mimics the force on the workpiece.

Figure 2.17 shows two haptic input devices. The systems are pen-like with levers or gimbals containing angle sensors and force actuation. By sensing position and orientation, and generating a force depending on position and velocity, it is possible to create a behavior that simulates touching real or virtual objects. Forces that simulate friction and surface structure can also be generated.



**Figure 2.17:** Haptic devices, the left figure shows the PHANTOM® and the right a system is developed by Quanser.

We illustrate the principle with a joystick having a low friction joint. Let  $J$  be the moment of inertia, and let the actuation torque and the external torque from the operator be  $T_a$  and  $T$ , respectively. The equation of motion is

$$J \frac{d^2\theta}{dt^2} = T + T_a.$$

By measuring the angle  $\theta$  and its first two derivatives we can create the feedback

$$T_a = k_p(\theta_r - \theta) - k_d \frac{d\theta}{dt} - k_a \frac{d^2\theta}{dt^2}.$$

The closed loop system is then

$$(J + k_a) \frac{d^2\theta}{dt^2} + k_d \frac{d\theta}{dt} + k_p(\theta - \theta_r) = T.$$

The feedback has thus provided virtual inertia  $J + k_a$ , virtual damping  $k_d$  and virtual spring action  $k_p$ . If no torque  $T$  is applied, the joystick will assume the orientation given by the reference signal  $\theta_r$ . If a the user applies a torque, the joystick will behave like a damped spring-mass system.

## 2.7 Feedback and Feedforward

Feedback and feedforward have complementary properties as was discussed in Section 1.4. Feedback only acts when there are deviations between the actual and the desired behavior, feedforward acts on planned behavior. Feedback and feedforward can be combined to improve response to command signals and to reduce the effect of disturbances that can be measured. In this section we will discuss design of feedforward control.

### Feedforward and System Inversion

To explore feedforward control we will first investigate command signal following. Consider the system modeled by the differential equation (2.1):

$$\frac{d^n y}{dt^n} + a_1 \frac{d^{n-1} y}{dt^{n-1}} + \dots + a_n y = b_1 \frac{d^{n-1} u}{dt^{n-1}} + \dots + b_n u.$$

Assume that we want to find a control signal  $u$  that gives the response  $y_r$ . It follows from equation (2.1) that the desired control signal satisfies

$$b_1 \frac{d^{n-1} u}{dt^{n-1}} + \dots + b_n u = \frac{d^n y_r}{dt^n} + a_1 \frac{d^{n-1} y_r}{dt^{n-1}} + \dots + a_n y_r, \quad (2.42)$$

This equation is called the *inverse* of equation (2.1) because it is obtained by exchanging inputs and outputs. If the transfer function of the original system is  $P(s)$ , the transfer function of the inverse system is simply  $P^{-1}(s)$ .

There are problems with system inversion since the inverse may require differentiations and it may be unstable. For example, if  $b_1 \neq 0$  we have  $P^{-1}(s) \approx s/b_1$  for large  $s$ , which implies that to obtain a bounded control signal we must require that the reference signal has a smooth first derivative. If  $b_1 = 0$  we must similarly require that the reference signal has a smooth second derivative.

### Difficulties with Feedforward Compensation

Let the process and the desired response have the transfer functions

$$P(s) = \frac{1}{(s+1)^2}, \quad F_m(s) = \frac{\omega_c^2}{s^2 + 2\zeta_c \omega_c s + \omega_c^2}.$$

The feedforward transfer function is then given by equation (??), hence

$$F_f(s) = P^{-1}(s)F_m(s) = \frac{\omega_c^2(s+1)^2}{s^2 + 2\zeta_c \omega_c s + \omega_c^2}. \quad (2.43)$$

Notice that  $F_f(0) = 1$  and  $F_f(\infty) = \omega_c^2$ . The initial value of the control signal for a unit step command is thus  $\omega_c^2$  and the final value is 1. Figure 2.18 shows the outputs  $y$  and the feedforward signals  $u_{ff}$  for a unit step reference signal  $r$  and different values of  $\omega_c$ . The parameter  $\omega_c$  determines the response speed and since  $F_f(\infty) = \omega_c^2$ , very large control signals are required fast responses, Achievable performance is thus limited by the size of admissible control signals.

Let the process and the desired response be characterized by the transfer functions

$$P(s) = \frac{1-s}{(s+1)^2}, \quad F_m(s) = \frac{\omega_c^2(1-s)}{s^2 + 2\zeta_c \omega_c s + \omega_c^2}.$$

Since the process has a right half plane zero at  $s = 1$  the inverse model is unstable and it follows from equation (??) that we must require that the transfer function of the desired response has the same zero. Equation (??) gives the feedforward

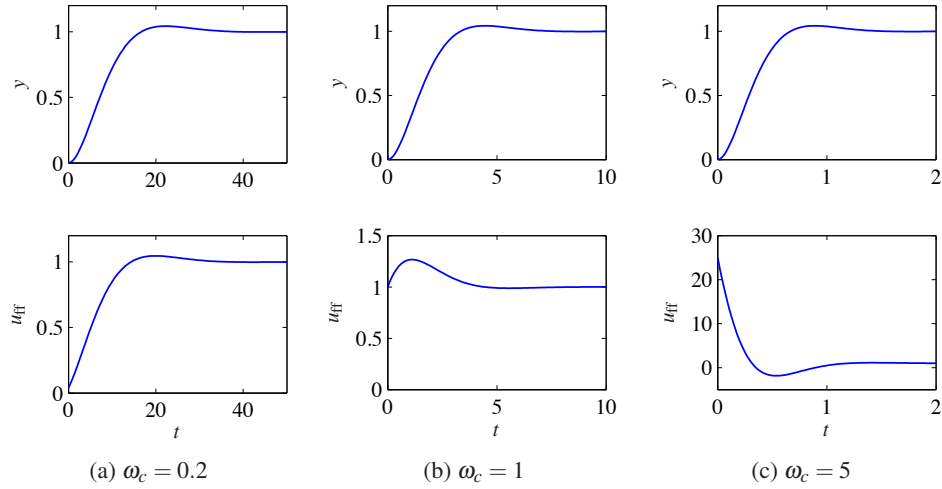

**Figure 2.18:** Outputs  $y$  (top plots) and feedforward signals  $u_{\text{ff}}$  (lower plots) for a unit step command signal. The values of the design parameter is  $\omega_c = 0.2$  (left) 1 (center) and 5 (right). The outputs are identical apart from the time scale, but the control signals required to generate the output differs significantly. The largest value of the feedforward signal  $u_{\text{ff}}$  is  $\omega_c^2$ , and it increases significantly with increasing  $\omega_c$ .

transfer function

$$F_{\text{f}}(s) = \frac{\omega_c^2(s+1)^2}{s^2 + 2\zeta_c\omega_c s + \omega_c^2}, \quad (2.44)$$

which is the same as equation (2.43). Figure 2.19 shows the outputs  $y$  and the feedforward signals  $u_{\text{ff}}$  for different values of  $\omega_c$ . The response to the command signal goes in the wrong direction initially because of the right half plane zero at  $s = 1$ . This effect, called *inverse response*, is barely noticeable if the response is slow ( $\omega_c = 1$ ) but increases with increasing response speed. For  $\omega_c = 5$  the undershoot is more than 200%. The right half plane zero thus severely limits the response time.

The behavior of the control signal changes qualitatively with  $\omega_c$ . To understand what happens we note that the zero frequency gain of the feedforward transfer function (2.44) is  $F_{\text{f}}(0) = 1$  and that its high frequency gain is  $F_{\text{f}}(\infty) = \omega_c^2$ . For a unit step reference signal  $r = 1$ , the initial value of the control signal is  $u_{\text{ff}}(0) = \omega_c^2$  and the final value is  $u_{\text{ff}}(\infty) = 1$ . For  $\omega_c = 0.2$  the control signal grows from 0.04 to the final value 1 with a small overshoot. For  $\omega_c = 1$  the control signal starts from 1 has an overshoot and settles on the final value 1. For  $\omega_c = 5$  the control signals starts at 25 and decays towards the final value 1 with an undershoot.

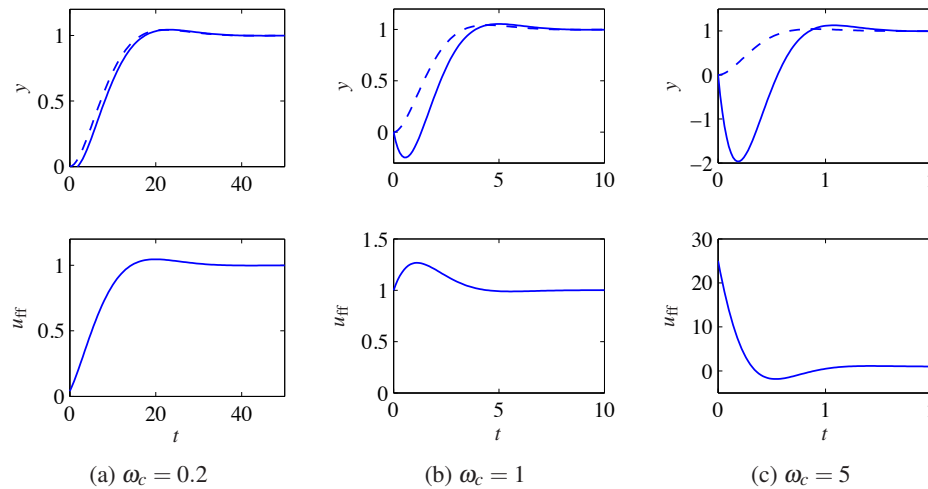

**Figure 2.19:** Outputs  $y$  (top plots) and feedforward signals  $u_{\text{ff}}$  (lower plots) for a unit step command signal. The design parameter has the values  $\omega_c = 0.2$  (left) 1 (center) and 0.5 (right) for a unit step command in the reference signal. The dashed curve shows the response that could be achieved if the process did not have the right half plane zero.

## Sensitivity to Process Variations

### Combining Feedforward with Feedback

Since feedback can give systems that are robust to model uncertainties it seems natural to combine feedforward with feedback. The architecture of such a controller is shown in the block diagram of Figure 2.20. The controller has three blocks representing the feedback transfer function  $C(s)$  and the feedforward transfer functions  $F_m$  and  $F_f$ .

The controller architecture in Figure 2.20 admits a decoupling of the response to command signals and the response to disturbances. The feedback controller  $C(s)$  is designed to give robustness to process variations and attenuation of load disturbances. The desired response to command signals is obtained by design of the feedforward transfer functions  $F_f$  and  $F_m$ .

Feedforward is most effective when the disturbance  $v$  enters early in the process. This occurs when most of the dynamics are in process section  $P_2$ . When  $P_2 = P$ , and therefore  $P_2 = 1$ , the feedforward compensator is simply a proportional controller.

Noise cancellation is a common example of the use of feedforward to cancel effects of disturbances. Consider, for example, a pilot that has to communicate in a noisy cabin. The environmental noise will seriously deteriorate the communication because the pilots microphone will pick up ambient noise. The noise can be reduced significantly by using two microphones as illustrated in Figure 2.21. The primary microphone is directed towards the pilot. It picks up the pilots voice and ambient noise. The second microphone is directed away from the pilot and it picks up the ambient noise. The effect of the noise can be reduced by filtering the

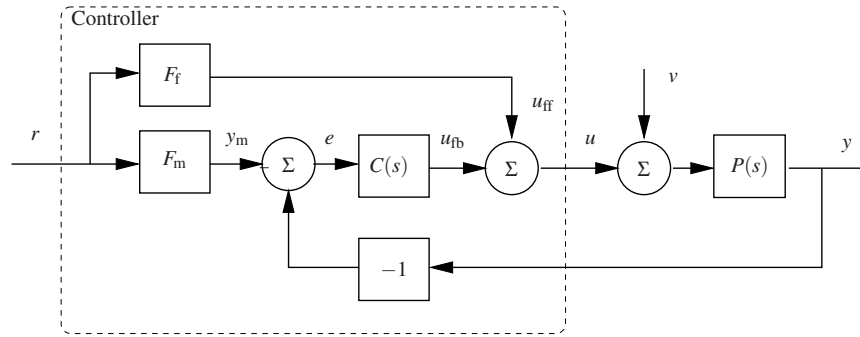
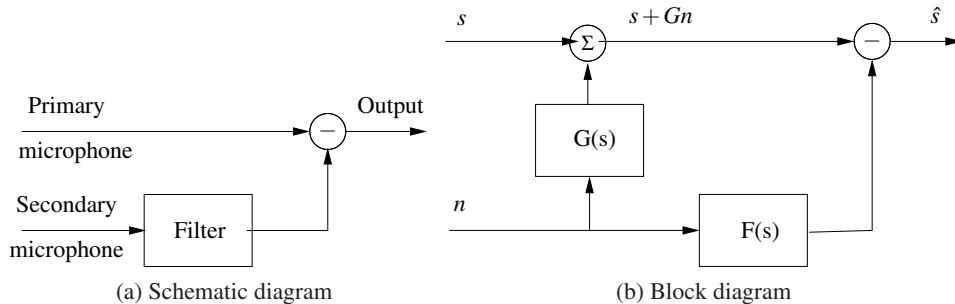

**Figure 2.20:** Block diagram of a closed loop system where the controller has an architecture with two degrees of freedom. The signals  $y_m$  and  $u_{ff}$  are generated by feedforward from the reference  $r$ . The feedback controller  $C(s)$  acts on the control error  $e = y_m - y$  and generates the feedback control signal  $u_{fb}$ .

signal from the secondary microphone and subtracting it from the signal from the primary microphone. A block diagram of the system is shown in Figure 2.21b. The transfer function  $G(s)$  represents the dynamics of the acoustic transmission from the secondary microphone to the first microphone. The transfer function  $F(s)$  is the transfer function of the filter. To cancel the effect of the noise the transfer function  $F(s)$  should be close to  $G(s)$ . Since the noise transmission depends on the situation, for example how the pilot turns his head, it is common to let the filter be adaptive so that it can adjust, as described later in Example 5.16. Noise cancellation has many applications, in headphones, to create noise-free spaces by active noise control, or to measure electrocardiograms and the heartbeats of mother and fetus.

### 2.8 Further Reading

The books by Bennett [Ben79, Ben93] and Mindel [Min02, Min08] give interesting perspective on the development of control. Much of the material touched upon in this chapter is classical control; see [CM51], [JNP47] and [Tru55]. The notion



**Figure 2.21:** Schematic and block diagrams for noise cancellation.

of controllers with two degrees of freedom was introduced by Horowitz [Hor63]. The analysis will be elaborated in the rest of the book. Transfer functions and other descriptions of dynamics are discussed in Chapters 6 and 9, methods to investigate stability in Chapter 10. The simple method to find parameters of controllers based on matching of coefficients of the closed loop characteristic polynomial is developed further in Chapters 7, 8 and 13. Feedforward control is discussed in Section 8.5 and Section 12.2.

## Exercises

**2.1** Let  $y \in \mathbb{R}$  and  $u \in \mathbb{R}$ . Solve the differential equations

$$\frac{dy}{dt} + ay = bu, \quad \frac{d^2y}{dt^2} + 2\frac{dy}{dt} + y = 2\frac{du}{dt} + u,$$

for  $t > 0$ . Determine the responses to a unit step  $u(t) = 1$  and the exponential signal  $u(t) = e^{st}$  when the initial condition is zero. Derive the transfer functions of the systems.

**2.2** Let  $y_0(t)$  be the response of a system with the transfer function  $G_0(s)$  to a given input. The transfer function  $G(s) = (1 + sT)G_0(s)$  has the same zero frequency gain but it has an additional zero at  $z = -1/T$ . Let  $y(t)$  be the response of the system with the transfer function  $G(s)$  and show that

$$y(t) = y_0(t) + T\frac{dy_0}{dt}, \quad (2.45)$$

Next consider the system with the transfer function

$$G(s) = \frac{s+a}{a(s^2+2s+1)},$$

which has unit zero-frequency-gain ( $G(0) = 1$ ). Use the result in equation (2.45) to explore the effect of the zero  $s = -1/T$  on the step response of a system

**2.3** Consider a closed loop system with process dynamics and a PI controller modeled by

$$\frac{dy}{dt} + ay = bu, \quad u = k_p(r-y) + k_i \int_0^t (r(\tau) - y(\tau))d\tau,$$

where  $r$  is the reference,  $u$  the control variable and  $y$  the process output. Derive a differential equation relating the output  $y$  to the difference by direct manipulation of the equations. Draw a block diagram of the system. Derive the transfer functions of the process and the controller. Compute the transfer function from reference  $r$  to output  $y$  of the closed loop system. Make the derivations both by direct manipulation of the system equations and by polynomial algebra. Compare the results with a direct determination of the transfer functions by inspection of the block diagram.

**2.4** The dynamics of the pupillary reflex is approximated by a linear system with the transfer function

$$P(s) = \frac{0.2(1 - 0.1s)}{(1 + 0.1s)^3}.$$

Assume that the nerve system that controls the pupil opening is modeled as a proportional controller with the gain  $k$ . Use Routh-Hurwitz theorem to determine the largest gain that gives a stable closed loop system.

**2.5** A simple model for the relation between speed  $v$  and throttle  $u$  for a car is given by the transfer function

$$G_{vu} = \frac{b}{s + a}$$

where  $b = 1 \text{ m/s}^2$  and  $a = 0.025 \text{ rad/s}$  (see Section 4.1). The control signal is normalized to the range  $0 \leq u \leq 1$ . Design a PI controller for the system that gives a closed loop system with the characteristic polynomial

$$a_{cl}(s) = s^2 + 2\zeta\omega_c s + \omega_c^2.$$

What are the consequences of choosing different values of the design parameters  $\zeta$  and  $\omega_c$ ? Use your judgment to find suitable values. Hint: Investigate maximum acceleration and maximum velocity for step changes in the velocity reference.

**2.6** Consider the feedback system in Figure 2.3. Let the disturbance  $v = 0$ ,  $P(s) = 1$  and  $C(s) = k_i/s$ . Determine the transfer function  $G_{yr}$  from reference  $r$  to output  $y$ . Also determine how much  $G_{yr}$  is changed when the process gain changes by 10%.

**2.7** The calculations in Section 2.2 can be interpreted as a design method for a PI controller for a first order system. A similar calculation can be made for PID control of the second order system. Let the transfer functions of the process and the controller be

$$P(s) = \frac{b}{s^2 + a_1s + a_2}, \quad C(s) = k_p + \frac{k_i}{s} + k_d s.$$

Show that the controller parameters

$$k_p = \frac{(1 + 2\alpha\zeta)\omega_c^2 - a_2}{b}, \quad k_i = \frac{\alpha\omega_c^3}{b}, \quad k_d = \frac{(\alpha + 2\zeta)\omega_c - a_1}{b}.$$

give a closed loop system with the characteristic polynomial

$$(s^2 + 2\zeta\omega_c s + \omega_c^2)(s + \alpha\omega_c).$$

**2.8** Consider an open loop system with the nonlinear input-output relation  $y = f(u)$ . Assume that the system is closed with the proportional controller  $u = k(r - y)$ . Show that the input-output relation of the closed loop system is

$$y + \frac{1}{k} f^{-1}(y) = r.$$



Estimate the largest deviation from ideal linear response  $y = r$ . Illustrate by plotting the input output responses for a)  $f(u) = \sqrt{u}$  and b)  $f(u) = u^2$  with  $0 \leq u \leq 1$  and  $k = 5, 10$  and  $100$ .

**2.9** Consider the system in Section 2.2 where the controller was designed to give a closed loop system characterized by  $\omega_c = 1$  and  $\zeta = 0.707$ . The transfer functions of the process and the controller are

$$P(s) = \frac{2}{s+1}, \quad C(s) = \frac{0.207s + 0.5}{s}.$$

The response of the closed loop system to step command signals has a settling time (time required to stay within 2% of the final value, see Figure 6.9) of  $4/\zeta\omega_c \approx 5.66$ . Assume that the attenuation of the load disturbances is satisfactory but that we want a closed loop system that responds five times faster to command signals without overshoot. Determine the transfer functions of a controller with the architecture in Figure 2.20 that gives a response to command signals with a first order dynamics. Simulate the system in the nominal case of a perfect model and explore the effects of modeling errors by simulation.

**2.10** Consider a queuing system modeled by

$$\frac{dx}{dt} = \lambda - \mu_{\max} \frac{x}{x+1}.$$

The model is nonlinear and the dynamics of the system changes significantly with the queuing length; see Example 3.12. Investigate the situation when a PI controller is used for admission control. The arrival intensity  $\lambda$  is then given by

$$\lambda = k_p(r - x) + k_i \int^t (r(t) - x(t)) dt.$$

The controller parameters are determined from the approximate model

$$\frac{dx}{dt} = \lambda.$$

Find controller parameters that give the closed loop characteristic polynomial  $s^2 + 2s + 1$  for the approximate model. Investigate the behavior of the control strategy for the nonlinear model by simulation for the input  $r = 5 + 4 \sin(0.1t)$ .



---

## Chapter Three

### System Modeling

*... I asked Fermi whether he was not impressed by the agreement between our calculated numbers and his measured numbers. He replied, "How many arbitrary parameters did you use for your calculations?" I thought for a moment about our cut-off procedures and said, "Four." He said, "I remember my friend Johnny von Neumann used to say, with four parameters I can fit an elephant, and with five I can make him wiggle his trunk."*

Freeman Dyson on describing the predictions of his model for meson-proton scattering to Enrico Fermi in 1953 [Dys04].

A model is a precise representation of a system's dynamics used to answer questions via analysis and simulation. The model we choose depends on the questions we wish to answer, and so there may be multiple models for a single dynamical system, with different levels of fidelity depending on the phenomena of interest. In this chapter we provide an introduction to the concept of modeling and present some basic material on two specific methods commonly used in feedback and control systems: differential equations and difference equations.

### 3.1 Modeling Concepts

A *model* is a mathematical representation of a physical, biological or information system. Models allow us to reason about a system and make predictions about how a system will behave. In this text, we will mainly be interested in models of dynamical systems describing the input/output behavior of systems, and we will often work in "state space" form. As pointed out already in Chapter 1, when using models it is important to keep in mind that they are an *approximation* of the underlying system. Analysis and design using models must always be done carefully to insure that the limits of the model are respected.

Roughly speaking, a dynamical system is one in which the effects of actions do not occur immediately. For example, the velocity of a car does not change immediately when the gas pedal is pushed nor does the temperature in a room rise instantaneously when a heater is switched on. Similarly, a headache does not vanish right after an aspirin is taken, requiring time for it to take effect. In business systems, increased funding for a development project does not increase revenues in the short term, although it may do so in the long term (if it was a good investment). All of these are examples of dynamical systems, in which the behavior of the system evolves with time.

In the remainder of this section we provide an overview of some of the key concepts in modeling. The mathematical details introduced here are explored more

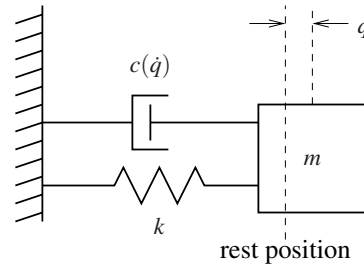

**Figure 3.1:** Spring–mass system with nonlinear damping. The position of the mass is denoted by  $q$ , with  $q = 0$  corresponding to the rest position of the spring. The forces on the mass are generated by a linear spring with spring constant  $k$  and a damper with force dependent on the velocity  $\dot{q}$ .

fully in the remainder of the chapter.

### The Heritage of Mechanics

The study of dynamics originated in attempts to describe planetary motion. The basis was detailed observations of the planets by Tycho Brahe and the results of Kepler, who found empirically that the orbits of the planets could be well described by ellipses. Newton embarked on an ambitious program to try to explain why the planets move in ellipses, and he found that the motion could be explained by his law of gravitation and the formula stating that force equals mass times acceleration. In the process he also invented calculus and differential equations.

One of the triumphs of Newton’s mechanics was the observation that the motion of the planets could be predicted based on the current positions and velocities of all planets. It was not necessary to know the past motion. The *state* of a dynamical system is a collection of variables that completely captures the past motion of a system for the purpose of predicting future motion. For a system of planets the state is simply the positions and the velocities of the planets. We call the set of all possible states the *state space*.

A common class of mathematical models for dynamical systems is ordinary differential equations (ODEs). In mechanics, one of the simplest such differential equations is that of a spring–mass system with damping:

$$m\ddot{q} + c(\dot{q}) + kq = 0. \quad (3.1)$$

This system is illustrated in Figure 3.1. The variable  $q \in \mathbb{R}$  represents the position of the mass  $m$  with respect to its rest position. We use the notation  $\dot{q}$  to denote the derivative of  $q$  with respect to time (i.e., the velocity of the mass) and  $\ddot{q}$  to represent the second derivative (acceleration). The spring is assumed to satisfy Hooke’s law, which says that the force is proportional to the displacement. The friction element (damper) is taken as a nonlinear function  $c(\dot{q})$ , which can model effects such as stiction and viscous drag. The position  $q$  and velocity  $\dot{q}$  represent the instantaneous state of the system. We say that this system is a *second-order system* since it has two states which we combine in the *state vector*  $x = (q, \dot{q})$ .

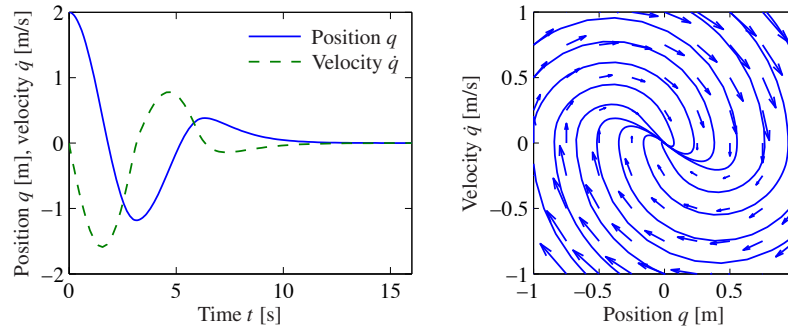

**Figure 3.2:** Illustration of a state model. A state model gives the rate of change of the state as a function of the state. The plot on the left shows the evolution of the state as a function of time. The plot on the right, called a *phase portrait*, shows the evolution of the states relative to each other, with the velocity of the state denoted by arrows.

The evolution of the position and velocity can be described using either a time plot or a phase portrait, both of which are shown in Figure 3.2. The *time plot*, on the left, shows the values of the individual states as a function of time. The *phase portrait*, on the right, shows the traces of some of the states from different initial conditions, it illustrates how the states move in the state space. In the phase portrait we have also shown arrows that represent the velocity  $\dot{x}$  of the state  $x$  in a few points. The phase portrait gives a strong intuitive representation of the equation as a vector field or a flow. While systems of second order (two states) can be represented in this way, unfortunately it is difficult to visualize equations of higher order using this approach.

The differential equation (3.1) is called an *autonomous* system because there are no external influences. (Note that this usage of “autonomous” is slightly different than in the phrase “autonomous vehicle”.) Such a model is natural for use in celestial mechanics because it is difficult to influence the motion of the planets. In many examples, it is useful to model the effects of external disturbances or controlled forces on the system. One way to capture this is to replace equation (3.1) by

$$m\ddot{q} + c(\dot{q}) + kq = u, \quad (3.2)$$

where  $u$  represents the effect of external inputs. The model (3.2) is called a *forced* or *controlled differential equation*. It implies that the rate of change of the state can be influenced by the input  $u(t)$ . Adding the input makes the model richer and allows new questions to be posed. For example, we can examine what influence external disturbances have on the trajectories of a system. Or, in the case where the input variable is something that can be modulated in a controlled way, we can analyze whether it is possible to “steer” the system from one point in the state space to another through proper choice of the input.

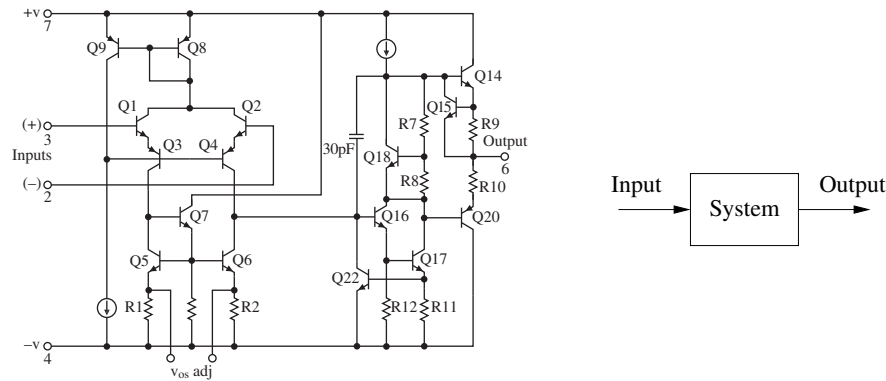

**Figure 3.3:** Illustration of the input/output view of a dynamical system. The figure on the left shows a detailed circuit diagram for an electronic amplifier; the one on the right is its representation as a block diagram.

### The Heritage of Electrical Engineering

A different view of dynamics emerged from electrical engineering, where the design of electronic amplifiers led to a focus on input/output behavior. A system was considered a device that transforms inputs to outputs, as illustrated in Figure 3.3. Conceptually an input/output model can be viewed as a giant table of inputs and outputs. Given an input signal  $u(t)$  over some interval of time, the model should produce the resulting output  $y(t)$ .

The input/output framework is used in many engineering disciplines since it allows us to decompose a system into individual components connected through their inputs and outputs. Thus, we can take a complicated system such as a radio or a television and break it down into manageable pieces such as the receiver, demodulator, amplifier and speakers. Each of these pieces has a set of inputs and outputs and, through proper design, these components can be interconnected to form the entire system.

The input/output view is particularly useful for the special class of *linear time-invariant systems*. This term will be defined more carefully later in this chapter, but roughly speaking a system is linear if the superposition (addition) of two inputs yields an output that is the sum of the outputs that would correspond to individual inputs being applied separately. A system is time-invariant if the output response for a given input does not depend on when that input is applied.

Many electrical engineering systems can be modeled by linear time-invariant systems, and hence a large number of tools have been developed to analyze them. One such tool is the *step response*, which describes the relationship between an input that changes from zero to a constant value abruptly (a step input) and the corresponding output. As we shall see later in the text, the step response is very useful in characterizing the performance of a dynamical system, and it is often used to specify the desired dynamics. A sample step response is shown in Figure 3.4a.

Another way to describe a linear time-invariant system is to represent it by its

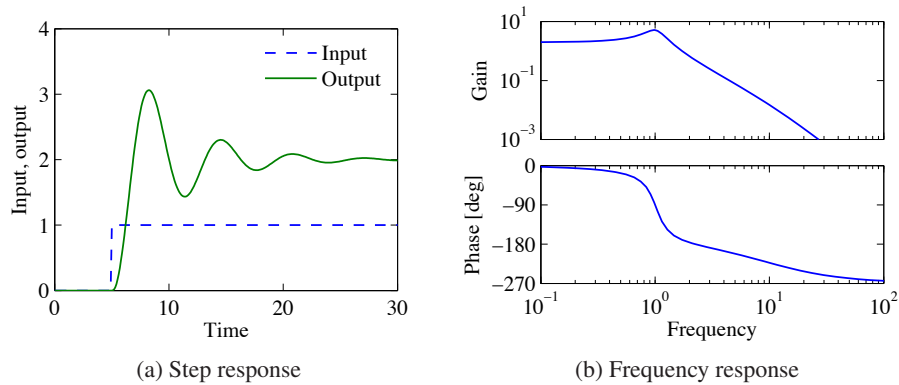

**Figure 3.4:** Input/output response of a linear system. The step response (a) shows the output of the system due to an input that changes from 0 to 1 at time  $t = 5$  s. The frequency response (b) shows the amplitude gain and phase change due to a sinusoidal input at different frequencies.

response to sinusoidal input signals. This is called the *frequency response*, and a rich, powerful theory with many concepts and strong, useful results has emerged. The results are based on the theory of complex variables and Laplace transforms. The basic idea behind frequency response is that we can completely characterize the behavior of a system by its steady-state response to sinusoidal inputs. Roughly speaking, this is done by decomposing any arbitrary signal into a linear combination of sinusoids (e.g., by using the Fourier transform) and then using linearity to compute the output by combining the response to the individual frequencies. A sample frequency response is shown in Figure 3.4b.

The input/output view lends itself naturally to experimental determination of system dynamics, where a system is characterized by recording its response to particular inputs, e.g., a step or a set of sinusoids over a range of frequencies.

### The Control View

When control theory emerged as a discipline in the 1940s, the approach to dynamics was strongly influenced by the electrical engineering (input/output) view. A second wave of developments in control, starting in the late 1950s, was inspired by mechanics, where the state space perspective was used. The emergence of space flight is a typical example, where precise control of the orbit of a spacecraft is essential. These two points of view gradually merged into what is today the state space representation of input/output systems. In the 1970s the development was influenced by advances in automation, which emphasized the need to include logic and sequencing.

The development of state space models involved modifying the models from mechanics to include external actuators and sensors and utilizing more general

forms of equations. In control, the model given by equation (3.2) was replaced by

$$\frac{dx}{dt} = f(x, u), \quad y = h(x, u), \quad (3.3)$$

where  $x$  is a vector of state variables,  $u$  is a vector of control signals and  $y$  is a vector of measurements. The term  $dx/dt$  represents the derivative of  $x$  with respect to time, now considered a vector, and  $f$  and  $h$  are (possibly nonlinear) mappings of their arguments to vectors of the appropriate dimension. For mechanical systems, the state consists of the position and velocity of the system, so that  $x = (q, \dot{q})$  in the case of a damped spring–mass system. Note that in the control formulation we model dynamics as first-order differential equations, but we will see that this can capture the dynamics of higher-order differential equations by appropriate definition of the state and the maps  $f$  and  $h$ .

Adding inputs and outputs has increased the richness of the classical problems and led to many new concepts. For example, it is natural to ask if possible states  $x$  can be reached with the proper choice of  $u$  (reachability) and if the measurement  $y$  contains enough information to reconstruct the state (observability). These topics will be addressed in greater detail in Chapters 7 and 8.

A final development in building the control point of view was the emergence of disturbances and model uncertainty as critical elements in the theory. The simple way of modeling disturbances as deterministic signals like steps and sinusoids has the drawback that such signals cannot be predicted precisely. A more realistic approach is to model disturbances as random signals. This viewpoint gives a natural connection between prediction and control. The dual views of input/output representations and state space representations are particularly useful when modeling systems with uncertainty since state models are convenient to describe a nominal model but uncertainties are easier to describe using input/output models (often via a frequency response description). Uncertainty will be a constant theme throughout the text and will be studied in particular detail in Chapter 13.

An interesting observation in the design of control systems is that feedback systems can often be analyzed and designed based on comparatively simple models. The reason for this is the inherent robustness of feedback systems. However, other uses of models may require more complexity and more accuracy. One example is feedforward control strategies, where one uses a model to precompute the inputs that cause the system to respond in a certain way. Another area is system validation, where one wishes to verify that the detailed response of the system performs as it was designed. Because of these different uses of models, it is common to use a hierarchy of models having different complexity and fidelity.



### Multidomain Modeling

Modeling is an essential element of many disciplines, but traditions and methods from individual disciplines can differ from each other, as illustrated by the previous discussion of mechanical and electrical engineering. A difficulty in systems engineering is that it is frequently necessary to deal with heterogeneous systems



from many different domains, including chemical, electrical, mechanical and information systems.

To model such multidomain systems, we start by partitioning a system into smaller subsystems. Each subsystem is represented by balance equations for mass, energy and momentum, or by appropriate descriptions of information processing in the subsystem. The behavior at the interfaces is captured by describing how the variables of the subsystem behave when the subsystems are interconnected. These interfaces act by constraining variables within the individual subsystems to be equal (such as mass, energy or momentum fluxes). The complete model is then obtained by combining the descriptions of the subsystems and the interfaces.

Using this methodology it is possible to build up libraries of subsystems that correspond to physical, chemical and informational components. The procedure mimics the engineering approach where systems are built from subsystems that are themselves built from smaller components. As experience is gained, the components and their interfaces can be standardized and collected in model libraries. In practice, it takes several iterations to obtain a good library that can be reused for many applications.

State models or ordinary differential equations are not suitable for component-based modeling of this form because states may disappear when components are connected. This implies that the internal description of a component may change when it is connected to other components. As an illustration we consider two capacitors in an electrical circuit. Each capacitor has a state corresponding to the voltage across the capacitors, but one of the states will disappear if the capacitors are connected in parallel. A similar situation happens with two rotating inertias, each of which is individually modeled using the angle of rotation and the angular velocity. Two states will disappear when the inertias are joined by a rigid shaft.

This difficulty can be avoided by replacing differential equations by *differential algebraic equations*, which have the form

$$F(z, \dot{z}) = 0,$$

where  $z \in \mathbb{R}^n$ . A simple special case is

$$\dot{x} = f(x, y), \quad g(x, y) = 0, \quad (3.4)$$

where  $z = (x, y)$  and  $F = (\dot{x} - f(x, y), g(x, y))$ . The key property is that the derivative  $\dot{z}$  is not given explicitly and there may be pure algebraic relations between the components of the vector  $z$ . Modeling using differential algebraic equations is also called *equation-based modeling*, *acausal modeling* or *behavioral modeling*.

The model (3.4) captures the examples of the parallel capacitors and the linked rotating inertias. For example, when two capacitors are connected, we simply add the algebraic equation expressing that the voltages across the capacitors are the same.

*Modelica* is a language that has been developed to support component-based modeling. Differential algebraic equations are used as the basic description, and object-oriented programming is used to structure the models. Modelica is used to

model the dynamics of technical systems in domains such as mechanical, electrical, thermal, hydraulic, thermofluid and control subsystems. Modelica is intended to serve as a standard format so that models arising in different domains can be exchanged between tools and users. A large set of free and commercial Modelica component libraries are available and are used by a growing number of people in industry, research and academia. For further information about Modelica, see <http://www.modelica.org> or Tiller [Til01].



### Finite State Machines and Hybrid Systems

A final type of modeling has been developed within the hybrid systems community. A hybrid system (also called a *cyberphysical system*) is one that combines continuous dynamics with discrete logic. The discrete portion of the system represents logical variables that reside in a computer, such as the mode of a system (on, off, degraded, etc.).

Discrete state dynamics are often represented using a *finite state machine* that consists of a finite set of discrete states  $\alpha \in \mathbb{Q}$ . We can think of  $\alpha$  as the “mode” of the system. The dynamics of a finite state machine are defined in terms of transitions between the states. One convenient representation is as a *guarded transition system*:

$$g_i(\alpha, \beta) \implies \alpha' = r_i(\alpha), \quad i = 1, \dots, N.$$

Here the function  $g$  is a Boolean (true/false) function that depends on the current system mode  $\alpha$  and an input  $\beta$ , which might represent an environmental event (button press, component failure, etc). If the guard  $g_i$  is true then the system transitions from the current state  $\alpha$  to a new state  $\alpha'$ , determined by the role (transition map)  $r_i$ . The guarded transition system can have many different rules, depending on the system state and external input.

It is also possible to combine systems that have finite states with those having discrete states, creating a *hybrid system*. For example, if a system has a continuous state  $x$  and discrete state  $\alpha$ , we might write the overall system dynamics as

$$\frac{dx}{dt} = f_\alpha(x, u, v), \quad g_i(x, \alpha, \beta) \implies \alpha' = r_i(x, \alpha), \quad i = 1, \dots, N.$$

In this representation, the continuous dynamics (with state  $x$ ) are governed by an ordinary differential equation that may depend on the system mode  $\alpha$  (indicated by the subscript in  $f_\alpha$ ). The discrete transition system is also influenced by the continuous state, so that the guards  $g_i$  and rules  $r_i$  now depend on the continuous state.

Many other representations are possible for hybrid systems, including models that allow a non-continuous change in the continuous variables when a change in the discrete state occurs (so-called *reset logic*). Computer modeling packages for hybrid systems include StateFlow (part of the MATLAB suite of tools), Modelica and Ptolemy [Pto14].

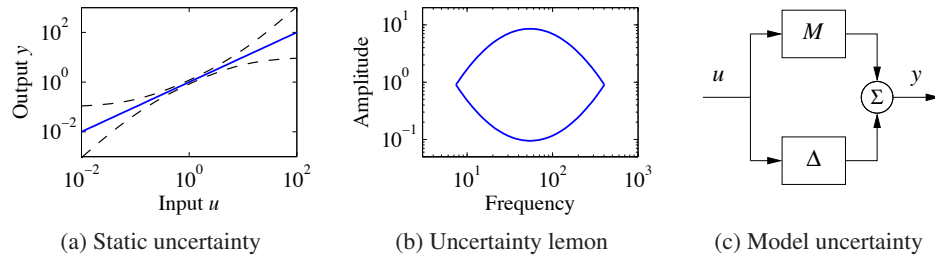

**Figure 3.5:** Characterization of model uncertainty. Uncertainty of a static system is illustrated in (a), where the solid line indicates the nominal input/output relationship and the dashed lines indicate the range of possible uncertainty. The uncertainty lemon [GPD59] in (b) is one way to capture uncertainty in dynamical systems emphasizing that a model is valid only in the amplitude and frequency ranges within the shaded region. In (c) a model is represented by a nominal model  $M$  and another model  $\Delta$  representing the uncertainty analogous to the representation of parameter uncertainty.

### Model Uncertainty

Reducing uncertainty is one of the main reasons for using feedback, and it is therefore important to characterize uncertainty. When making measurements, there is a good tradition to assign both a nominal value and a measure of uncertainty. It is useful to apply the same principle to modeling, but unfortunately it is often difficult to express the uncertainty of a model quantitatively.

For a static system whose input/output relation can be characterized by a function, uncertainty can be expressed by an uncertainty band as illustrated in Figure 3.5a. At low signal levels there are uncertainties due to sensor resolution, friction and quantization. For example, some models for queuing systems or cells are based on averages that exhibit significant variations for small populations. At large signal levels there are saturations or even system failures. The signal ranges where a model is reasonably accurate vary dramatically between applications, but it is rare to find models that are accurate for signal ranges larger than  $10^4$ .

Characterization of the uncertainty of a dynamic model is much more difficult. We can try to capture uncertainties by assigning uncertainties to parameters of the model, but this is often not sufficient. There may be errors due to phenomena that have been neglected, e.g., small time delays. In control the ultimate test is how well a control system based on the model performs, and time delays can be important. There is also a frequency aspect. There are slow phenomena, such as aging, that can cause changes or drift in the systems. There are also high-frequency effects: a resistor will no longer be a pure resistance at very high frequencies, and a beam has stiffness and will exhibit additional dynamics when subject to high-frequency excitation. The *uncertainty lemon* [GPD59] shown in Figure 3.5b is one way to conceptualize the uncertainty of a system. It illustrates that a model is valid only in certain amplitude and frequency ranges.

We will introduce some formal tools for representing uncertainty in Chapter 13

using figures such as Figure 3.5c. These tools make use of the concept of a transfer function, which describes the frequency response of an input/output system. For now, we simply note that one should always be careful to recognize the limits of a model and not to make use of models outside their range of applicability. For example, one can describe the uncertainty lemon and then check to make sure that signals remain in this region. In early analog computing, a system was simulated using operational amplifiers, and it was customary to give alarms when certain signal levels were exceeded. Similar features can be included in digital simulation.

## 3.2 State Space Models

In this section we introduce the two primary forms of models that we use in this text: differential equations and difference equations. Both make use of the notions of state, inputs, outputs and dynamics to describe the behavior of a system. We also briefly discuss modeling of finite state system and hybrid systems.

### Ordinary Differential Equations

The state of a system is a collection of variables that summarize the past of a system for the purpose of predicting the future. For a physical system the state is composed of the variables required to account for storage of mass, momentum and energy. A key issue in modeling is to decide how accurately this storage has to be represented. The state variables are gathered in a vector  $x \in \mathbb{R}^n$  called the *state vector*. The control variables are represented by another vector  $u \in \mathbb{R}^p$ , and the measured signal by the vector  $y \in \mathbb{R}^q$ . A system can then be represented by the differential equation

$$\frac{dx}{dt} = f(x, u), \quad y = h(x, u), \quad (3.5)$$

where  $f : \mathbb{R}^n \times \mathbb{R}^p \rightarrow \mathbb{R}^n$  and  $h : \mathbb{R}^n \times \mathbb{R}^p \rightarrow \mathbb{R}^q$  are smooth mappings. We call a model of this form a *state space model*.

The dimension of the state vector is called the *order* of the model. The model (3.5) is called *time-invariant* because the functions  $f$  and  $h$  do not depend explicitly on time  $t$ ; there are more general time-varying systems where the functions do depend on time. The model consists of two functions: the function  $f$  gives the rate of change of the state vector as a function of state  $x$  and control  $u$ , and the function  $h$  gives the measured values as functions of state  $x$  and control  $u$ .

A model is called a *linear* state space model (or often just a “linear system”) if the functions  $f$  and  $h$  are linear in  $x$  and  $u$ . A linear state space model can thus be represented by

$$\frac{dx}{dt} = Ax + Bu, \quad y = Cx + Du, \quad (3.6)$$

where  $A$ ,  $B$ ,  $C$  and  $D$  are constant matrices. Such a model is said to be *linear and time-invariant*, or LTI for short. (In this text we will usually omit the term time-

invariant and just say the model is linear.) The matrix  $A$  is called the *dynamics matrix*, the matrix  $B$  is called the *control matrix*, the matrix  $C$  is called the *sensor matrix* and the matrix  $D$  is called the *direct term*. Frequently models will not have a direct term, indicating that the control signal does not influence the output directly.

A different form of linear differential equations, generalizing the second-order dynamics from mechanics, is an equation of the form

$$\frac{d^n y}{dt^n} + a_1 \frac{d^{n-1} y}{dt^{n-1}} + \cdots + a_n y = u, \quad (3.7)$$

where  $t$  is the independent (time) variable,  $y(t)$  is the dependent (output) variable and  $u(t)$  is the input. The notation  $d^k y/dt^k$  is used to denote the  $k$ th derivative of  $y$  with respect to  $t$ , sometimes also written as  $y^{(k)}$ . The controlled differential equation (3.7) is said to be an  $n$ th-order model. This model can be converted into state space form by defining

$$x = \begin{pmatrix} x_1 \\ x_2 \\ \vdots \\ x_{n-1} \\ x_n \end{pmatrix} = \begin{pmatrix} d^{n-1}y/dt^{n-1} \\ d^{n-2}y/dt^{n-2} \\ \vdots \\ dy/dt \\ y \end{pmatrix},$$

and the state space equations become

$$\frac{d}{dt} \begin{pmatrix} x_1 \\ x_2 \\ \vdots \\ x_{n-1} \\ x_n \end{pmatrix} = \begin{pmatrix} -a_1 x_1 - \cdots - a_n x_n \\ x_1 \\ \vdots \\ x_{n-2} \\ x_{n-1} \end{pmatrix} + \begin{pmatrix} u \\ 0 \\ \vdots \\ 0 \\ 0 \end{pmatrix}, \quad y = x_n.$$

With the appropriate definitions of  $A$ ,  $B$ ,  $C$  and  $D$ , this equation is in linear state space form.

An even more general model is obtained by letting the output be a linear combination of the states of the model, i.e.,

$$y = b_1 x_1 + b_2 x_2 + \cdots + b_n x_n + du.$$

This model can be represented in state space as

$$\frac{d}{dt} \begin{pmatrix} x_1 \\ x_2 \\ x_3 \\ \vdots \\ x_n \end{pmatrix} = \begin{pmatrix} -a_1 & -a_2 & \cdots & -a_{n-1} & -a_n \\ 1 & 0 & \cdots & 0 & 0 \\ 0 & 1 & & 0 & 0 \\ \vdots & & \ddots & & \vdots \\ 0 & 0 & & 1 & 0 \end{pmatrix} x + \begin{pmatrix} 1 \\ 0 \\ 0 \\ \vdots \\ 0 \end{pmatrix} u, \quad (3.8)$$

$$y = \begin{pmatrix} b_1 & b_2 & \cdots & b_n \end{pmatrix} x + du.$$

This particular form of a linear state space model is called *reachable canonical*

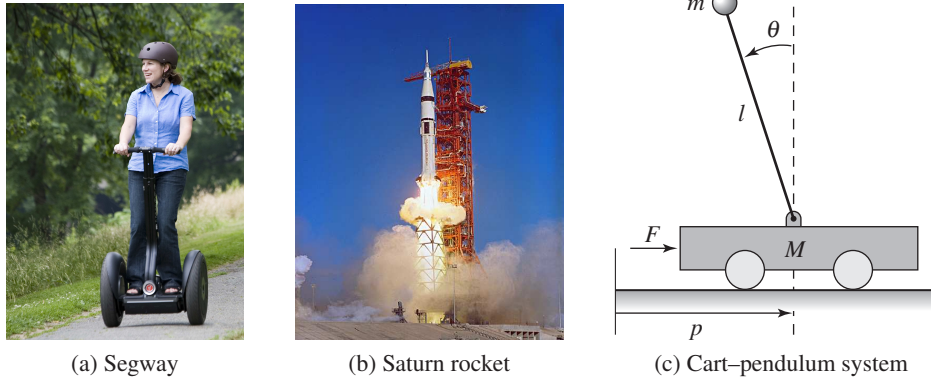

**Figure 3.6:** Balance systems. (a) Segway Personal Transporter, (b) Saturn rocket and (c) inverted pendulum on a cart. Each of these examples uses forces at the bottom of the system to keep it upright.

*form* and will be studied in more detail in later chapters. Many other representations for a model are possible and we shall see several of these in Chapters 6–8. It is also possible to expand the form of equation (3.7) to allow derivatives of the input to appear, as we shall see in Chapter 2.

### Example 3.1 Balance systems

An example of a type of system that can be modeled using ordinary differential equations is the class of *balance systems*. A balance system is a mechanical system in which the center of mass is balanced above a pivot point. Some common examples of balance systems are shown in Figure 3.6. The Segway® Personal Transporter (Figure 3.6a) uses a motorized platform to stabilize a person standing on top of it. When the rider leans forward, the transportation device propels itself along the ground but maintains its upright position. Another example is a rocket (Figure 3.6b), in which a gimbaled nozzle at the bottom of the rocket is used to stabilize the body of the rocket above it. Other examples of balance systems include humans or other animals standing upright or a person balancing a stick on their hand.

Balance systems are a generalization of the spring–mass system we saw earlier. We can write the dynamics for a mechanical system in the general form

$$M(q)\ddot{q} + C(q, \dot{q}) + K(q) = B(q)u,$$

where  $M(q)$  is the inertia matrix for the system,  $C(q, \dot{q})$  represents the Coriolis forces as well as the damping,  $K(q)$  gives the forces due to potential energy and  $B(q)$  describes how the external applied forces couple into the dynamics. Note that  $q$  may be a vector, rather than just a scalar, and represent the configuration variables of the system. The specific form of the equations can be derived using Newtonian mechanics. Each of the terms depends on the configuration of the system  $q$  and that these terms are often nonlinear in the configuration variables.

Figure 3.6c shows a simplified diagram for a balance system consisting of an

inverted pendulum on a cart. To model this system, we choose state variables that represent the position and velocity of the base of the system,  $p$  and  $\dot{p}$ , and the angle and angular rate of the structure above the base,  $\theta$  and  $\dot{\theta}$ . We let  $F$  represent the force applied at the base of the system, assumed to be in the horizontal direction (aligned with  $p$ ), and choose the position and angle of the system as outputs. With this set of definitions, the dynamics of the system can be computed using Newtonian mechanics and have the form

$$\begin{pmatrix} (M+m) & -ml \cos \theta \\ -ml \cos \theta & (J+ml^2) \end{pmatrix} \begin{pmatrix} \ddot{p} \\ \ddot{\theta} \end{pmatrix} + \begin{pmatrix} c\dot{p} + ml \sin \theta \dot{\theta}^2 \\ \gamma\dot{\theta} - mgl \sin \theta \end{pmatrix} = \begin{pmatrix} F \\ 0 \end{pmatrix}, \quad (3.9)$$

where  $M$  is the mass of the base,  $m$  and  $J$  are the mass and moment of inertia of the system to be balanced,  $l$  is the distance from the base to the center of mass of the balanced body,  $c$  and  $\gamma$  are coefficients of viscous friction and  $g$  is the acceleration due to gravity.

We can rewrite the dynamics of the system in state space form by defining the state as  $x = (p, \theta, \dot{p}, \dot{\theta})$ , the input as  $u = F$  and the output as  $y = (p, \theta)$ . If we define the total mass and total inertia as

$$M_t = M + m, \quad J_t = J + ml^2,$$

the equations of motion then become

$$\frac{d}{dt} \begin{pmatrix} p \\ \theta \\ \dot{p} \\ \dot{\theta} \end{pmatrix} = \begin{pmatrix} \dot{p} \\ \dot{\theta} \\ \frac{-mls_\theta \dot{\theta}^2 + mg(ml^2/J_t)s_\theta c_\theta - c\dot{p} - (\gamma/J_t)mlc_\theta \dot{\theta} + u}{M_t - m(ml^2/J_t)c_\theta^2} \\ \frac{-ml^2s_\theta c_\theta \dot{\theta}^2 + M_t g l s_\theta - clc_\theta \dot{p} - \gamma(M_t/m)\dot{\theta} + lc_\theta u}{J_t(M_t/m) - m(lc_\theta)^2} \end{pmatrix},$$

$$y = \begin{pmatrix} p \\ \theta \end{pmatrix},$$

where we have used the shorthand  $c_\theta = \cos \theta$  and  $s_\theta = \sin \theta$ .

In many cases, the angle  $\theta$  will be very close to 0, and hence we can use the approximations  $\sin \theta \approx \theta$  and  $\cos \theta \approx 1$ . Furthermore, if  $\dot{\theta}$  is small, we can ignore quadratic and higher terms in  $\dot{\theta}$ . Substituting these approximations into our equations, we see that we are left with a *linear* state space equation

$$\frac{d}{dt} \begin{pmatrix} p \\ \theta \\ \dot{p} \\ \dot{\theta} \end{pmatrix} = \begin{pmatrix} 0 & 0 & 1 & 0 \\ 0 & 0 & 0 & 1 \\ 0 & m^2 l^2 g / \mu & -cJ_t / \mu & -\gamma l m / \mu \\ 0 & M_t m g l / \mu & -clm / \mu & -\gamma M_t / \mu \end{pmatrix} \begin{pmatrix} p \\ \theta \\ \dot{p} \\ \dot{\theta} \end{pmatrix} + \begin{pmatrix} 0 \\ 0 \\ J_t / \mu \\ lm / \mu \end{pmatrix} u,$$

$$y = \begin{pmatrix} 1 & 0 & 0 & 0 \\ 0 & 1 & 0 & 0 \end{pmatrix} x,$$

where  $\mu = M_t J_t - m^2 l^2$ .

▽

**Example 3.2 Inverted pendulum**

A variation of the previous example is one in which the location of the base  $p$  does not need to be controlled. This happens, for example, if we are interested only in stabilizing a rocket's upright orientation without worrying about the location of base of the rocket. The dynamics of this simplified system are given by

$$\frac{d}{dt} \begin{pmatrix} \theta \\ \dot{\theta} \end{pmatrix} = \begin{pmatrix} \dot{\theta} \\ \frac{mgl}{J_t} \sin \theta - \frac{\gamma}{J_t} \dot{\theta} + \frac{l}{J_t} u \cos \theta \end{pmatrix}, \quad y = \theta, \quad (3.10)$$

where  $\gamma$  is the coefficient of rotational friction,  $J_t = J + ml^2$  and  $u$  is the force applied at the base. This system is referred to as an *inverted pendulum*.  $\nabla$

**Difference Equations**

In some circumstances, it is more natural to describe the evolution of a system at discrete instants of time rather than continuously in time. If we refer to each of these times by an integer  $k = 0, 1, 2, \dots$ , then we can ask how the state of the system changes for each  $k$ . Just as in the case of differential equations, we define the state to be the set of variables that summarizes the past of the system for the purpose of predicting its future. Systems described in this manner are referred to as *discrete-time systems*.

The evolution of a discrete-time system can be written in the form

$$x[k+1] = f(x[k], u[k]), \quad y[k] = h(x[k], u[k]), \quad (3.11)$$

where  $x[k] \in \mathbb{R}^n$  is the state of the system at time  $k$  (an integer),  $u[k] \in \mathbb{R}^p$  is the input and  $y[k] \in \mathbb{R}^q$  is the output. As before,  $f$  and  $h$  are smooth mappings of the appropriate dimension. We call equation (3.11) a *difference equation* since it tells us how  $x[k+1]$  differs from  $x[k]$ . The state  $x[k]$  can be either a scalar- or a vector-valued quantity; in the case of the latter we write  $x_j[k]$  for the value of the  $j$ th state at time  $k$ .

Just as in the case of differential equations, it is often the case that the equations are linear in the state and input, in which case we can describe the system by

$$x[k+1] = Ax[k] + Bu[k], \quad y[k] = Cx[k] + Du[k].$$

As before, we refer to the matrices  $A$ ,  $B$ ,  $C$  and  $D$  as the dynamics matrix, the control matrix, the sensor matrix and the direct term. The solution of a linear difference equation with initial condition  $x[0]$  and input  $u[0], \dots, u[T]$  is given by

$$\begin{aligned} x[k] &= A^k x[0] + \sum_{j=0}^{k-1} A^{k-j-1} B u[j], \\ y[k] &= C A^k x[0] + \sum_{j=0}^{k-1} C A^{k-j-1} B u[j] + D u[k], \end{aligned} \quad k > 0. \quad (3.12)$$



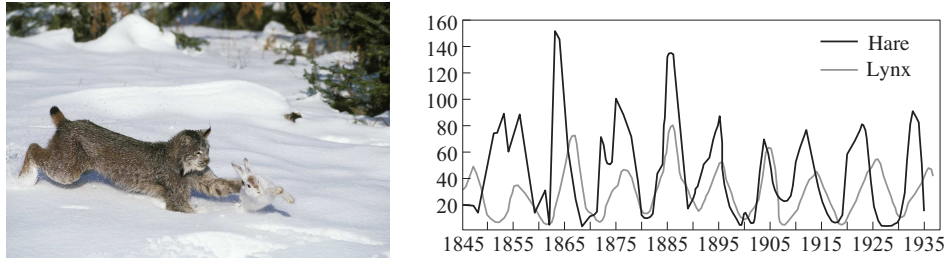

**Figure 3.7:** Predator versus prey. The photograph on the left shows a Canadian lynx and a snowshoe hare, the lynx’s primary prey. The graph on the right shows the populations of hares and lynxes between 1845 and 1935 in a section of the Canadian Rockies [Mac37]. The data were collected on an annual basis over a period of 90 years. (Photograph copyright Tom and Pat Leeson.)

Difference equations are also useful as an approximation of differential equations, as we will show later.

### Example 3.3 Predator–prey

As an example of a discrete-time system, consider a simple model for a predator–prey system. The predator–prey problem refers to an ecological system in which we have two species, one of which feeds on the other. This type of system has been studied for decades and is known to exhibit interesting dynamics. Figure 3.7 shows a historical record taken over 90 years for a population of lynxes versus a population of hares [Mac37]. As can be seen from the graph, the annual records of the populations of each species are oscillatory in nature.

A simple model for this situation can be constructed using a discrete-time model to keep track of the rate of births and deaths of each species. Letting  $H$  represent the population of hares and  $L$  represent the population of lynxes, we can describe the state in terms of the populations at discrete periods of time. Letting  $k$  be the discrete-time index (e.g., the day or month number), we can write

$$\begin{aligned} H[k+1] &= H[k] + b_r(u)H[k] - aL[k]H[k], \\ L[k+1] &= L[k] + cL[k]H[k] - d_fL[k], \end{aligned} \quad (3.13)$$

where  $b_r(u)$  is the hare birth rate per unit period and is a function of the food supply  $u$ ,  $d_f$  is the lynx mortality rate and  $a$  and  $c$  are the interaction coefficients. The interaction term  $aL[k]H[k]$  models the rate of predation, which is assumed to be proportional to the rate at which predators and prey meet and is hence given by the product of the population sizes. The interaction term  $cL[k]H[k]$  in the lynx dynamics has a similar form and represents the rate of growth of the lynx population. This model makes many simplifying assumptions—such as the fact that hares decrease in number only through predation by lynxes—but it often is sufficient to answer basic questions about the system.

To illustrate the use of this system, we can compute the number of lynxes and hares at each time point from some initial population. This is done by starting with  $x[0] = (H_0, L_0)$  and then using equation (3.13) to compute the populations in the

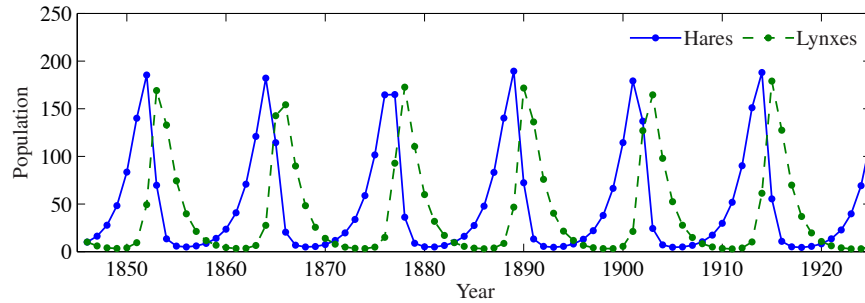

**Figure 3.8:** Discrete-time simulation of the predator–prey model (3.13). Using the parameters  $a = c = 0.014$ ,  $b_r(u) = 0.6$  and  $d = 0.7$  in equation (3.13) with daily updates, the period and magnitude of the lynx and hare population cycles approximately match the data in Figure 3.7.

following period. By iterating this procedure, we can generate the population over time. The output of this process for a specific choice of parameters and initial conditions is shown in Figure 3.8. While the details of the simulation are different from the experimental data (to be expected given the simplicity of our assumptions), we see qualitatively similar trends and hence we can use the model to help explore the dynamics of the system.  $\nabla$

#### Example 3.4 E-mail server

The IBM Lotus server is a collaborative software system that administers users’ e-mail, documents and notes. Client machines interact with end users to provide access to data and applications. The server also handles other administrative tasks. In the early development of the system it was observed that the performance was poor when the central processing unit (CPU) was overloaded because of too many service requests, and mechanisms to control the load were therefore introduced.

The interaction between the client and the server is in the form of remote procedure calls (RPCs). The server maintains a log of statistics of completed requests. The total number of requests being served, called `RIS` (RPCs in server), is also measured. The load on the server is controlled by a parameter called `MaxUsers`, which sets the total number of client connections to the server. This parameter is controlled by the system administrator. The server can be regarded as a dynamical system with `MaxUsers` as the input and `RIS` as the output. The relationship between input and output was first investigated by exploring the steady-state performance and was found to be linear.

In [HDPT04] a dynamic model in the form of a first-order difference equation is used to capture the dynamic behavior of this system. Using system identification techniques, they construct a model of the form

$$y[k + 1] = ay[k] + bu[k],$$

where  $u = \text{MaxUsers} - \overline{\text{MaxUsers}}$  and  $y = \text{RIS} - \overline{\text{RIS}}$ . The parameters  $a = 0.43$  and  $b = 0.47$  are parameters that describe the dynamics of the system around

the operating point, and  $\overline{\text{MaxUsers}} = 165$  and  $\overline{\text{RIS}} = 135$  represent the nominal operating point of the system. The number of requests was averaged over a sampling period of 60 s.  $\nabla$

Another application of difference equation is in the implementation of control systems on computers. Early controllers were analog physical systems, which can be modeled by differential equations. When implementing a controller described by a differential equation using a computer it is necessary to do approximations. A simple way is to approximate derivatives by finite differences, as illustrated by the following example.

### Example 3.5 Difference approximation of a PI controller

Consider the PI controller

$$u(t) = k_p e(t) + k_i \int_0^t e(\tau) d\tau = k_p e(t) + x(t), \quad x = k_i \int_0^t e(\tau) d\tau,$$

where the controller state is given by the differential equation

$$\frac{dx}{dt} = k_i e(t) \quad (3.14)$$

Assume that the error is measured at regular sampling intervals  $t = h, 2h, 3h, \dots$ . Approximating the derivative in equation (3.14) by differences gives

$$\frac{x(kh+h) - x(kh)}{h} = k_i e(kh),$$

and the controller is then given by the difference equation

$$x[k+1] = x[k] + hk_i e[k], \quad u[k] = k_p e[k] + x[k],$$

where  $x[k] = x(kh)$ ,  $e[k] = e(kh)$  and  $u[k] = u(kh)$  represent the discrete-time state, error and input sampled at each time interval. This controller is easy to implement on a computer since it consists of just addition and multiplication.  $\nabla$

The approximation in the example works well provided that the sampling interval is so short that the variable  $e(t)$  changes very little over a sampling interval.

## Finite State Machines



A finite state machine is a model in which the states of the system are chosen from a finite list of “modes”. The dynamics of a finite state machine are given by transitions between these modes, possibly in response to external signals. We illustrate this concept with a simple example.

### Example 3.6 Traffic light controller

Consider a finite state machine model of a traffic light control system, as shown in Figure 3.6. We represent the state of the system in terms of the set of traffic lights that are turned on (either east–west or north–south). In addition, once a light is turned on it should stay that way for a certain minimum time, and then only change when a car comes up to the intersection in the opposite direction. This

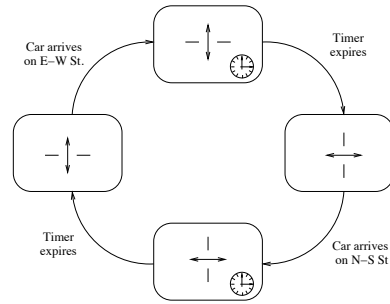

**Figure 3.9:** A simple model for a traffic light. The diagram on the right is a finite state machine model of the traffic light controller.

gives us two states for each direction of the lights: waiting for a car to arrive and waiting for the timer to expire. Thus, we have four states for the system, as show in Figure 3.6.

The dynamics for the light describe how the system transitions from one state to another. Starting at the left most state, we assume that the lights are set to allow traffic in the north–south direction. When a car arrives on the east–west street, we transition to the state at the top of the diagram, where a timer is started. Once the timer reaches the designated amount of time, we transition to the state on the right side of the diagram and turn on the lights in the east–west direction. From here we wait until a car arrives on the north–south street and continue the cycle.

Viewed as a control system, this model has a state space consisting of four discrete states: north–south waiting, north–south countdown, east–west waiting, and east–west countdown. The inputs to the controller consist of the signals that indicate whether a car is present at the roads leading up to the intersection. The outputs from the controller are the signals that change the colors of the traffic light. Finally, the dynamics of the controller are the transition diagram that controls how the states (or modes) of the system change in time.  $\nabla$

More formally, a finite state machine can be represented as a finite set of discrete states  $\alpha \in \mathbb{Q}_{\text{sys}}$ , where  $\mathbb{Q}_{\text{sys}}$  is a discrete set. The dynamics of the system are described by transitions between the discrete states, as in the finite state machine described in the previous example. These transitions can depend on external inputs or measurements and can generate output actions on transition into or out of a given state. If we let  $\beta \in \mathbb{Q}_{\text{in}}$  represent (discrete) input events (button press, component failure, etc) and  $\gamma \in \mathbb{Q}_{\text{out}}$  represent (discrete) output actions (such as turning off of device), then the dynamics of the finite state machine can be written as a guarded command system

$$g_i(\alpha, \beta) \implies \begin{cases} \alpha' = r_i(\alpha, \beta), \\ \gamma = a_i(\alpha, \beta), \end{cases} \quad i = 1, \dots, N. \quad (3.15)$$

Here the function  $g$  is a Boolean (true/false) function that depends on the current system mode  $\alpha$  and an external input  $\beta$ . If the guard  $g_i$  is true then the system

transitions from the current state  $\alpha$  to a new state  $\alpha'$ , determined by the rule (transition map)  $r_i$  and the external input. The output action  $\gamma$  is similarly dependent on the current state and external input. A guarded transition system can have many different rules, depending on the system state and external input.

The dynamics of a transition system is similar in many ways to the discrete time dynamics in equation (3.11). The major difference is that the transitions do not necessarily occur at regularly spaced intervals of time. Indeed, there is no strict notion of time in a transition system as we have described it here: it is only the sequence of events that is kept track of (through the evolution of the discrete state).

Specifications for finite transition systems are often written as logical functions describing the conditions that should be imposed on the system. For example, we might wish to say that if a specific sensor is not operating, then the system cannot transition to a mode that requires the use of that sensor. This could be written as the logical formula

$$\alpha \in \{\text{states with sensor } k \text{ not functioning}\} \implies \alpha \notin \{\text{states requiring sensor } k\}.$$

The formula of the form  $p \implies q$  where  $p$  and  $q$  are Boolean propositions can be written as the logical function  $(!p) \vee (p \wedge q)$ , which asserts that if proposition  $p$  is true then proposition  $q$  must be true. In the sensor example,  $p$  and  $q$  are represented by whether the system mode  $\alpha$  is in some set of states.

Finite state machines are very useful for describing logical operations and are often combined with continuous state models (differential or difference equations) to create a hybrid system model. The study of hybrid systems is beyond the scope of this text, but excellent references include Lee and Seshia [LS15] and Alur [Alu15].

### Simulation and Analysis

State space models can be used to answer many questions. One of the most common, as we have seen in the previous examples, involves predicting the evolution of the system state from a given initial condition. While for simple models this can be done in closed form, more often it is accomplished through computer simulation.

Consider again the damped spring–mass system from Section 3.1, but this time with an external force applied, as shown in Figure 3.10. We wish to predict the motion of the system for a periodic forcing function, with a given initial condition, and determine the amplitude, frequency and decay rate of the resulting motion.

We choose to model the system with a linear ordinary differential equation. Using Hooke’s law to model the spring and assuming that the damper exerts a force that is proportional to the velocity of the system, we have

$$m\ddot{q} + c\dot{q} + kq = u, \tag{3.16}$$

where  $m$  is the mass,  $q$  is the displacement of the mass,  $c$  is the coefficient of viscous friction,  $k$  is the spring constant and  $u$  is the applied force. In state space

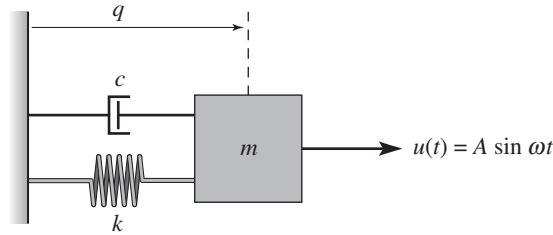

**Figure 3.10:** A driven spring–mass system with damping. Here we use a linear damping element with coefficient of viscous friction  $c$ . The mass is driven with a sinusoidal force of amplitude  $A$ .

form, using  $x = (q, \dot{q})$  as the state and choosing  $y = q$  as the output, we have

$$\frac{dx}{dt} = \begin{pmatrix} x_2 \\ -\frac{c}{m}x_2 - \frac{k}{m}x_1 + \frac{u}{m} \end{pmatrix}, \quad y = x_1.$$

We see that this is a linear second-order differential equation with one input  $u$  and one output  $y$ .

We now wish to compute the response of the system to an input of the form  $u = A \sin \omega t$ . Although it is possible to solve for the response analytically, we instead make use of a computational approach that does not rely on the specific form of this system. Consider the general state space system

$$\frac{dx}{dt} = f(x, u).$$

Given the state  $x$  at time  $t$ , we can approximate the value of the state at a short time  $h > 0$  later by assuming that the rate of change  $f(x, u)$  is constant over the interval  $t$  to  $t + h$ . This gives

$$x(t+h) = x(t) + hf(x(t), u(t)). \quad (3.17)$$

Iterating this equation, we can thus solve for  $x$  as a function of time. This approximation is known as Euler integration and is in fact a difference equation if we let  $h$  represent the time increment and write  $x[k] = x(kh)$ , as we saw in Example 3.5. Although modern simulation tools such as MATLAB and Mathematica use more accurate methods than Euler integration, they still have some of the same basic trade-offs.

Returning to our specific example, Figure 3.11 shows the results of computing  $x(t)$  using equation (3.17), along with the analytical computation. We see that as  $h$  gets smaller, the computed solution converges to the exact solution. The form of the solution is also worth noticing: after an initial transient, the system settles into a periodic motion. The portion of the response after the transient is called the *steady-state response* to the input.

In addition to generating simulations, models can also be used to answer other types of questions. Two that are central to the methods described in this text concern the stability of an equilibrium point and the input/output frequency response.

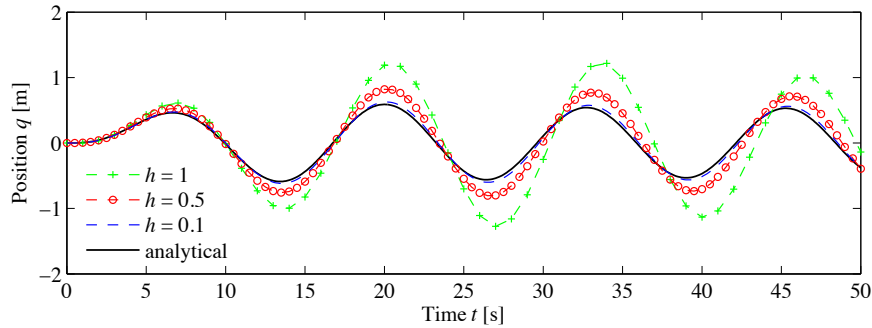

**Figure 3.11:** Simulation of the forced spring–mass system with different simulation time constants. The solid line represents the analytical solution. The dashed lines represent the approximate solution via the method of Euler integration, using decreasing step sizes.

We illustrate these two computations through the examples below and return to the general computations in later chapters.

Returning to the damped spring–mass system, the equations of motion with no input forcing are given by

$$\frac{dx}{dt} = \begin{pmatrix} x_2 \\ -\frac{c}{m}x_2 - \frac{k}{m}x_1 \end{pmatrix}, \quad (3.18)$$

where  $x_1$  is the position of the mass (relative to the rest position) and  $x_2$  is its velocity. We wish to show that if the initial state of the system is away from the rest position, the system will return to the rest position eventually (we will later define this situation to mean that the rest position is *asymptotically stable*). While we could heuristically show this by simulating many, many initial conditions, we seek instead to prove that this is true for *any* initial condition.

To do so, we construct a function  $V : \mathbb{R}^n \rightarrow \mathbb{R}$  that maps the system state to a positive real number. For mechanical systems, a convenient choice is the energy of the system,

$$V(x) = \frac{1}{2}kx_1^2 + \frac{1}{2}mx_2^2. \quad (3.19)$$

If we look at the time derivative of the energy function, we see that

$$\frac{dV}{dt} = kx_1\dot{x}_1 + mx_2\dot{x}_2 = kx_1x_2 + mx_2\left(-\frac{c}{m}x_2 - \frac{k}{m}x_1\right) = -cx_2^2,$$

which is always either negative or zero. Hence  $V(x(t))$  is never increasing and, using a bit of analysis that we will see formally later, the individual states must remain bounded.

If we wish to show that the states eventually return to the origin, we must use a slightly more detailed analysis. Intuitively, we can reason as follows: suppose that for some period of time,  $V(x(t))$  stops decreasing. Then it must be true that  $\dot{V}(x(t)) = 0$ , which in turn implies that  $x_2(t) = 0$  for that same period. In that case,

$\dot{x}_2(t) = 0$ , and we can substitute into the second line of equation (3.18) to obtain

$$0 = \dot{x}_2 = -\frac{c}{m}x_2 - \frac{k}{m}x_1 = -\frac{k}{m}x_1.$$

Thus we must have that  $x_1$  also equals zero, and so the only time that  $V(x(t))$  can stop decreasing is if the state is at the origin (and hence this system is at its rest position). Since we know that  $V(x(t))$  is never increasing (because  $\dot{V} \leq 0$ ), we therefore conclude that the origin is stable (for *any* initial condition).

This type of analysis, called Lyapunov stability analysis, is considered in detail in Chapter 5. It shows some of the power of using models for the analysis of system properties.

Another type of analysis that we can perform with models is to compute the output of a system to a sinusoidal input, known as the *frequency response*. We again consider the spring–mass system, but this time keeping the input and leaving the system in its original form:

$$m\ddot{q} + c\dot{q} + kq = u. \quad (3.20)$$

We wish to understand how the system responds to a sinusoidal input of the form

$$u(t) = A \sin \omega t.$$

We will see how to do this analytically in Chapter 7, but for now we make use of simulations to compute the answer.

We first begin with the observation that if  $q(t)$  is the solution to equation (3.20) with input  $u(t)$ , then applying an input  $2u(t)$  will give a solution  $2q(t)$  (this is easily verified by substitution). Hence it suffices to look at an input with unit magnitude,  $A = 1$ . A second observation, which we will prove in Chapter 6, is that the long-term response of the system to a sinusoidal input is itself a sinusoid at the same frequency, and so the output has the form

$$q(t) = g(\omega) \sin(\omega t + \varphi(\omega)),$$

where  $g(\omega)$  is called the *gain* of the system and  $\varphi(\omega)$  is called the *phase* (or phase offset).

To compute the frequency response numerically, we can simulate the system at a set of frequencies  $\omega_1, \dots, \omega_N$  and plot the gain and phase at each of these frequencies. An example of this type of computation is shown in Figure 3.12. For linear systems the frequency response does not depend on the amplitude  $A$  of the input signal. Frequency response can also be applied to nonlinear systems but the gain and phase then depend on the  $A$ .

### 3.3 Modeling Methodology

To deal with large, complex systems, it is useful to have different representations of the system that capture the essential features and hide irrelevant details. In all branches of science and engineering it is common practice to use some graphical



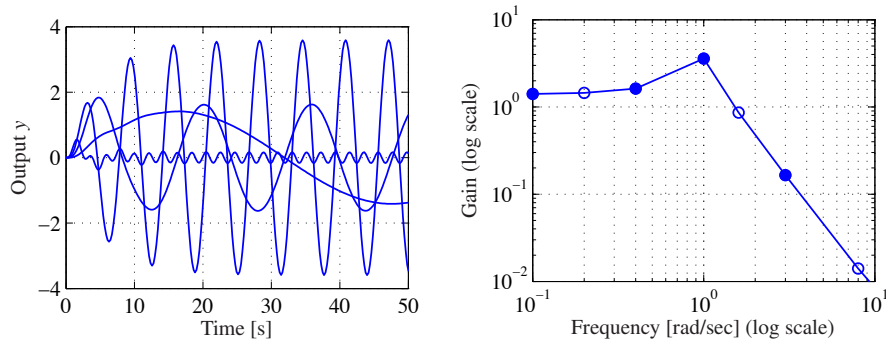

**Figure 3.12:** A frequency response (gain only) computed by measuring the response of individual sinusoids. The figure on the left shows the response of the system as a function of time to a number of different unit magnitude inputs (at different frequencies). The figure on the right shows this same data in a different way, with the magnitude of the response plotted as a function of the input frequency. The filled circles correspond to the particular frequencies shown in the time responses.

description of systems, called *schematic diagrams*. They can range from stylistic pictures to drastically simplified standard symbols. These pictures make it possible to get an overall view of the system and to identify the individual components. Examples of such diagrams are shown in Figure 3.13. Schematic diagrams are useful because they give an overall picture of a system, showing different subprocesses and their interconnection and indicating variables that can be manipulated and signals that can be measured.

### Block Diagrams

A special graphical representation called a *block diagram* has been developed in control engineering. The purpose of a block diagram is to emphasize the information flow and to hide details of the system. In a block diagram, different process elements are shown as boxes, and each box has inputs denoted by lines with arrows pointing toward the box and outputs denoted by lines with arrows going out of the box. The inputs denote the variables that influence a process, and the outputs denote the signals that we are interested in or signals that influence other subsystems. Block diagrams can also be organized in hierarchies, where individual blocks may themselves contain more detailed block diagrams.

Figure 3.14 shows some of the notation that we use for block diagrams. Signals are represented as lines, with arrows to indicate inputs and outputs. The first diagram is the representation for a summation of two signals. An input/output response is represented as a rectangle with the system name (or mathematical description) in the block. Two special cases are a proportional gain, which scales the input by a multiplicative factor, and an integrator, which outputs the integral of the input signal.

Figure 3.15 illustrates the use of a block diagram, in this case for modeling the flight response of a fly. The flight dynamics of an insect are incredibly intricate,



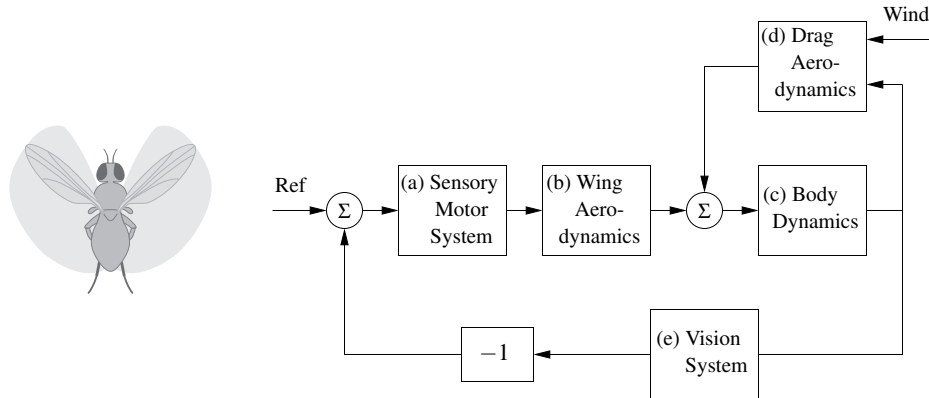

**Figure 3.15:** A block diagram representation of the flight control system for an insect flying against the wind. The mechanical portion of the model consists of the rigid-body dynamics of the fly, the drag due to flying through the air and the forces generated by the wings. The motion of the body causes the visual environment of the fly to change, and this information is then used to control the motion of the wings (through the sensory motor system), closing the loop.

involving careful coordination of the muscles within the fly to maintain stable flight in response to external stimuli. One known characteristic of flies is their ability to fly upwind by making use of the optical flow in their compound eyes as a feedback mechanism. Roughly speaking, the fly controls its orientation so that the point of contraction of the visual field is centered in its visual field.

To understand this complex behavior, we can decompose the overall dynamics of the system into a series of interconnected subsystems (or *blocks*). Referring to Figure 3.15, we can model the insect navigation system through an interconnection of five blocks. The sensory motor system (a) takes the information from the visual system (e) and generates muscle commands that attempt to steer the fly so that the point of contraction is centered. These muscle commands are converted into forces through the flapping of the wings (b) and the resulting aerodynamic forces that are produced. The forces from the wings are combined with the drag on the fly (d) to produce a net force on the body of the fly. The wind velocity enters through the drag aerodynamics. Finally, the body dynamics (c) describe how the fly translates and rotates as a function of the net forces that are applied to it. The insect position, speed and orientation are fed back to the drag aerodynamics and vision system blocks as inputs.

Each of the blocks in the diagram can itself be a complicated subsystem. For example, the visual system of a fruit fly consists of two complicated compound eyes (with about 700 elements per eye), and the sensory motor system has about 200,000 neurons that are used to process information. A more detailed block diagram of the insect flight control system would show the interconnections between these elements, but here we have used one block to represent how the motion of the fly affects the output of the visual system, and a second block to represent how the visual field is processed by the fly's brain to generate muscle commands. The

choice of the level of detail of the blocks and what elements to separate into different blocks often depends on experience and on the questions that one wants to answer using the model. One of the powerful features of block diagrams is their ability to hide information about the details of a system that may not be needed to gain an understanding of the essential dynamics of the system.

### Algebraic Loops

When analyzing or simulating a system described by a block diagram, we need to form the differential equations that describe the complete system. In many cases the equations can be obtained by combining the differential equations that describe each subsystem and substituting variables. This simple procedure cannot be used when there are closed loops of subsystems that all have a direct connection between inputs and outputs, known as an *algebraic loop*. A *direct connection* means that a change in the output  $u$  gives an instantaneous change in the output  $y$ . The systems (3.5) and (3.6) have no direct connection if  $h_u(x, u) = 0$  and  $D = 0$  respectively.

To see what can happen, consider a system with two blocks, a first-order non-linear system,

$$\frac{dx}{dt} = f(x, u), \quad y = h(x), \quad (3.21)$$

and a proportional controller described by  $u = -ky$ . There is no direct term since the function  $h$  does not depend on  $u$ . In that case we can obtain the equation for the closed loop system simply by replacing  $u$  by  $-ky = -kh(x)$  in equation (3.21) to give

$$\frac{dx}{dt} = f(x, -kh(x)), \quad y = h(x),$$

which is an ordinary differential equation.

The situation is more complicated if there is a direct term. If  $y = h(x, u)$ , then replacing  $u$  by  $-ky$  gives

$$\frac{dx}{dt} = f(x, -ky), \quad y = h(x, -ky).$$

To obtain a differential equation for  $x$ , the algebraic equation  $y = h(x, -ky)$  must be first be solved to give  $y = \alpha(x)$ , which in general is a complicated task.

When algebraic loops are present, it is necessary to solve algebraic equations to obtain the differential equations for the complete system. The resulting model becomes a set of differential algebraic equation, similar to equation 3.4. Resolving algebraic loops is a nontrivial problem because it requires the symbolic solution of algebraic equations. Most block diagram-oriented modeling languages cannot handle algebraic loops, and they simply give a diagnosis that such loops are present. In the era of analog computing, algebraic loops were eliminated by introducing fast dynamics between the loops. This created differential equations with fast and slow modes that are difficult to solve numerically. Advanced modeling languages like Modelica use several sophisticated methods to resolve algebraic loops.

### Modeling from Experiments

Since control systems are provided with sensors and actuators, it is also possible to obtain models of system dynamics from experiments on the process. The models are restricted to input/output models since only these signals are accessible to experiments, but modeling from experiments can also be combined with modeling from physics through the use of feedback and interconnection.

A simple way to determine a system's dynamics is to observe the response to a step change in the control signal. Such an experiment begins by setting the control signal to a constant value; then when steady state is established, the control signal is changed quickly to a new level and the output is observed. The experiment gives the step response of the system, and the shape of the response gives useful information about the dynamics. It immediately gives an indication of the response time, and it tells if the system is oscillatory or if the response is monotone.

#### Example 3.7 Spring–mass system

The dynamics of the spring–mass system in Section 3.1 are given by

$$m\ddot{q} + c\dot{q} + kq = u. \quad (3.22)$$

We wish to determine the constants  $m$ ,  $c$  and  $k$  by measuring the response of the system to a step input of magnitude  $F_0$ .

We will show in Chapter 7 that when  $c^2 < 4km$ , the step response for this system from the rest configuration is given by

$$q(t) = \frac{F_0}{k} \left( 1 - \frac{1}{\omega_d} \sqrt{\frac{k}{m}} \exp\left(-\frac{ct}{2m}\right) \sin(\omega_d t + \varphi) \right),$$

$$\omega_d = \frac{\sqrt{4km - c^2}}{2m}, \quad \varphi = \tan^{-1} \left( \frac{\sqrt{4km - c^2}}{c} \right).$$

From the form of the solution, we see that the shape of the step response is determined by the parameters of the system. Hence, by measuring certain features of the step response we can determine the parameter values.

Figure 3.16 shows the response of the system to a step of magnitude  $F_0 = 20$  N, along with some measurements. We start by noting that the steady-state position of the mass (after the oscillations die down) is a function of the spring constant  $k$ :

$$q(\infty) = \frac{F_0}{k}, \quad (3.23)$$

where  $F_0$  is the magnitude of the applied force ( $F_0 = 1$  for a unit step input). The parameter  $1/k$  is called the *gain* of the system. The period of the oscillation can be measured between two peaks and must satisfy

$$\frac{2\pi}{T} = \frac{\sqrt{4km - c^2}}{2m}. \quad (3.24)$$

Finally, the rate of decay of the oscillations is given by the exponential factor in

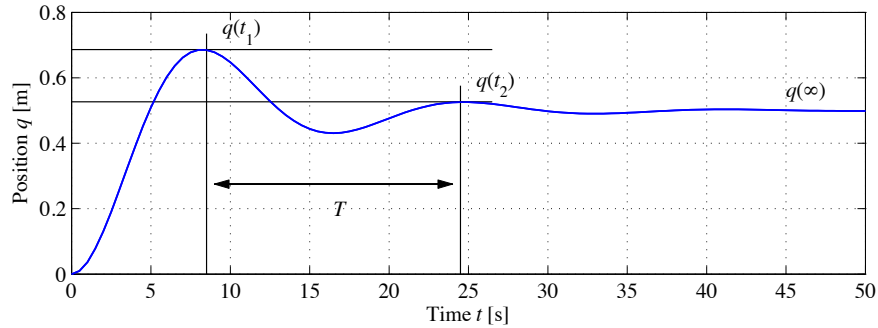

**Figure 3.16:** Step response for a spring–mass system. The magnitude of the step input is  $F_0 = 20$  N. The period of oscillation  $T$  is determined by looking at the time between two subsequent local maxima in the response. The period combined with the steady-state value  $q(\infty)$  and the relative decrease between local maxima can be used to estimate the parameters in a model of the system.

the solution. Measuring the amount of decay between two peaks, we have

$$\log\left(q(t_1) - \frac{F_0}{k}\right) - \log\left(q(t_2) - \frac{F_0}{k}\right) = \frac{c}{2m}(t_2 - t_1). \quad (3.25)$$

Using this set of three equations, we can solve for the parameters and determine that for the step response in Figure 3.16 we have  $m \approx 250$  kg,  $c \approx 60$  N s/m and  $k \approx 40$  N/m.  $\nabla$

Modeling from experiments can also be done using many other signals. Sinusoidal signals are commonly used (particularly for systems with fast dynamics) and precise measurements can be obtained by exploiting correlation techniques. An indication of nonlinearities can be obtained by repeating experiments with input signals having different amplitudes. Modeling based on sinusoidal signal is very time consuming for systems with slow dynamics. In such situations it is advantageous to use signals that switch between two different levels. There is a whole subfield of control called *system identification* that deals with experimental determination of models. Questions like optimal inputs, experiments in open and closed loop, model accuracy and fundamental limitations are dealt with extensively.

### Normalization and Scaling

When deriving a model, it is often useful to introduce dimension-free variables. Such a procedure can often simplify the equations for a system by reducing the number of parameters. It can also reveal interesting properties of the model. It is also useful to normalize variables by scaling to improve numerics and allow faster and more accurate simulations.

The procedure of scaling is straightforward in principle: choose units for each independent variable and introduce new variables by dividing the variables by the chosen normalization unit. We illustrate the procedure with two examples.

**Example 3.8 Spring–mass system**

Consider again the spring–mass system introduced earlier. Neglecting the damping, the system is described by

$$m\ddot{q} + kq = u.$$

The model has two parameters  $m$  and  $k$ . To normalize the model we introduce dimension-free variables  $x = q/l$  and  $\tau = \omega_0 t$ , where  $\omega_0 = \sqrt{k/m}$  and  $l$  is the chosen length scale. We scale force by  $ml\omega_0^2$  and introduce  $v = u/(ml\omega_0^2)$ . The scaled equation then becomes

$$\frac{d^2x}{d\tau^2} = \frac{d^2q/l}{d(\omega_0 t)^2} = \frac{1}{ml\omega_0^2}(-kq + u) = -x + v,$$

which is the normalized undamped spring–mass system. Notice that the normalized model has no parameters, while the original model had two parameters  $m$  and  $k$ . Introducing the scaled, dimension-free state variables  $z_1 = x = q/l$  and  $z_2 = dx/d\tau = \dot{q}/(l\omega_0)$ , the model can be written as

$$\frac{d}{dt} \begin{pmatrix} z_1 \\ z_2 \end{pmatrix} = \begin{pmatrix} 0 & 1 \\ -1 & 0 \end{pmatrix} \begin{pmatrix} z_1 \\ z_2 \end{pmatrix} + \begin{pmatrix} 0 \\ v \end{pmatrix}.$$

This simple linear equation describes the dynamics of any spring–mass system, independent of the particular parameters, and hence gives us insight into the fundamental dynamics of this oscillatory system. To recover the physical frequency of oscillation or its magnitude, we must invert the scaling we have applied.  $\nabla$

**Example 3.9 Balance system**

Consider the balance system described in Section 3.1. Neglecting damping by putting  $c = 0$  and  $\gamma = 0$  in equation (3.9), the model can be written as

$$\begin{aligned} (M + m)\frac{d^2p}{dt^2} - ml \cos \theta \frac{d^2\theta}{dt^2} + ml \sin \theta \left(\frac{d\theta}{dt}\right)^2 &= F, \\ -ml \cos \theta \frac{d^2p}{dt^2} + (J + ml^2)\frac{d^2\theta}{dt^2} - mgl \sin \theta &= 0. \end{aligned}$$

Let  $\omega_0 = \sqrt{mgl/(J + ml^2)}$ , choose the length scale as  $l$ , let the time scale be  $1/\omega_0$ , choose the force scale as  $(M + m)l\omega_0^2$  and introduce the scaled variables  $\tau = \omega_0 t$ ,  $x = p/l$  and  $u = F/((M + m)l\omega_0^2)$ . The equations then become

$$\frac{d^2x}{d\tau^2} - \alpha \cos \theta \frac{d^2\theta}{d\tau^2} + \alpha \sin \theta \left(\frac{d\theta}{d\tau}\right)^2 = u, \quad -\beta \cos \theta \frac{d^2x}{d\tau^2} + \frac{d^2\theta}{d\tau^2} - \sin \theta = 0,$$

where  $\alpha = m/(M + m)$  and  $\beta = ml^2/(J + ml^2)$ . Notice that the original model has five parameters  $m, M, J, l$  and  $g$  but the normalized model has only two parameters  $\alpha$  and  $\beta$ . If  $M \gg m$  and  $ml^2 \gg J$ , we get  $\alpha \approx 0$  and  $\beta \approx 1$  and the model can be approximated by

$$\frac{d^2x}{d\tau^2} = u, \quad \frac{d^2\theta}{d\tau^2} - \sin \theta = u \cos \theta.$$

The model can be interpreted as a mass combined with an inverted pendulum driven by the same input.  $\nabla$

For large systems scaling is not so easy, there are many choices and good selection of variables and normalization units require good understanding of the physics of the system and the numerical methods that will be used for analysis, scaling of large systems is therefor still an art.

### 3.4 Modeling Examples

In this section we introduce additional examples that illustrate some of the different types of systems for which one can develop differential equation and difference equation models. These examples are specifically chosen from a range of different fields to highlight the broad variety of systems to which feedback and control concepts can be applied. A more detailed set of applications that serve as running examples throughout the text are given in Chapter 4.

#### Motion Control Systems

Motion control systems involve the use of computation and feedback to control the movement of a mechanical system. Motion control systems range from nanopositioning systems (atomic force microscopes, adaptive optics), to control systems for the read/write heads in a disk drive of a CD player, to manufacturing systems (transfer machines and industrial robots), to automotive control systems (antilock brakes, suspension control, traction control), to air and space flight control systems (airplanes, satellites, rockets and planetary rovers).

#### Example 3.10 Vehicle steering

A common problem in motion control is to control the trajectory of a vehicle through an actuator that causes a change in the orientation. A steering wheel on an automobile and the front wheel of a bicycle are two examples, but similar dynamics occur in the steering of ships or control of the pitch dynamics of an aircraft. In many cases, we can understand the basic behavior of these systems through the use of a simple model that captures the basic kinematics of the system.

Consider a vehicle with two wheels as shown in Figure 3.17. For the purpose of steering we are interested in a model that describes how the velocity of the vehicle depends on the steering angle  $\delta$ . To be specific, let  $b$  be the wheel base and consider the velocity  $v$  at the center of mass, a distance  $a$  from the rear wheel, as shown in Figure 3.17. Let  $x$  and  $y$  be the coordinates of the center of mass,  $\theta$  the heading angle and  $\alpha$  the angle between the velocity vector  $v$  and the centerline of the vehicle. The point  $O$  is at the intersection of the normals to the front and rear wheels. The distance from  $O$  to the center of mass is  $r_a$ .

Assuming no slipping of the wheels the motion is a rotation around the point  $O$  in the figure. Since  $b = r_a \tan \delta$  and  $a = r_a \tan \alpha$ , it follows that  $\tan \alpha = (a/b) \tan \delta$



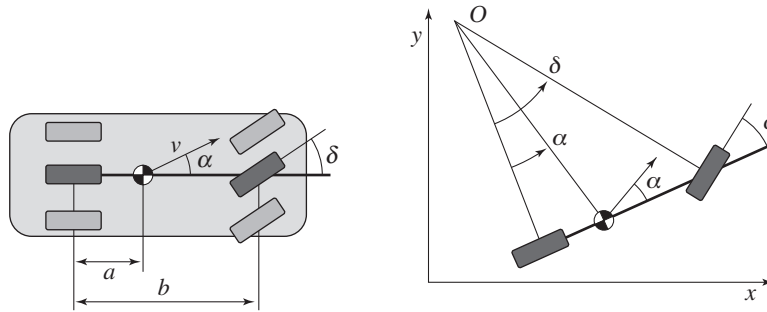

**Figure 3.17:** Vehicle steering dynamics. The left figure shows an overhead view of a vehicle with four wheels. The wheel base is  $b$  and the center of mass is at a distance  $a$  forward of the rear wheels. By approximating the motion of the front and rear pairs of wheels by a single front wheel and a single rear wheel, we obtain an abstraction called the *bicycle model*, shown on the right. The steering angle is  $\delta$  and the velocity at the center of mass has the angle  $\alpha$  relative to the length axis of the vehicle. The position of the vehicle is given by  $(x, y)$  and the orientation (heading) by  $\theta$ .

and we get the following relation between  $\alpha$  and the steering angle  $\delta$ :

$$\alpha = \arctan\left(\frac{a \tan \delta}{b}\right). \quad (3.26)$$

Assume that the wheels are rolling without slip and that the velocity of the rear wheel is  $v_0$ . The vehicle speed at its center of mass is  $v = v_0 / \cos \alpha$ , and we find that the motion of this point is given by

$$\begin{aligned} \frac{dx}{dt} &= v \cos(\alpha + \theta) = v_0 \frac{\cos(\alpha + \theta)}{\cos \alpha}, \\ \frac{dy}{dt} &= v \sin(\alpha + \theta) = v_0 \frac{\sin(\alpha + \theta)}{\cos \alpha}. \end{aligned} \quad (3.27)$$

To see how the angle  $\theta$  is influenced by the steering angle, we observe from Figure 3.17 that the vehicle rotates with the angular velocity  $v_0/r_a$  around the point  $O$ . Hence

$$\frac{d\theta}{dt} = \frac{v_0}{r_a} = \frac{v_0}{b} \tan \delta. \quad (3.28)$$

Equations (3.26)–(3.28) can be used to model an automobile under the assumptions that there is no slip between the wheels and the road and that the two front wheels can be approximated by a single wheel at the center of the car. This model is often called the *bicycle model*. The assumption of no slip can be relaxed by adding an extra state variable, giving a more realistic model. Such a model also describes the steering dynamics of ships as well as the pitch dynamics of aircraft and missiles. It is also possible to choose coordinates so that the reference point is at the rear wheels (corresponding to setting  $\alpha = 0$ ), a model often referred to as the *Dubins car* [Dub57].

Figure 3.17 represents the situation when the vehicle moves forward and has



(a) Harrier “jump jet”

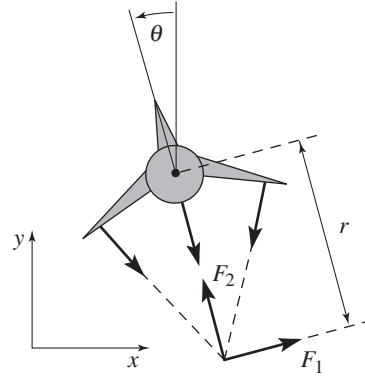

(b) Simplified model

**Figure 3.18:** Vectored thrust aircraft. The Harrier AV-8B military aircraft (a) redirects its engine thrust downward so that it can “hover” above the ground. Some air from the engine is diverted to the wing tips to be used for maneuvering. As shown in (b), the net thrust on the aircraft can be decomposed into a horizontal force  $F_1$  and a vertical force  $F_2$  acting at a distance  $r$  from the center of mass.

front-wheel steering. The figure shows that the model also applies to rear wheel steering if the sign of the velocity is reversed.  $\nabla$

### Example 3.11 Vectored thrust aircraft

Consider the motion of vectored thrust aircraft, such as the Harrier “jump jet” shown Figure 3.18a. The Harrier is capable of vertical takeoff by redirecting its thrust downward and through the use of smaller maneuvering thrusters located on its wings. A simplified model of the Harrier is shown in Figure 3.18b, where we focus on the motion of the vehicle in a vertical plane through the wings of the aircraft. We resolve the forces generated by the main downward thruster and the maneuvering thrusters as a pair of forces  $F_1$  and  $F_2$  acting at a distance  $r$  below the aircraft (determined by the geometry of the thrusters).

Let  $(x, y, \theta)$  denote the position and orientation of the center of mass of the aircraft. Let  $m$  be the mass of the vehicle,  $J$  the moment of inertia,  $g$  the gravitational constant and  $c$  the damping coefficient. Then the equations of motion for the vehicle are given by

$$\begin{aligned} m\ddot{x} &= F_1 \cos \theta - F_2 \sin \theta - c\dot{x}, \\ m\ddot{y} &= F_1 \sin \theta + F_2 \cos \theta - mg - c\dot{y}, \\ J\ddot{\theta} &= rF_1. \end{aligned} \quad (3.29)$$

It is convenient to redefine the inputs so that the origin is an equilibrium point of the system with zero input. Letting  $u_1 = F_1$  and  $u_2 = F_2 - mg$ , the equations become

$$\begin{aligned} m\ddot{x} &= -mg \sin \theta - c\dot{x} + u_1 \cos \theta - u_2 \sin \theta, \\ m\ddot{y} &= mg(\cos \theta - 1) - c\dot{y} + u_1 \sin \theta + u_2 \cos \theta, \\ J\ddot{\theta} &= ru_1. \end{aligned} \quad (3.30)$$

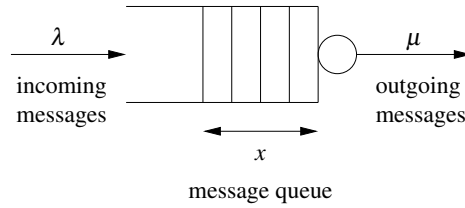

**Figure 3.19:** Schematic diagram of a queuing system. Messages arrive at rate  $\lambda$  and are stored in a queue. Messages are processed and removed from the queue at rate  $\mu$ . The average length of the queue is given by  $x \in \mathbb{R}$ .

These equations describe the motion of the vehicle as a set of three coupled second-order differential equations.  $\nabla$

### Information Systems

Information systems range from communication systems like the Internet to software systems that manipulate data or manage enterprise-wide resources. Feedback is present in all these systems, and designing strategies for routing, flow control and buffer management is a typical problem. Many results in queuing theory emerged from design of telecommunication systems and later from development of the Internet and computer communication systems [BG87, Kle75, Sch87]. Management of queues to avoid congestion is a central problem and we will therefore start by discussing the modeling of queuing systems.

#### Example 3.12 Queuing systems

A schematic picture of a simple queue is shown in Figure 3.19. Requests arrive and are then queued and processed. There can be large variations in arrival rates and service rates, and the queue length builds up when the arrival rate is larger than the service rate. When the queue becomes too large, service is denied using an admission control policy.

The system can be modeled in many different ways. One way is to model each incoming request, which leads to an event-based model where the state is an integer that represents the queue length. The queue changes when a request arrives or a request is serviced. The statistics of arrival and servicing are typically modeled as random processes. In many cases it is possible to determine statistics of quantities like queue length and service time, but the computations can be quite complicated.

A significant simplification can be obtained by approximating the discrete queue length by a continuous variable. Instead of keeping track of each request we instead view service and requests as continuous flows. The model obtained is called a *flow model* because of the analogy with fluid dynamics where motion of molecules are replaced by continuous flows. Hence, if the queue length  $x$  is a continuous variable and the arrivals and services are flows with rates  $\lambda$  and  $\mu$ , the system can be modeled by the first-order differential equation

$$\frac{dx}{dt} = \lambda - \mu = \lambda - \mu_{\max} f(x), \quad x \geq 0, \quad (3.31)$$

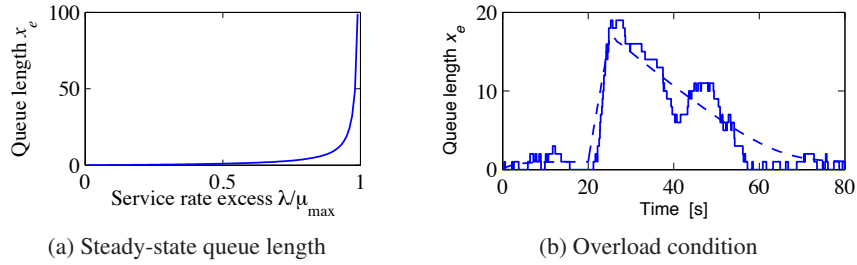

**Figure 3.20:** Queuing dynamics. (a) The steady-state queue length as a function of  $\lambda/\mu_{\max}$ . (b) The behavior of the queue length when there is a temporary overload in the system. The solid line shows a realization of an event-based simulation, and the dashed line shows the behavior of the flow model (3.32). The maximum service rate is  $\mu_{\max} = 1$ , and the arrival rate starts at  $\lambda = 0.5$ . The arrival rate is increased to  $\lambda = 4$  at time 20, and it returns to  $\lambda = 0.5$  at time 25.

proposed by Agnew [Agn76]. The service rate  $\mu$  depends on the queue length; if there are no capacity restrictions we have  $\mu = x/T$  where  $T$  is the time it takes to serve one customer. The service rate thus increases linearly with the queue length. In reality the growth will be slower because longer queues require more resources, and the service rate has an upper limit  $\mu_{\max}$ . These effects are captured by modeling the service rate as  $\mu_{\max}f(x)$  in equation (3.32). The function  $f(x)$  is monotone, approximately linear for small  $x$  and  $f(\infty) = 1$ .

For a particular queue, the function can be determined empirically by measuring the queue length for different arrival and service rates. A simple choice is  $f(x) = x/(1+x)$ , which gives the model

$$\frac{dx}{dt} = \lambda - \mu_{\max} \frac{x}{x+1}. \quad (3.32)$$

It was shown by Tipper [TS90], that if arrival and service processes are Poisson processes, then average queue length is given by equation (3.32). Furthermore the equation (3.32) is a good approximation even for short queue lengths.

To explore the properties of the model (3.32) we will first investigate the equilibrium value of the queue length when the arrival rate  $\lambda$  is constant. Setting the derivative  $dx/dt$  to zero in equation (3.32) and solving for  $x$ , we find that the queue length  $x$  approaches the steady-state value

$$x_e = \frac{\lambda}{\mu_{\max} - \lambda}. \quad (3.33)$$

Figure 3.20a shows the steady-state queue length as a function of  $\lambda/\mu_{\max}$ , the effective service rate excess. Notice that the queue length increases rapidly as  $\lambda$  approaches  $\mu_{\max}$ . To have a queue length less than 20 requires  $\lambda/\mu_{\max} < 0.95$ . The average time to service a request can be shown to be  $T_s = (x+1)/\mu_{\max}$ , and it increases dramatically as  $\lambda$  approaches  $\mu_{\max}$ .

Figure 3.20b illustrates the behavior of the server in a typical overload situation. The figure shows that the queue builds up quickly and clears very slowly. Since the

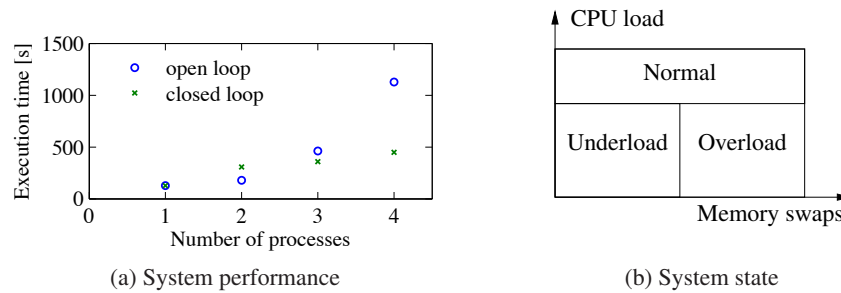

**Figure 3.21:** Illustration of feedback in the virtual memory system of the IBM/370. (a) The effect of feedback on execution times in a simulation, following [BG68]. Results with no feedback are shown with  $\circ$ , and results with feedback with  $\times$ . Notice the dramatic decrease in execution time for the system with feedback. (b) How the three states are obtained based on process measurements.

response time is proportional to queue length, it means that the quality of service is poor for a long period after an overload. This behavior is called the *rush-hour effect* and has been observed in web servers and many other queuing systems such as automobile traffic.

The dashed line in Figure 3.20b shows the behavior of the flow model, which describes the average queue length. The simple model captures behavior qualitatively, but there are variations from sample to sample when the queue length is short.  $\nabla$

Many complex systems use discrete control actions. Such systems can be modeled by characterizing the situations that correspond to each control action, as illustrated in the following example.

### Example 3.13 Virtual memory paging control

An early example of the use of feedback in computer systems was applied in the operating system OS/VS for the IBM 370 [BG68, Cro75]. The system used virtual memory, which allows programs to address more memory than is physically available as fast memory. Data in current fast memory (random access memory, RAM) is accessed directly, but data that resides in slower memory (disk) is automatically loaded into fast memory. The system is implemented in such a way that it appears to the programmer as a single large section of memory. The system performed very well in many situations, but very long execution times were encountered in overload situations, as shown by the open circles in Figure 3.21a. The difficulty was resolved with a simple discrete feedback system. The load of the central processing unit (CPU) was measured together with the number of page swaps between fast memory and slow memory. The operating region was classified as being in one of three states: normal, underload or overload. The normal state is characterized by high CPU activity, the underload state is characterized by low CPU activity and few page replacements, the overload state has moderate to low CPU load but many page replacements; see Figure 3.21b. The boundaries between the regions and the time for measuring the load were determined from simulations using typ-

ical loads. The control strategy was to do nothing in the normal load condition, to exclude a process from memory in the overload condition and to allow a new process or a previously excluded process in the underload condition. The crosses in Figure 3.21a show the effectiveness of the simple feedback system in simulated loads. Similar principles are used in many other situations, e.g., in fast, on-chip cache memory.

▽

### Example 3.14 Consensus protocols in sensor networks

Sensor networks are used in a variety of applications where we want to collect and aggregate information over a region of space using multiple sensors that are connected together via a communications network. Examples include monitoring environmental conditions in a geographical area (or inside a building), monitoring the movement of animals or vehicles and monitoring the resource loading across a group of computers. In many sensor networks the computational resources are distributed along with the sensors, and it can be important for the set of distributed agents to reach a consensus about a certain property, such as the average temperature in a region or the average computational load among a set of computers.

To illustrate how such a consensus might be achieved, we consider the problem of computing the average value of a set of numbers that are locally available to the individual agents. We wish to design a “protocol” (algorithm) such that all agents will agree on the average value. We consider the case in which all agents cannot necessarily communicate with each other directly, although we will assume that the communications network is connected (meaning that no two groups of agents are completely isolated from each other). Figure 3.22a shows a simple situation of this type.

We model the connectivity of the sensor network using a graph, with nodes corresponding to the sensors and edges corresponding to the existence of a direct communications link between two nodes. For any such graph, we can build an *adjacency matrix*, where each row and column of the matrix corresponds to a node and a 1 in the respective row and column indicates that the two nodes are connected. For the network shown in Figure 3.22a, the corresponding adjacency matrix is

$$A = \begin{pmatrix} 0 & 1 & 0 & 0 & 0 \\ 1 & 0 & 1 & 1 & 1 \\ 0 & 1 & 0 & 1 & 0 \\ 0 & 1 & 1 & 0 & 0 \\ 0 & 1 & 0 & 0 & 0 \end{pmatrix}.$$

We use the notation  $\mathcal{N}_i$  to represent the set of neighbors of a node  $i$ . For example, in the network shown in Figure 3.22a  $\mathcal{N}_2 = \{1, 3, 4, 5\}$  and  $\mathcal{N}_3 = \{2, 4\}$ .

To solve the consensus problem, let  $x_i$  be the state of the  $i$ th sensor, corresponding to that sensor’s estimate of the average value that we are trying to compute. We initialize the state to the value of the quantity measured by the individual sensor.

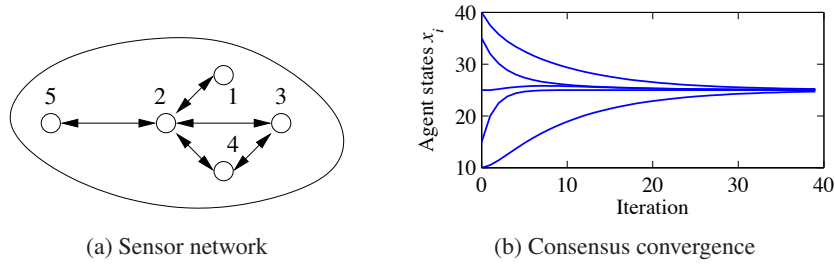

**Figure 3.22:** Consensus protocols for sensor networks. (a) A simple sensor network with five nodes. In this network, node 1 communicates with node 2 and node 2 communicates with nodes 1, 3, 4, 5, etc. (b) A simulation demonstrating the convergence of the consensus protocol (3.34) to the average value of the initial conditions.

The consensus protocol (algorithm) can now be realized as a local update law

$$x_i[k+1] = x_i[k] + \gamma \sum_{j \in \mathcal{N}_i} (x_j[k] - x_i[k]). \quad (3.34)$$

This protocol attempts to compute the average by updating the local state of each agent based on the value of its neighbors. The combined dynamics of all agents can be written in the form

$$x[k+1] = x[k] - \gamma(D - A)x[k], \quad (3.35)$$

where  $A$  is the adjacency matrix and  $D$  is a diagonal matrix with entries corresponding to the number of neighbors of each node. The constant  $\gamma$  describes the rate at which the estimate of the average is updated based on information from neighboring nodes. The matrix  $L := D - A$  is called the *Laplacian* of the graph.

The equilibrium points of equation (3.35) are the set of states such that  $x_e[k+1] = x_e[k]$ . It can be shown that if the network is connected,  $x_e = (\alpha, \alpha, \dots, \alpha)$  is an equilibrium state for the system, corresponding to each sensor having an identical estimate  $\alpha$  for the average. Furthermore, we can show that  $\alpha$  is indeed the average value of the initial states. Since there can be cycles in the graph, it is possible that the state of the system could enter into an infinite loop and never converge to the desired consensus state. A formal analysis requires tools that will be introduced later in the text, but it can be shown that for any connected graph we can always find a  $\gamma$  such that the states of the individual agents converge to the average. A simulation demonstrating this property is shown in Figure 3.22b. Although we have focused here on consensus to the average value of a set of measurements, other consensus states can be achieved through choice of appropriate feedback laws. Examples include finding the maximum or minimum value in a network, counting the number of nodes in a network or computing higher-order statistical moments of a distributed quantity [OSFM07].  $\nabla$

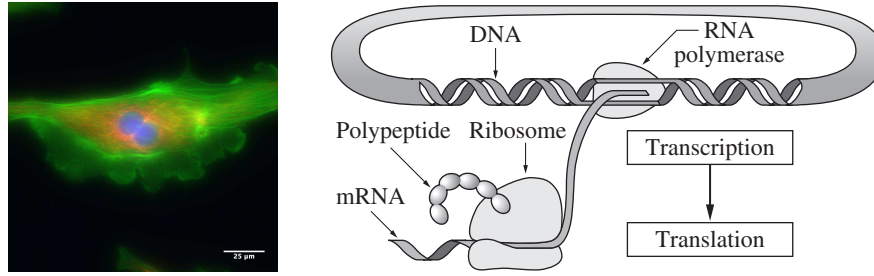

**Figure 3.23:** Biological circuitry. The cell on the left is a bovine pulmonary cell, stained so that the nucleus, actin and chromatin are visible. The figure on the right gives an overview of the process by which proteins in the cell are made. RNA is transcribed from DNA by an RNA polymerase enzyme. The RNA is then translated into a polypeptide chain by a molecular machine called a ribosome, and then the polypeptide chain folds into a protein molecule.

### Biological Systems

Biological systems provide perhaps the richest source of feedback and control examples. The basic problem of homeostasis, in which a quantity such as temperature or blood sugar level is regulated to a fixed value, is but one of the many types of complex feedback interactions that can occur in molecular machines, cells, organisms and ecosystems.

#### Example 3.15 Transcriptional regulation

Transcription is the process by which messenger RNA (mRNA) is generated from a segment of DNA. The promoter region of a gene allows transcription to be controlled by the presence of other proteins, called *transcription factors*, which bind to the promoter region and either repress or activate RNA polymerase, the enzyme that produces an mRNA transcript from DNA. The mRNA is then translated into a protein according to its nucleotide sequence. This process is illustrated in Figure 3.23.

A simple model of the transcriptional regulation process is through the use of a Hill function [dJ02, Mur04]. Consider the regulation of a protein A with a concentration given by  $p_a$  and a corresponding mRNA concentration  $m_a$ . Let B be a second protein with concentration  $p_b$  that represses the production of protein A through transcriptional regulation. The resulting dynamics of  $p_a$  and  $m_a$  can be written as

$$\frac{dm_a}{dt} = \frac{\alpha_{ab}}{1 + k_{ab}p_b^{n_{ab}}} + \alpha_{a0} - \gamma_a m_a, \quad \frac{dp_a}{dt} = \beta_a m_a - \delta_a p_a, \quad (3.36)$$

where  $\alpha_{ab} + \alpha_{a0}$  is the unregulated transcription rate,  $\gamma_a$  represents the rate of degradation of mRNA,  $\alpha_{ab}$ ,  $k_{ab}$  and  $n_{ab}$  are parameters that describe how B represses A,  $\beta_a$  represents the rate of production of the protein from its corresponding mRNA and  $\delta_a$  represents the rate of degradation of the protein A. The parameter  $\alpha_{a0}$  describes the “leakiness” of the promoter, and  $n_{ab}$  is called the Hill coefficient and relates to the cooperativity of the promoter.



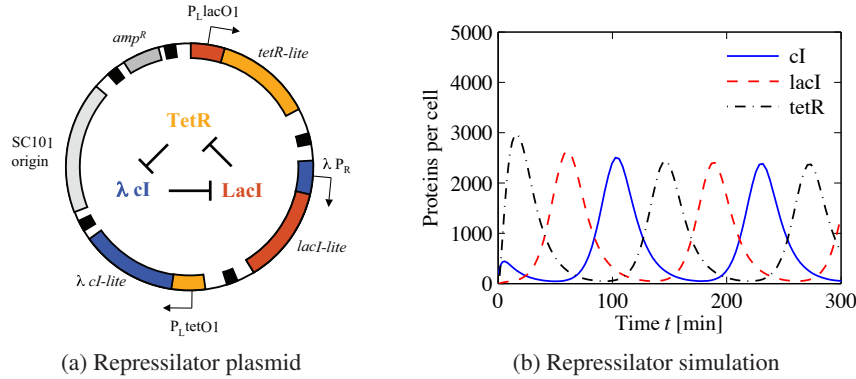

**Figure 3.24:** The repressilator genetic regulatory network. (a) A schematic diagram of the repressilator, showing the layout of the genes in the plasmid that holds the circuit as well as the circuit diagram (center). (b) A simulation of a simple model for the repressilator, showing the oscillation of the individual protein concentrations. (Figure courtesy M. Elowitz.)

A similar model can be used when a protein activates the production of another protein rather than repressing it. In this case, the equations have the form

$$\frac{dm_a}{dt} = \frac{\alpha_{ab}k_{ab}p_b^{n_{ab}}}{1 + k_{ab}p_b^{n_{ab}}} + \alpha_{a0} - \gamma_a m_a, \quad \frac{dp_a}{dt} = \beta_a m_a - \delta_a p_a, \quad (3.37)$$

where the variables are the same as described previously. Note that in the case of the activator, if  $p_b$  is zero, then the production rate is  $\alpha_{a0} \ll \alpha_{ab}$  (versus  $\alpha_{ab} + \alpha_{a0}$  for the repressor). As  $p_b$  gets large, the first term in the expression for  $\dot{m}_a$  approaches 1 and the transcription rate becomes  $\alpha_{ab} + \alpha_{a0}$  (versus  $\alpha_{a0}$  for the repressor). Thus we see that the activator and repressor act in opposite fashion from each other.

As an example of how these models can be used, we consider the model of a “repressilator,” originally due to Elowitz and Leibler [EL00]. The repressilator is a synthetic circuit in which three proteins each repress another in a cycle. This is shown schematically in Figure 3.24a, where the three proteins are TetR,  $\lambda$  cI and LacI. The basic idea of the repressilator is that if TetR is present, then it represses the production of  $\lambda$  cI. If  $\lambda$  cI is absent, then LacI is produced (at the unregulated transcription rate), which in turn represses TetR. Once TetR is repressed, then  $\lambda$  cI is no longer repressed, and so on. If the dynamics of the circuit are designed properly, the resulting protein concentrations will oscillate.

We can model this system using three copies of equation (3.36), with A and B replaced by the appropriate combination of TetR, cI and LacI. The state of the system is then given by  $x = (m_{\text{TetR}}, p_{\text{TetR}}, m_{\text{cI}}, p_{\text{cI}}, m_{\text{LacI}}, p_{\text{LacI}})$ . Figure 3.24b shows the traces of the three protein concentrations for parameters  $n = 2$ ,  $\alpha = 0.5$ ,  $k = 6.25 \times 10^{-4}$ ,  $\alpha_0 = 5 \times 10^{-4}$ ,  $\gamma = 5.8 \times 10^{-3}$ ,  $\beta = 0.12$  and  $\delta = 1.2 \times 10^{-3}$  with initial conditions  $x(0) = (1, 0, 0, 200, 0, 0)$  (following [EL00]).  $\nabla$

### Example 3.16 Wave propagation in neuronal networks

The dynamics of the membrane potential in a cell are a fundamental mechanism in understanding signaling in cells, particularly in neurons and muscle cells. The Hodgkin–Huxley equations give a simple model for studying propagation waves in networks of neurons. The model for a single neuron has the form

$$C \frac{dV}{dt} = -I_{\text{Na}} - I_{\text{K}} - I_{\text{leak}} + I_{\text{input}},$$

where  $V$  is the membrane potential,  $C$  is the capacitance,  $I_{\text{Na}}$  and  $I_{\text{K}}$  are the current caused by the transport of sodium and potassium across the cell membrane,  $I_{\text{leak}}$  is a leakage current and  $I_{\text{input}}$  is the external stimulation of the cell. Each current obeys Ohm’s law, i.e.,

$$I = g(V - E),$$

where  $g$  is the conductance, which is different for different ions, and  $E$  is the equilibrium voltage. The equilibrium voltage is given by Nernst’s law,

$$E = \frac{RT}{nF} \log \frac{c_e}{c_i},$$

where  $R$  is Boltzmann’s constant,  $T$  is the absolute temperature,  $F$  is Faraday’s constant,  $n$  is the charge (or valence) of the ion and  $c_i$  and  $c_e$  are the ion concentrations inside the cell and in the external fluid. At 20 °C we have  $RT/F = 20$  mV.

The Hodgkin–Huxley model was originally developed as a means to predict the quantitative behavior of the squid giant axon [HH52]. Hodgkin and Huxley shared the 1963 Nobel Prize in Physiology (along with J. C. Eccles) for analysis of the electrical and chemical events in nerve cell discharges. The voltage clamp described in Section 1.3 was a key element in Hodgkin and Huxley’s experiments.

▽

### 3.5 Further Reading

Modeling is ubiquitous in engineering and science and has a long history in applied mathematics. For example, the Fourier series was introduced by Fourier when he modeled heat conduction in solids [Fou07]. Models of dynamics have been developed in many different fields, including mechanics [Arn78, Gol53], heat conduction [CJ59], fluids [BRS60], vehicles [Abk69, Bla91, Ell94], robotics [MLS94, SV89], circuits [Gui63], power systems [Kun93], acoustics [Ber54] and micromechanical systems [Sen01]. Control theory requires modeling from many different domains, and most control theory texts contain several chapters on modeling using ordinary differential equations and difference equations (see, for example, [FPEN05]). A classic book on the modeling of physical systems, especially mechanical, electrical and thermofluid systems, is Cannon [Can03]. The book by Aris [Ari94] is highly original and has a detailed discussion of the use of dimension-free variables. Two of the authors’ favorite books on modeling of biological systems are J. D. Murray [Mur04] and Wilson [Wil99]. A good source for system identification in Ljung [Lju99].

## Exercises

**3.1** (Chain of integrators form) Consider the linear ordinary differential equation (3.7). Show that by choosing a state space representation with  $x_1 = y$ , the dynamics can be written as

$$A = \begin{pmatrix} 0 & 1 & & 0 \\ 0 & \ddots & \ddots & 0 \\ 0 & \cdots & 0 & 1 \\ -a_n & -a_{n-1} & & -a_1 \end{pmatrix}, \quad B = \begin{pmatrix} 0 \\ 0 \\ \vdots \\ 1 \end{pmatrix}, \quad C = \begin{pmatrix} 1 & \cdots & 0 & 0 \end{pmatrix}.$$

This canonical form is called the *chain of integrators* form.

**3.2** (Inverted pendulum) Use the equations of motion for a balance system to derive a dynamic model for the inverted pendulum described in Example 3.2 and verify that the dynamics are given by equation (3.10).

**3.3** (Discrete-time dynamics) Consider the following discrete-time system

$$x[k+1] = Ax[k] + Bu[k], \quad y[k] = Cx[k],$$

where

$$x = \begin{pmatrix} x_1 \\ x_2 \end{pmatrix}, \quad A = \begin{pmatrix} a_{11} & a_{12} \\ 0 & a_{22} \end{pmatrix}, \quad B = \begin{pmatrix} 0 \\ 1 \end{pmatrix}, \quad C = \begin{pmatrix} 1 & 0 \end{pmatrix}.$$

In this problem, we will explore some of the properties of this discrete-time system as a function of the parameters, the initial conditions and the inputs.

(a) For the case when  $a_{12} = 0$  and  $u = 0$ , give a closed form expression for the output of the system.

(b) A discrete system is in *equilibrium* when  $x[k+1] = x[k]$  for all  $k$ . Let  $u = r$  be a constant input and compute the resulting equilibrium point for the system. Show that if  $|a_{ii}| < 1$  for all  $i$ , all initial conditions give solutions that converge to the equilibrium point.

(c) Write a computer program to plot the output of the system in response to a unit step input,  $u[k] = 1, k \geq 0$ . Plot the response of your system with  $x[0] = 0$  and  $A$  given by  $a_{11} = 0.5, a_{12} = 1$  and  $a_{22} = 0.25$ .

**3.4** (Keynesian economics) Keynes' simple model for an economy is given by

$$Y[k] = C[k] + I[k] + G[k],$$

where  $Y, C, I$  and  $G$  are gross national product (GNP), consumption, investment and government expenditure for year  $k$ . Consumption and investment are modeled by difference equations of the form

$$C[k+1] = aY[k], \quad I[k+1] = b(C[k+1] - C[k]),$$

where  $a$  and  $b$  are parameters. The first equation implies that consumption increases with GNP but that the effect is delayed. The second equation implies that investment is proportional to the rate of change of consumption.

Show that the equilibrium value of the GNP is given by

$$Y_e = \frac{1}{1-a} G_e,$$

where the parameter  $1/(1-a)$  is the Keynes multiplier (the gain from  $G$  to  $Y$ ). With  $a = 0.75$  an increase of government expenditure will result in a fourfold increase of GNP. Also show that the model can be written as the following discrete-time state model:

$$\begin{aligned} \begin{pmatrix} C[k+1] \\ I[k+1] \end{pmatrix} &= \begin{pmatrix} a & a \\ ab-b & ab \end{pmatrix} \begin{pmatrix} C[k] \\ I[k] \end{pmatrix} + \begin{pmatrix} a \\ ab \end{pmatrix} G[k], \\ Y[k] &= C[k] + I[k] + G[k]. \end{aligned}$$



**3.5** (Least squares system identification) Consider a nonlinear differential equation that can be written in the form

$$\frac{dx}{dt} = \sum_{i=1}^M \alpha_i f_i(x),$$

where  $f_i(x)$  are known nonlinear functions and  $\alpha_i$  are unknown, but constant, parameters. Suppose that we have measurements (or estimates) of the full state  $x$  at time instants  $t_1, t_2, \dots, t_N$ , with  $N > M$ . Show that the parameters  $\alpha_i$  can be estimated by finding the least squares solution to a linear equation of the form

$$H\alpha = b,$$

where  $\alpha \in \mathbb{R}^M$  is the vector of all parameters and  $H \in \mathbb{R}^{N \times M}$  and  $b \in \mathbb{R}^N$  are appropriately defined.

**3.6** (Normalized oscillator dynamics) Consider a damped spring–mass system with dynamics

$$m\ddot{q} + c\dot{q} + kq = F.$$

Let  $\omega_0 = \sqrt{k/m}$  be the natural frequency and  $\zeta = c/(2\sqrt{km})$  be the damping ratio.

(a) Show that by rescaling the equations, we can write the dynamics in the form

$$\ddot{q} + 2\zeta\omega_0\dot{q} + \omega_0^2q = \omega_0^2u, \quad (3.38)$$

where  $u = F/k$ . This form of the dynamics is that of a linear oscillator with natural frequency  $\omega_0$  and damping ratio  $\zeta$ .

(b) Show that the system can be further normalized and written in the form

$$\frac{dz_1}{d\tau} = z_2, \quad \frac{dz_2}{d\tau} = -z_1 - 2\zeta z_2 + v. \quad (3.39)$$

The essential dynamics of the system are governed by a single damping parameter  $\zeta$ . The  $Q$ -value defined as  $Q = 1/2\zeta$  is sometimes used instead of  $\zeta$ .

**3.7** (Electric generator) An electric generator connected to a strong power grid can be modeled by a momentum balance for the rotor of the generator:

$$J \frac{d^2 \varphi}{dt^2} = P_m - P_e = P_m - \frac{EV}{X} \sin \varphi,$$

where  $J$  is the effective moment of inertia of the generator,  $\varphi$  the angle of rotation,  $P_m$  the mechanical power that drives the generator,  $P_e$  is the active electrical power,  $E$  the generator voltage,  $V$  the grid voltage and  $X$  the reactance of the line. Assuming that the line dynamics are much faster than the rotor dynamics,  $P_e = VI = (EV/X) \sin \varphi$ , where  $I$  is the current component in phase with the voltage  $E$  and  $\varphi$  is the phase angle between voltages  $E$  and  $V$ . Show that the dynamics of the electric generator has a normalized form that is similar to the dynamics of a pendulum with forcing at the pivot.

**3.8** (Admission control for a queue) Consider the queuing system described in Example 3.12. The long delays created by temporary overloads can be reduced by rejecting requests when the queue gets large. This allows requests that are accepted to be serviced quickly and requests that cannot be accommodated to receive a rejection quickly so that they can try another server. Consider an admission control system described by

$$\frac{dx}{dt} = \lambda u - \mu_{\max} \frac{x}{x+1}, \quad u = \text{sat}_{(0,1)}(k(r-x)), \quad (3.40)$$

where the controller is a simple proportional control with saturation ( $\text{sat}_{(a,b)}$  is defined by equation (4.9)) and  $r$  is the desired (reference) queue length. Use a simulation to show that this controller reduces the rush-hour effect and explain how the choice of  $r$  affects the system dynamics.

**3.9** (Biological switch) A genetic switch can be formed by connecting two repressors together in a cycle as shown below.

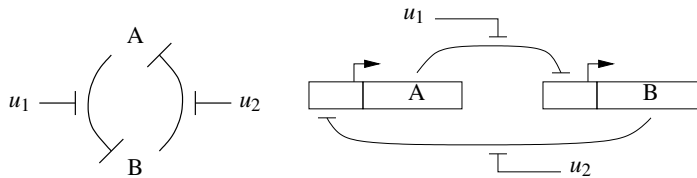

Using the models from Example 3.15—assuming that the parameters are the same for both genes and that the mRNA concentrations reach steady state quickly—show that the dynamics can be written in normalized coordinates as

$$\frac{dz_1}{d\tau} = \frac{\mu}{1+z_2^n} - z_1 - v_1, \quad \frac{dz_2}{d\tau} = \frac{\mu}{1+z_1^n} - z_2 - v_2, \quad (3.41)$$

where  $z_1$  and  $z_2$  are scaled versions of the protein concentrations and the time scale has also been changed. Show that  $\mu \approx 200$  using the parameters in Example 3.15, and use simulations to demonstrate the switch-like behavior of the system.

**3.10 (Motor drive)** Consider a system consisting of a motor driving two masses that are connected by a torsional spring, as shown in the diagram below.

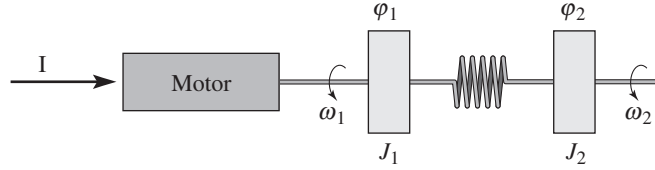

This system can represent a motor with a flexible shaft that drives a load. Assuming that the motor delivers a torque that is proportional to the current  $I$ , the dynamics of the system can be described by the equations

$$\begin{aligned} J_1 \frac{d^2 \varphi_1}{dt^2} + c \left( \frac{d\varphi_1}{dt} - \frac{d\varphi_2}{dt} \right) + k(\varphi_1 - \varphi_2) &= k_I I, \\ J_2 \frac{d^2 \varphi_2}{dt^2} + c \left( \frac{d\varphi_2}{dt} - \frac{d\varphi_1}{dt} \right) + k(\varphi_2 - \varphi_1) &= T_d, \end{aligned} \quad (3.42)$$

where  $\varphi_1$  and  $\varphi_2$  are the angles of the two masses,  $\omega_i = d\varphi_i/dt$  are their velocities,  $J_i$  represents moments of inertia,  $c$  is the damping coefficient,  $k$  represents the shaft stiffness,  $k_I$  is the torque constant for the motor, and  $T_d$  is the disturbance torque applied at the end of the shaft. Similar equations are obtained for a robot with flexible arms and for the arms of DVD and optical disk drives.

Derive a state space model for the system by introducing the (normalized) state variables  $x_1 = \varphi_1$ ,  $x_2 = \varphi_2$ ,  $x_3 = \omega_1/\omega_0$ , and  $x_4 = \omega_2/\omega_0$ , where  $\omega_0 = \sqrt{k(J_1 + J_2)/(J_1 J_2)}$  is the undamped natural frequency of the system when the control signal is zero.

---

## Chapter Four

### Examples

*... Don't apply any model until you understand the simplifying assumptions on which it is based, and you can test their validity. Catch phrase: use only as directed. Don't limit yourself to a single model: More than one model may be useful for understanding different aspects of the same phenomenon. Catch phrase: legalize polygamy."*

Saul Golomb, "Mathematical Models—Uses and Limitations," 1970 [Gol70].

In this chapter we present a collection of examples spanning many different fields of science and engineering. These examples are used throughout the text and in exercises to illustrate different concepts.

#### 4.1 Cruise Control

The cruise control system of a car is a common feedback system encountered in everyday life. The system attempts to maintain a constant velocity in the presence of disturbances primarily caused by changes in the slope of a road. The controller compensates for these unknowns by measuring the speed of the car and adjusting the throttle appropriately.

To model the system we start with the block diagram in Figure 4.1. Let  $v$  be the speed of the car and  $v_r$  the desired (reference) speed. The controller, which typically is of the proportional-integral (PI) type described briefly in Chapter 1, receives the signals  $v$  and  $v_r$  and generates a control signal  $u$  that is sent to an actuator that controls the throttle position. The throttle in turn controls the torque  $T$  delivered by the engine, which is transmitted through the gears and the wheels, generating a force  $F$  that moves the car. There are disturbance forces  $F_d$  due to variations in the slope of the road, the rolling resistance and aerodynamic forces. The cruise controller also has a human-machine interface that allows the driver to set and modify the desired speed. There are also functions that disconnect the cruise control when the brake is touched.

The system has many individual components—actuator, engine, transmission, wheels and car body—and a detailed model can be very complicated. In spite of this, the model required to design the cruise controller can be quite simple.

To develop a mathematical model we start with a force balance for the car body. Let  $v$  be the speed of the car,  $m$  the total mass (including passengers),  $F$  the force generated by the contact of the wheels with the road, and  $F_d$  the disturbance force due to gravity, friction and aerodynamic drag. The equation of motion of the car is

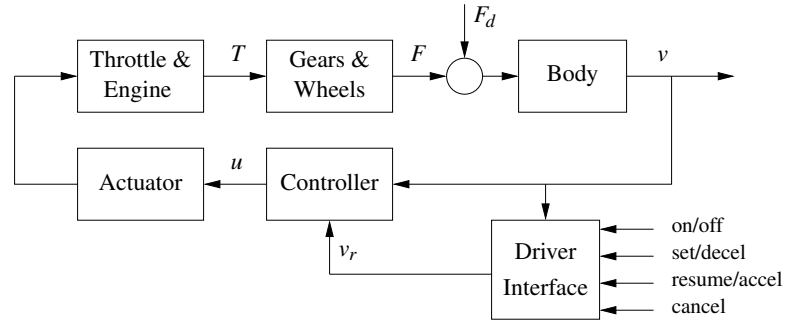

**Figure 4.1:** Block diagram of a cruise control system for an automobile. The throttle-controlled engine generates a torque  $T$  that is transmitted to the ground through the gearbox and wheels. Combined with the external forces from the environment, such as aerodynamic drag and gravitational forces on hills, the net force causes the car to move. The velocity of the car  $v$  is measured by a control system that adjusts the throttle through an actuation mechanism. A driver interface allows the system to be turned on and off and the reference speed  $v_r$  to be established.

simply

$$m \frac{dv}{dt} = F - F_d. \quad (4.1)$$

The force  $F$  is generated by the engine, whose torque is proportional to the rate of fuel injection, which is itself proportional to a control signal  $0 \leq u \leq 1$  that controls the throttle position. The torque also depends on engine speed  $\omega$ . A simple representation of the torque at full throttle is given by the torque curve

$$T(\omega) = T_m \left( 1 - \beta \left( \frac{\omega}{\omega_m} - 1 \right)^2 \right), \quad (4.2)$$

where the maximum torque  $T_m$  is obtained at engine speed  $\omega_m$ . Typical parameters are  $T_m = 190$  Nm,  $\omega_m = 420$  rad/s (about 4000 RPM) and  $\beta = 0.4$ . Let  $n$  be the gear

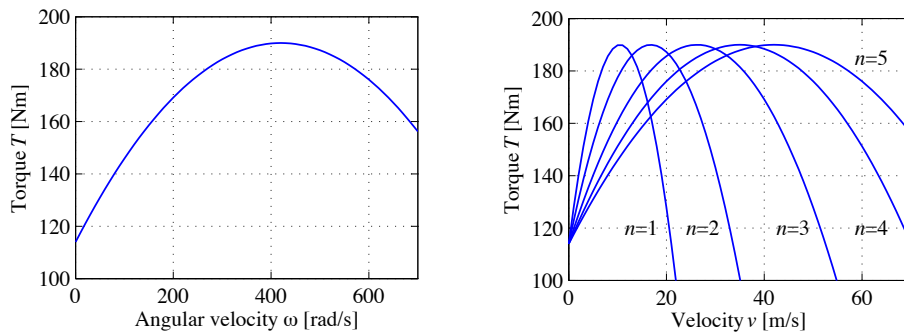

**Figure 4.2:** Torque curves for typical car engine. The graph on the left shows the torque generated by the engine as a function of the angular velocity of the engine, while the curve on the right shows torque as a function of car speed for different gears.



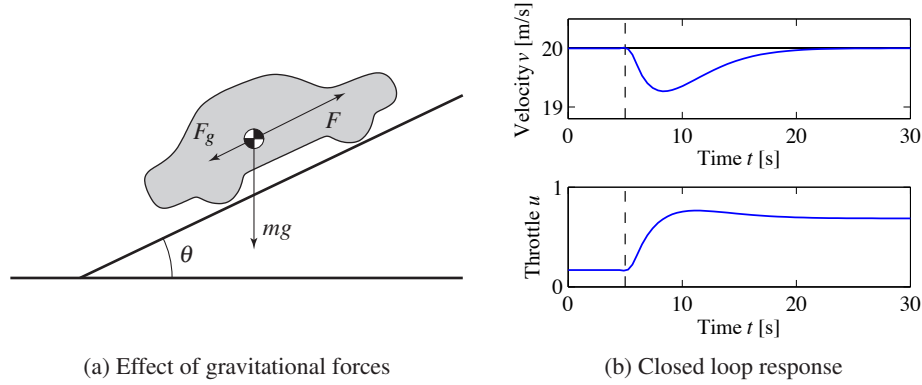

**Figure 4.3:** Car with cruise control encountering a sloping road. A schematic diagram is shown in (a), and (b) shows the response in speed and throttle when a slope of  $4^\circ$  is encountered. The hill is modeled as a net change of  $4^\circ$  in hill angle  $\theta$ , with a linear change in the angle between  $t = 5$  and  $t = 6$ . The PI controller has proportional gain is  $k_p = 0.5$ , and the integral gain is  $k_i = 0.1$ .

ratio and  $r$  the wheel radius. The engine speed is related to the velocity through the expression

$$\omega = \frac{n}{r}v =: \alpha_n v,$$

and the driving force can be written as

$$F = \frac{nu}{r}T(\omega) = \alpha_n u T(\alpha_n v).$$

Typical values of  $\alpha_n$  for gears 1 through 5 are  $\alpha_1 = 40$ ,  $\alpha_2 = 25$ ,  $\alpha_3 = 16$ ,  $\alpha_4 = 12$  and  $\alpha_5 = 10$ . The inverse of  $\alpha_n$  has a physical interpretation as the *effective wheel radius*. Figure 4.2 shows the torque as a function of engine speed and vehicle speed. The figure shows that the effect of the gear is to “flatten” the torque curve so that an almost full torque can be obtained almost over the whole speed range.

The disturbance force  $F_d$  has three major components:  $F_g$ , the forces due to gravity;  $F_r$ , the forces due to rolling friction; and  $F_a$ , the aerodynamic drag. Letting the slope of the road be  $\theta$ , gravity gives the force  $F_g = mg \sin \theta$ , as illustrated in Figure 4.3a, where  $g = 9.8 \text{ m/s}^2$  is the gravitational constant. A simple model of rolling friction is

$$F_r = mgC_r \text{sgn}(v),$$

where  $C_r$  is the coefficient of rolling friction and  $\text{sgn}(v)$  is the sign of  $v$  ( $\pm 1$ ) or zero if  $v = 0$ . A typical value for the coefficient of rolling friction is  $C_r = 0.01$ . Finally, the aerodynamic drag is proportional to the square of the speed:

$$F_a = \frac{1}{2}\rho C_d A |v|v,$$

where  $\rho$  is the density of air,  $C_d$  is the shape-dependent aerodynamic drag coefficient and  $A$  is the frontal area of the car. Typical parameters are  $\rho = 1.3 \text{ kg/m}^3$ ,

$C_d = 0.32$  and  $A = 2.4 \text{ m}^2$ .

Summarizing, we find that the car can be modeled by

$$m \frac{dv}{dt} = \alpha_n u T(\alpha_n v) - mg C_r \text{sgn}(v) - \frac{1}{2} \rho C_d A v^2 - mg \sin \theta, \quad (4.3)$$

where the function  $T$  is given by equation (4.2). The model (4.3) is a dynamical system of first order. The state is the car velocity  $v$ , which is also the output. The input is the signal  $u$  that controls the throttle position, and the disturbance is the force  $F_d$ , which depends on the slope of the road. The system is nonlinear because of the torque curve, the gravity term and the nonlinear character of rolling friction and aerodynamic drag. There can also be variations in the parameters; e.g., the mass of the car depends on the number of passengers and the load being carried in the car.

We add to this model a feedback controller that attempts to regulate the speed of the car in the presence of disturbances. We shall use a proportional-integral controller, which has the form

$$u(t) = k_p e(t) + k_i \int_0^t e(\tau) d\tau.$$

This controller can itself be realized as an input/output dynamical system by defining a controller state  $z$  and implementing the differential equation

$$\frac{dz}{dt} = v_r - v, \quad u = k_p (v_r - v) + k_i z, \quad (4.4)$$

where  $v_r$  is the desired (reference) speed. As discussed briefly in Section 1.5, the integrator (represented by the state  $z$ ) ensures that in steady state the error will be driven to zero, even when there are disturbances or modeling errors. (The design of PI controllers is the subject of Chapter 11.) Figure 4.3b shows the response of the closed loop system, consisting of equations (4.3) and (4.4), when it encounters a hill. The figure shows that even if the hill is so steep that the throttle changes from 0.17 to almost full throttle, the largest speed error is less than 1 m/s, and the desired velocity is recovered after 20 s.

Many approximations were made when deriving the model (4.3). It may seem surprising that such a seemingly complicated system can be described by the simple model (4.3). It is important to make sure that we restrict our use of the model to the uncertainty lemon conceptualized in Figure 3.5b. The model is not valid for very rapid changes of the throttle because we have ignored the details of the engine dynamics, neither is it valid for very slow changes because the properties of the engine will change over the years. Nevertheless the model is very useful for the design of a cruise control system. As we shall see in later chapters, the reason for this is the inherent robustness of feedback systems: even if the model is not perfectly accurate, we can use it to design a controller and make use of the feedback in the controller to manage the uncertainty in the system.

The cruise control system also has a human-machine interface that allows the driver to communicate with the system. There are many different ways to imple-

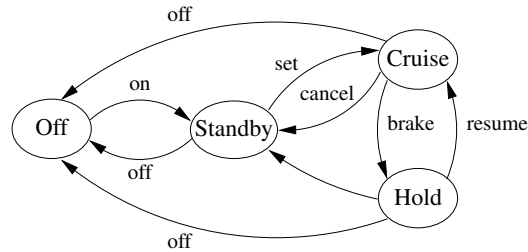

**Figure 4.4:** Finite state machine for cruise control system. The figure on the left shows some typical buttons used to control the system. The controller can be in one of four modes, corresponding to the nodes in the diagram on the right. Transition between the modes is controlled by pressing one of the five buttons on the cruise control interface: on, off, set, resume or cancel.

ment this system; one version is illustrated in Figure 4.4. The system has four buttons: on-off, set/decelerate, resume/accelerate and cancel. The operation of the system is governed by a finite state machine that controls the modes of the PI controller and the reference generator. Implementation of controllers and reference generators will be discussed more fully in Chapter 11.

The use of control in automotive systems goes well beyond the simple cruise control system described here. Applications include emissions control, traction control, power control (especially in hybrid vehicles) and adaptive cruise control. Many automotive applications are discussed in detail in the book by Kiencke and Nielsen [KN00] and in the survey papers by Powers et al. [BP96, PN00].

## 4.2 Bicycle Dynamics

The bicycle is an interesting dynamical system with the feature that one of its key properties is due to a feedback mechanism that is created by the design of the front fork. A detailed model of a bicycle is complex because the system has many degrees of freedom and the geometry is complicated. However, a great deal of insight can be obtained from simple models.

To derive the equations of motion we assume that the bicycle rolls on the horizontal  $xy$  plane. Introduce a coordinate system that is fixed to the bicycle with the  $\xi$ -axis through the contact points of the wheels with the ground, the  $\eta$ -axis horizontal and the  $\zeta$ -axis vertical, as shown in Figure 4.5. Let  $v_0$  be the velocity of the bicycle at the rear wheel,  $b$  the wheel base,  $\varphi$  the tilt angle and  $\delta$  the steering angle. The coordinate system rotates around the point  $O$  with the angular velocity  $\omega = v_0 \delta / b$ , and an observer fixed to the bicycle experiences forces due to the motion of the coordinate system.

The tilting motion of the bicycle is similar to an inverted pendulum, as shown in the rear view in Figure 4.5b. To model the tilt, consider the rigid body obtained when the wheels, the rider and the front fork assembly are fixed to the bicycle frame. Let  $m$  be the total mass of the system,  $J$  the moment of inertia of this body

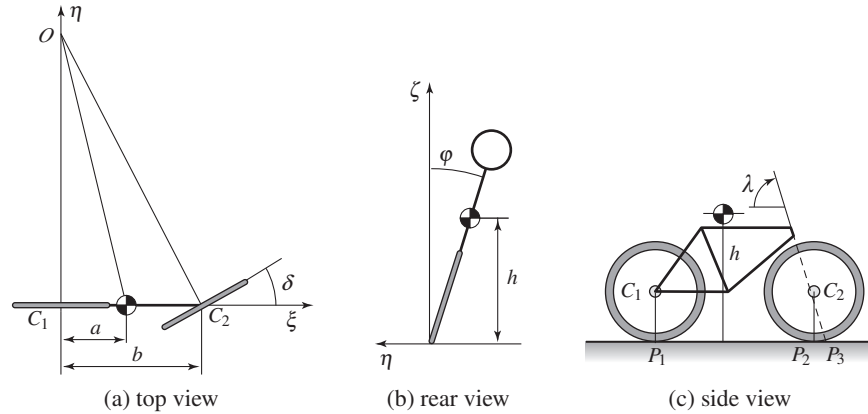

**Figure 4.5:** Schematic views of a bicycle. The steering angle is  $\delta$ , and the roll angle is  $\varphi$ . The center of mass has height  $h$  and distance  $a$  from a vertical through the contact point  $P_1$  of the rear wheel. The wheel base  $b$  is the distance between  $P_1$  and  $P_2$ , and the trail  $c$  is the distance between  $P_2$  and  $P_3$ .

with respect to the  $\xi$ -axis and  $D$  the product of inertia with respect to the  $\xi\zeta$  axes. Furthermore, let the  $\xi$  and  $\zeta$  coordinates of the center of mass with respect to the rear wheel contact point,  $P_1$ , be  $a$  and  $h$ , respectively. We have  $J \approx mh^2$  and  $D = mah$ . The torques acting on the system are due to gravity and centripetal action. Assuming that the steering angle  $\delta$  is small, the equation of motion becomes

$$J \frac{d^2 \varphi}{dt^2} - \frac{Dv_0}{b} \frac{d\delta}{dt} = mgh \sin \varphi + \frac{mv_0^2 h}{b} \delta. \quad (4.5)$$

The term  $mgh \sin \varphi$  is the torque generated by gravity. The terms containing  $\delta$  and its derivative are the torques generated by steering, with the term  $(Dv_0/b) d\delta/dt$  due to inertial forces and the term  $(mv_0^2 h/b) \delta$  due to centripetal forces.

The steering angle is influenced by the torque the rider applies to the handle bar. Because of the tilt of the steering axis and the shape of the front fork, the contact point of the front wheel with the road  $P_2$  is behind the axis of rotation of the front wheel assembly, as shown in Figure 4.5c. The distance  $c$  between the contact point of the front wheel  $P_2$  and the projection of the axis of rotation of the front fork assembly  $P_3$  is called the *trail*. The steering properties of a bicycle depend critically on the trail. A large trail increases stability but makes the steering less agile.

A consequence of the design of the front fork is that the steering angle  $\delta$  is influenced both by steering torque  $T$  and by the tilt of the frame  $\varphi$ . This means that a bicycle with a front fork is a *feedback system* as illustrated by the block diagram in Figure 4.6. The steering angle  $\delta$  influences the tilt angle  $\varphi$ , and the tilt angle influences the steering angle, giving rise to the circular causality that is characteristic of reasoning about feedback. For a front fork with a positive trail, the bicycle will steer into the lean, creating a centrifugal force that attempts to diminish the lean. Under certain conditions, the feedback can actually stabilize the

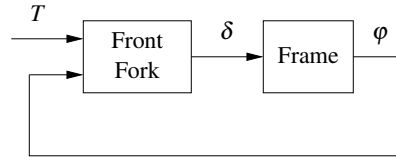

**Figure 4.6:** Block diagram of a bicycle with a front fork. The steering torque applied to the handlebars is  $T$ , the roll angle is  $\varphi$  and the steering angle is  $\delta$ . Notice that the front fork creates a feedback from the roll angle  $\varphi$  to the steering angle  $\delta$  that under certain conditions can stabilize the system.

bicycle. A crude empirical model is obtained by assuming that the block  $B$  can be modeled as the static system

$$\delta = k_1 T - k_2 \varphi. \quad (4.6)$$

This model neglects the dynamics of the front fork, the tire–road interaction and the fact that the parameters depend on the velocity. A more accurate model, called the *Whipple model*, is obtained using the rigid-body dynamics of the front fork and the frame. Assuming small angles, this model becomes

$$M \begin{pmatrix} \ddot{\varphi} \\ \ddot{\delta} \end{pmatrix} + C v_0 \begin{pmatrix} \dot{\varphi} \\ \dot{\delta} \end{pmatrix} + (K_0 + K_2 v_0^2) \begin{pmatrix} \varphi \\ \delta \end{pmatrix} = \begin{pmatrix} 0 \\ T \end{pmatrix}, \quad (4.7)$$

where the elements of the  $2 \times 2$  matrices  $M$ ,  $C$ ,  $K_0$  and  $K_2$  depend on the geometry and the mass distribution of the bicycle. Note that this has a form somewhat similar to that of the spring–mass system introduced in Chapter 3 and the balance system in Example 3.1. Even this more complex model is inaccurate because the interaction between the tire and the road is neglected; taking this into account requires two additional state variables. Again, the uncertainty lemon in Figure 3.5b provides a framework for understanding the validity of the model under these assumptions.

Interesting presentations on the development of the bicycle are given in the books by D. Wilson [Wil04] and Herlihy [Her04]. The model (4.7) was presented in a paper by Whipple in 1899 [Whi99]. More details on bicycle modeling are given in the paper [ÄKL05], which has many references.

### 4.3 Operational Amplifier Circuits

An operational amplifier (op amp) is a modern implementation of Black’s feedback amplifier. It is a universal component that is widely used for instrumentation, control and communication. It is also a key element in analog computing. Schematic diagrams of the operational amplifier are shown in Figure 4.7. The amplifier has one inverting input ( $v_-$ ), one noninverting input ( $v_+$ ) and one output ( $v_{\text{out}}$ ). There are also connections for the supply voltages,  $e_-$  and  $e_+$ , and a zero adjustment (offset null). A simple model is obtained by assuming that the input currents  $i_-$

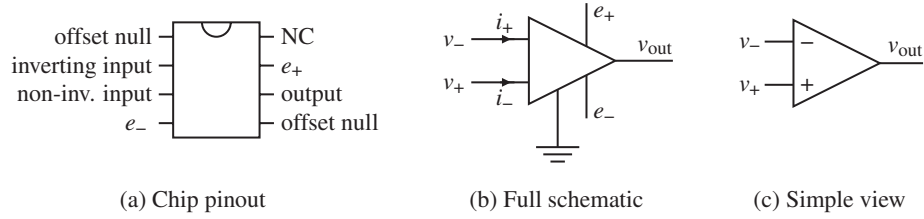

**Figure 4.7:** An operational amplifier and two schematic diagrams. (a) The amplifier pin connections on an integrated circuit chip. (b) A schematic with all connections. (c) Only the signal connections.

and  $i_+$  are zero and that the output is given by the static relation

$$v_{\text{out}} = \text{sat}_{(v_{\min}, v_{\max})}(k(v_+ - v_-)), \quad (4.8)$$

where  $\text{sat}$  denotes the saturation function

$$\text{sat}_{(a,b)}(x) = \begin{cases} a & \text{if } x < a \\ x & \text{if } a \leq x \leq b \\ b & \text{if } x > b. \end{cases} \quad (4.9)$$

We assume that the gain  $k$  is large, in the range of  $10^6$ – $10^8$ , and the voltages  $v_{\min}$  and  $v_{\max}$  satisfy

$$e_- \leq v_{\min} < v_{\max} \leq e_+$$

and hence are in the range of the supply voltages. More accurate models are obtained by replacing the saturation function with a smooth function as shown in Figure 4.8. For small input signals the amplifier characteristic (4.8) is linear:

$$v_{\text{out}} = k(v_+ - v_-) =: -kv. \quad (4.10)$$

Since the open loop gain  $k$  is very large, the range of input signals where the system is linear is very small.

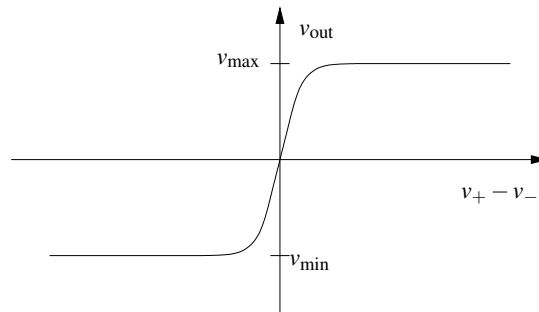

**Figure 4.8:** Input/output characteristics of an operational amplifier. The differential input is given by  $v_+ - v_-$ . The output voltage is a linear function of the input in a small range around 0, with saturation at  $v_{\min}$  and  $v_{\max}$ . In the linear regime the op amp has high gain.

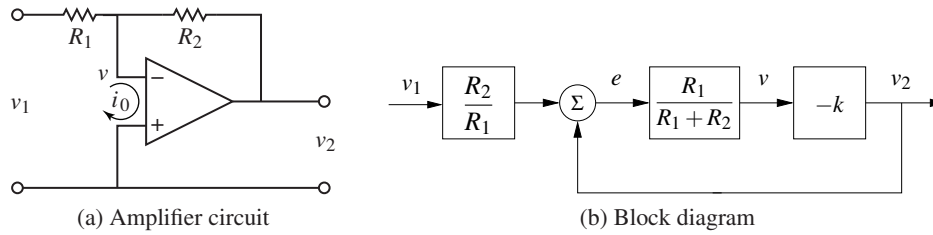

**Figure 4.9:** Stable amplifier using an op amp. The circuit (a) uses negative feedback around an operational amplifier and has a corresponding block diagram (b). The resistors  $R_1$  and  $R_2$  determine the gain of the amplifier.

A simple amplifier is obtained by arranging feedback around the basic operational amplifier as shown in Figure 4.9a. To model the feedback amplifier in the linear range, we assume that the current  $i_0 = i_- + i_+$  is zero and that the gain of the amplifier is so large that the voltage  $v = v_- - v_+$  is also zero. It follows from Ohm's law that the currents through resistors  $R_1$  and  $R_2$  are given by

$$\frac{v_1}{R_1} = -\frac{v_2}{R_2},$$

and hence the closed loop gain of the amplifier is

$$\frac{v_2}{v_1} = -k_{\text{cl}}, \quad \text{where} \quad k_{\text{cl}} = \frac{R_2}{R_1}. \quad (4.11)$$

A more accurate model is obtained by continuing to neglect the current  $i_0$  but assuming that the voltage  $v$  is small but not negligible. The current balance is then

$$\frac{v_1 - v}{R_1} = \frac{v - v_2}{R_2}. \quad (4.12)$$

Assuming that the amplifier operates in the linear range and using equation (4.10), the gain of the closed loop system becomes

$$k_{\text{cl}} = -\frac{v_2}{v_1} = \frac{R_2}{R_1} \frac{kR_1}{R_1 + R_2 + kR_1} \quad (4.13)$$

If the open loop gain  $k$  of the operational amplifier is large, the closed loop gain  $k_{\text{cl}}$  is the same as in the simple model given by equation (4.11). Notice that the closed loop gain depends only on the passive components and that variations in  $k$  have only a marginal effect on the closed loop gain. For example if  $k = 10^6$  and  $R_2/R_1 = 100$ , a variation of  $k$  by 100% gives only a variation of 0.01% in the closed loop gain. The drastic reduction in sensitivity is a nice illustration of how feedback can be used to make precise systems from uncertain components. In this particular case, feedback is used to trade high gain and low robustness for low gain and high robustness. Equation (4.13) was the formula that inspired Black when he invented the feedback amplifier [Bla34] (see the quote at the beginning of Chapter 13).

It is instructive to develop a block diagram for the feedback amplifier in Figure 4.9a. To do this we will represent the pure amplifier with input  $v$  and output  $v_2$

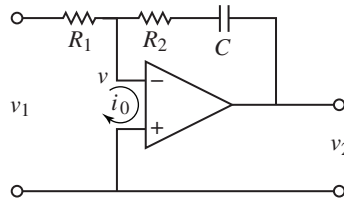

**Figure 4.10:** Circuit diagram of a PI controller obtained by feedback around an operational amplifier. The capacitor  $C$  is used to store charge and represents the integral of the input.

as one block. To complete the block diagram, we must describe how  $v$  depends on  $v_1$  and  $v_2$ . Solving equation (4.12) for  $v$  gives

$$v = \frac{R_2}{R_1 + R_2} v_1 + \frac{R_1}{R_1 + R_2} v_2 = \frac{R_1}{R_1 + R_2} \left( \frac{R_2}{R_1} v_1 + v_2 \right),$$

and we obtain the block diagram shown in Figure 4.9b. The diagram clearly shows that the system has feedback and that the gain from  $v_2$  to  $v$  is  $R_1/(R_1 + R_2)$ , which can also be read from the circuit diagram in Figure 4.9a. If the loop is stable and the gain of the amplifier is large, it follows that the error  $e$  is small, and we find that  $v_2 = -(R_2/R_1)v_1$ . Notice that the resistor  $R_1$  appears in two blocks in the block diagram. This situation is typical in electrical circuits, and it is one reason why block diagrams are not always well suited for some types of physical modeling.

The simple model of the amplifier given by equation (4.10) provides qualitative insight, but it neglects the fact that the amplifier is a dynamical system. A more realistic model is

$$\frac{dv_{\text{out}}}{dt} = -av_{\text{out}} - bv. \quad (4.14)$$

The parameter  $b$  that has dimensions of frequency and is called the *gain-bandwidth product* of the amplifier. Whether a more complicated model is used depends on the questions to be answered and the required size of the uncertainty lemon. The model (4.14) is still not valid for very high or very low frequencies since drift causes deviations at low frequencies and there are additional dynamics that appear at frequencies close to  $b$ . The model is also not valid for large signals—an upper limit is given by the voltage of the power supply, typically in the range of 5–10 V—neither is it valid for very low signals because of electrical noise. These effects can be added, if needed, but increase the complexity of the analysis.

The operational amplifier is very versatile, and many different systems can be built by combining it with resistors and capacitors. In fact, any linear system can be implemented by combining operational amplifiers with resistors and capacitors. Exercise 4.5 shows how a second-order oscillator is implemented, and Figure 4.10 shows the circuit diagram for an analog proportional-integral controller. To develop a simple model for the circuit we assume that the current  $i_0$  is zero and that the open loop gain  $k$  is so large that the input voltage  $v$  is negligible. The current  $i$  through the capacitor is  $i = Cdv_c/dt$ , where  $v_c$  is the voltage across the capacitor.



Since the same current goes through the resistor  $R_1$ , we get

$$i = \frac{v_1}{R_1} = C \frac{dv_c}{dt},$$

which implies that

$$v_c(t) = \frac{1}{C} \int i(t) dt = \frac{1}{R_1 C} \int_0^t v_1(\tau) d\tau.$$

The output voltage is thus given by

$$v_2(t) = -R_2 i - v_c = -\frac{R_2}{R_1} v_1(t) - \frac{1}{R_1 C} \int_0^t v_1(\tau) d\tau,$$

which is the input/output relation for a PI controller.

The development of operational amplifiers was pioneered by Philbrick [Lun05, Phi48], and their usage is described in many textbooks (e.g., [CD75]). Good information is also available from suppliers [Jun02, Man02].

## 4.4 Computing Systems and Networks

The application of feedback to computing systems follows the same principles as the control of physical systems, but the types of measurements and control inputs that can be used are somewhat different. Measurements (sensors) are typically related to resource utilization in the computing system or network and can include quantities such as the processor load, memory usage or network bandwidth. Control variables (actuators) typically involve setting limits on the resources available to a process. This might be done by controlling the amount of memory, disk space or time that a process can consume, turning on or off processing, delaying availability of a resource or rejecting incoming requests to a server process. Process modeling for networked computing systems is also challenging, and empirical models based on measurements are often used when a first-principles model is not available.

### Web Server Control

Web servers respond to requests from the Internet and provide information in the form of web pages. Modern web servers start multiple processes to respond to requests, with each process assigned to a single source until no further requests are received from that source for a predefined period of time. Processes that are idle become part of a pool that can be used to respond to new requests. To provide a fast response to web requests, it is important that the web server processes do not overload the server's computational capabilities or exhaust its memory. Since other processes may be running on the server, the amount of available processing power and memory is uncertain, and feedback can be used to provide good performance in the presence of this uncertainty.

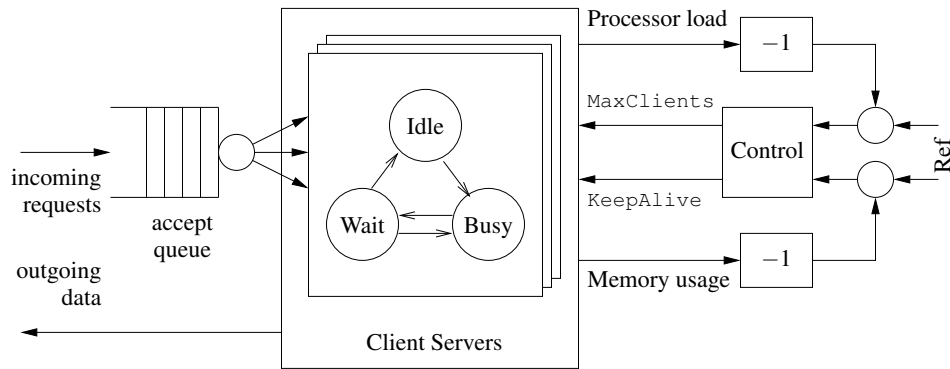

**Figure 4.11:** Feedback control of a web server. Connection requests arrive on an input queue, where they are sent to a server process. A finite state machine keeps track of the state of the individual server processes and responds to requests. A control algorithm can modify the server's operation by controlling parameters that affect its behavior, such as the maximum number of requests that can be serviced at a single time (`MaxClients`) or the amount of time that a connection can remain idle before it is dropped (`KeepAlive`).

Figure 4.11 illustrates the use of feedback to modulate the operation of an Apache web server. The web server operates by placing incoming connection requests on a queue and then starting a subprocess to handle requests for each accepted connection. This subprocess responds to requests from a given connection as they come in, alternating between a `Busy` state and a `Wait` state. (Keeping the subprocess active between requests is known as the *persistence* of the connection and provides a substantial reduction in latency to requests for multiple pieces of information from a single site.) If no requests are received for a sufficiently long period of time, controlled by the `KeepAlive` parameter, then the connection is dropped and the subprocess enters an `Idle` state, where it can be assigned another connection. A maximum of `MaxClients` simultaneous requests will be served, with the remainder remaining on the incoming request queue.

The parameters that control the server represent a trade-off between performance (how quickly requests receive a response) and resource usage (the amount of processing power and memory used by the server). Increasing the `MaxClients` parameter allows connection requests to be pulled off of the queue more quickly but increases the amount of processing power and memory usage that is required. Increasing the `KeepAlive` timeout means that individual connections can remain idle for a longer period of time, which decreases the processing load on the machine but increases the length of the queue (and hence the amount of time required for a user to initiate a connection). Successful operation of a busy server requires a proper choice of these parameters, often based on trial and error.

To model the dynamics of this system in more detail, we create a discrete-time model with states given by the average processor load  $x_{\text{cpu}}$  and the percentage memory usage  $x_{\text{mem}}$ . The inputs to the system are taken as the maximum number of clients  $u_{\text{mc}}$  and the keep-alive time  $u_{\text{ka}}$ . If we assume a linear model around the

equilibrium point, the dynamics can be written as

$$\begin{pmatrix} x_{\text{cpu}}[k+1] \\ x_{\text{mem}}[k+1] \end{pmatrix} = \begin{pmatrix} A_{11} & A_{12} \\ A_{21} & A_{22} \end{pmatrix} \begin{pmatrix} x_{\text{cpu}}[k] \\ x_{\text{mem}}[k] \end{pmatrix} + \begin{pmatrix} B_{11} & B_{12} \\ B_{21} & B_{22} \end{pmatrix} \begin{pmatrix} u_{\text{ka}}[k] \\ u_{\text{mc}}[k] \end{pmatrix}, \quad (4.15)$$

where the coefficients of the  $A$  and  $B$  matrices can be determined based on empirical measurements or detailed modeling of the web server's processing and memory usage. Using system identification, Diao et al. [DGH+02, HDPT04] identified the linearized dynamics as

$$A = \begin{pmatrix} 0.54 & -0.11 \\ -0.026 & 0.63 \end{pmatrix}, \quad B = \begin{pmatrix} -85 & 4.4 \\ -2.5 & 2.8 \end{pmatrix} \times 10^{-4},$$

where the system was linearized about the equilibrium point

$$x_{\text{cpu}} = 0.58, \quad u_{\text{ka}} = 11 \text{ s}, \quad x_{\text{mem}} = 0.55, \quad u_{\text{mc}} = 600.$$

This model shows the basic characteristics that were described above. Looking first at the  $B$  matrix, we see that increasing the `KeepAlive` timeout (first column of the  $B$  matrix) decreases both the processor usage and the memory usage since there is more persistence in connections and hence the server spends a longer time waiting for a connection to close rather than taking on a new active connection. The `MaxClients` connection increases both the processing and memory requirements. Note that the largest effect on the processor load is the `KeepAlive` timeout. The  $A$  matrix tells us how the processor and memory usage evolve in a region of the state space near the equilibrium point. The diagonal terms describe how the individual resources return to equilibrium after a transient increase or decrease. The off-diagonal terms show that there is coupling between the two resources, so that a change in one could cause a later change in the other.

Although this model is very simple, we will see in later examples that it can be used to modify the parameters controlling the server in real time and provide robustness with respect to uncertainties in the load on the machine. Similar types of mechanisms have been used for other types of servers. It is important to remember the assumptions on the model and their role in determining when the model is valid. In particular, since we have chosen to use average quantities over a given sample time, the model will not provide an accurate representation for high-frequency phenomena.

### Congestion Control

The Internet was created to obtain a large, highly decentralized, efficient and expandable communication system. The system consists of a large number of interconnected gateways. A message is split into several packets which are transmitted over different paths in the network, and the packages are rejoined to recover the message at the receiver. An acknowledgment (“ack”) message is sent back to the sender when a packet is received. The operation of the system is governed by a simple but powerful decentralized control structure that has evolved over time.

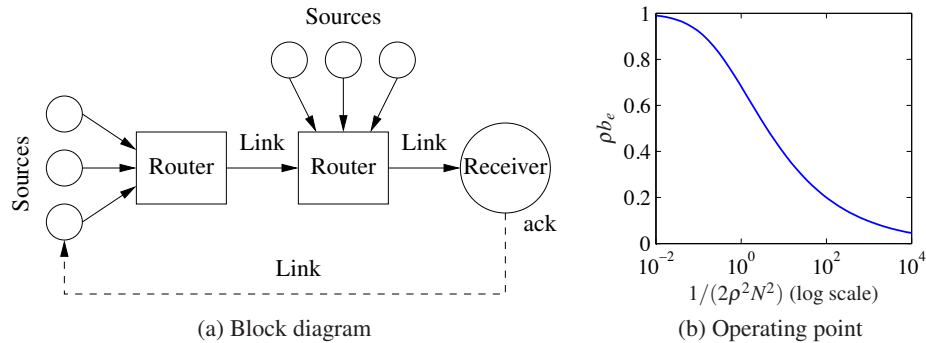

**Figure 4.12:** Internet congestion control. (a) Source computers send information to routers, which forward the information to other routers that eventually connect to the receiving computer. When a packet is received, an acknowledgment packet is sent back through the routers (not shown). The routers buffer information received from the sources and send the data across the outgoing link. (b) The equilibrium buffer size  $b_e$  for a set of  $N$  identical computers sending packets through a single router with drop probability  $\rho$ .

The system has two control mechanisms called *protocols*: the Transmission Control Protocol (TCP) for end-to-end network communication and the Internet Protocol (IP) for routing packets and for host-to-gateway or gateway-to-gateway communication. The current protocols evolved after some spectacular congestion collapses occurred in the mid 1980s, when throughput unexpectedly could drop by a factor of 1000 [Jac95]. The control mechanism in TCP is based on conserving the number of packets in the loop from the sender to the receiver and back to the sender. The sending rate is increased exponentially when there is no congestion, and it is dropped to a low level when there is congestion.

To derive an overall model for congestion control, we model three separate elements of the system: the rate at which packets are sent by individual sources (computers), the dynamics of the queues in the links (routers) and the admission control mechanism for the queues. Figure 4.12a is a block diagram of the system.

The current source control mechanism on the Internet is a protocol known as TCP/Reno [LPD02]. This protocol operates by sending packets to a receiver and waiting to receive an acknowledgment from the receiver that the packet has arrived. If no acknowledgment is sent within a certain timeout period, the packet is retransmitted. To avoid waiting for the acknowledgment before sending the next packet, Reno transmits multiple packets up to a fixed *window* around the latest packet that has been acknowledged. If the window length is chosen properly, packets at the beginning of the window will be acknowledged before the source transmits packets at the end of the window, allowing the computer to continuously stream packets at a high rate.

To determine the size of the window to use, TCP/Reno uses a feedback mechanism in which (roughly speaking) the window size is increased by 1 every time a packet is acknowledged and the window size is cut in half when packets are lost. This mechanism allows a dynamic adjustment of the window size in which each

computer acts in a greedy fashion as long as packets are being delivered but backs off quickly when congestion occurs.

A model for the behavior of the source can be developed by describing the dynamics of the window size. Suppose we have  $N$  computers and let  $w_i$  be the current window size (measured in number of packets) for the  $i$ th computer. Let  $q_i$  represent the end-to-end probability that a packet will be dropped someplace between the source and the receiver. We can model the dynamics of the window size by the differential equation

$$\frac{dw_i}{dt} = (1 - q_i) \frac{r_i(t - \tau_i)}{w_i} + q_i \left(-\frac{w_i}{2} r_i(t - \tau_i)\right), \quad r_i = \frac{w_i}{\tau_i}, \quad (4.16)$$

where  $\tau_i$  is the end-to-end transmission time for a packet to reach its destination and the acknowledgment to be sent back and  $r_i$  is the resulting rate at which packets are cleared from the list of packets that have been received. The first term in the dynamics represents the increase in window size when a packet is received, and the second term represents the decrease in window size when a packet is lost. Notice that  $r_i$  is evaluated at time  $t - \tau_i$ , representing the time required to receive additional acknowledgments.

The link dynamics are controlled by the dynamics of the router queue and the admission control mechanism for the queue. Assume that we have  $L$  links in the network and use  $l$  to index the individual links. We model the queue in terms of the current number of packets in the router's buffer  $b_l$  and assume that the router can contain a maximum of  $b_{l,\max}$  packets and transmits packets at a rate  $c_l$ , equal to the capacity of the link. The buffer dynamics can then be written as

$$\frac{db_l}{dt} = s_l - c_l, \quad s_l = \sum_{\{i: l \in L_i\}} r_i(t - \tau_{li}^f), \quad (4.17)$$

where  $L_i$  is the set of links that are being used by source  $i$ ,  $\tau_{li}^f$  is the time it takes a packet from source  $i$  to reach link  $l$  and  $s_l$  is the total rate at which packets arrive at link  $l$ .

The admission control mechanism determines whether a given packet is accepted by a router. Since our model is based on the average quantities in the network and not the individual packets, one simple model is to assume that the probability that a packet is dropped depends on how full the buffer is:  $p_l = m_l(b_l, b_{\max})$ . For simplicity, we will assume for now that  $p_l = \rho_l b_l$  (see Exercise 4.6 for a more detailed model). The probability that a packet is dropped at a given link can be used to determine the end-to-end probability that a packet is lost in transmission:

$$q_i = 1 - \prod_{l \in L_i} (1 - p_l) \approx \sum_{l \in L_i} p_l(t - \tau_{li}^b), \quad (4.18)$$

where  $\tau_{li}^b$  is the backward delay from link  $l$  to source  $i$  and the approximation is valid as long as the individual drop probabilities are small. We use the backward delay since this represents the time required for the acknowledgment packet to be received by the source.

Together, equations (4.16), (4.17) and (4.18) represent a model of congestion control dynamics. We can obtain substantial insight by considering a special case in which we have  $N$  identical sources and 1 link. In addition, we assume for the moment that the forward and backward time delays can be ignored, in which case the dynamics can be reduced to the form

$$\frac{dw_i}{dt} = \frac{1}{\tau} - \frac{\rho c(2 + w_i^2)}{2}, \quad \frac{db}{dt} = \sum_{i=1}^N \frac{w_i}{\tau} - c, \quad \tau = \frac{b}{c}, \quad (4.19)$$

where  $w_i \in \mathbb{R}$ ,  $i = 1, \dots, N$ , are the window sizes for the sources of data,  $b \in \mathbb{R}$  is the current buffer size of the router,  $\rho$  controls the rate at which packets are dropped and  $c$  is the capacity of the link connecting the router to the computers. The variable  $\tau$  represents the amount of time required for a packet to be processed by a router, based on the size of the buffer and the capacity of the link. Substituting  $\tau$  into the equations, we write the state space dynamics as

$$\frac{dw_i}{dt} = \frac{c}{b} - \rho c \left( 1 + \frac{w_i^2}{2} \right), \quad \frac{db}{dt} = \sum_{i=1}^N \frac{cw_i}{b} - c. \quad (4.20)$$

More sophisticated models can be found in [HMTG00, LPD02].

The nominal operating point for the system can be found by setting  $\dot{w}_i = \dot{b} = 0$ :

$$0 = \frac{c}{b} - \rho c \left( 1 + \frac{w_i^2}{2} \right), \quad 0 = \sum_{i=1}^N \frac{cw_i}{b} - c.$$

Exploiting the fact that all of the source dynamics are identical, it follows that all of the  $w_i$  should be the same, and it can be shown that there is a unique equilibrium satisfying the equations

$$w_{i,e} = \frac{b_e}{N} = \frac{c\tau_e}{N}, \quad \frac{1}{2\rho^2 N^2} (\rho b_e)^3 + (\rho b_e) - 1 = 0. \quad (4.21)$$

The solution for the second equation is a bit messy but can easily be determined numerically. A plot of its solution as a function of  $1/(2\rho^2 N^2)$  is shown in Figure 4.12b. We also note that at equilibrium we have the following additional equalities:

$$\tau_e = \frac{b_e}{c} = \frac{Nw_e}{c}, \quad q_e = Np_e = N\rho b_e, \quad r_e = \frac{w_e}{\tau_e}. \quad (4.22)$$

Figure 4.13 shows a simulation of 60 sources communicating across a single link, with 20 sources dropping out at  $t = 500$  ms and the remaining sources increasing their rates (window sizes) to compensate. Note that the buffer size and window sizes automatically adjust to match the capacity of the link.

A comprehensive treatment of computer networks is given in the textbook by Tannenbaum [Tan96]. A good presentation of the ideas behind the control principles for the Internet is given by one of its designers, Van Jacobson, in [Jac95]. F. Kelly [Kel85] presents an early effort on the analysis of the system. The books by

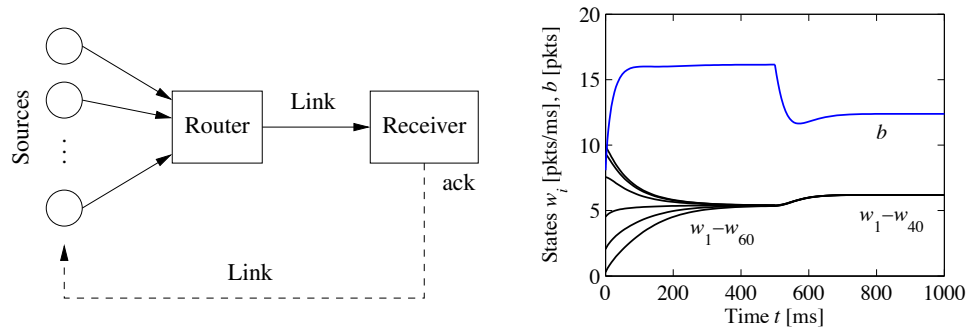

**Figure 4.13:** Internet congestion control for  $N$  identical sources across a single link. As shown on the left, multiple sources attempt to communicate through a router across a single link. An “ack” packet sent by the receiver acknowledges that the message was received; otherwise the message packet is resent and the sending rate is slowed down at the source. The simulation on the right is for 60 sources starting random rates, with 20 sources dropping out at  $t = 500$  ms. The buffer size is shown at the top, and the individual source rates for 6 of the sources are shown at the bottom.

Hellerstein et al. [HDPT04] and Janert [Jan14] give many examples of the use of feedback in computer systems.

## 4.5 Atomic Force Microscopy

The 1986 Nobel Prize in Physics was shared by Gerd Binnig and Heinrich Rohrer for their design of the *scanning tunneling microscope*. The idea of the instrument is to bring an atomically sharp tip so close to a conducting surface that tunneling occurs. An image is obtained by traversing the tip across the sample and measuring the tunneling current as a function of tip position. This invention has stimulated the development of a family of instruments that permit visualization of surface structure at the nanometer scale, including the *atomic force microscope* (AFM), where a sample is probed by a tip on a cantilever. An AFM can operate in two modes. In *tapping mode* the cantilever is vibrated, and the amplitude of vibration is controlled by feedback. In *contact mode* the cantilever is in contact with the sample, and its bending is controlled by feedback. In both cases control is actuated by a piezo element that controls the vertical position of the cantilever base (or the sample). The control system has a direct influence on picture quality and scanning rate.

A schematic picture of an atomic force microscope is shown in Figure 4.14a. A microcantilever with a tip having a radius of the order of 10 nm is placed close to the sample. The tip can be moved vertically and horizontally using a piezoelectric scanner. It is clamped to the sample surface by attractive van der Waals forces and repulsive Pauli forces. The cantilever tilt depends on the topography of the surface and the position of the cantilever base, which is controlled by the piezo element.

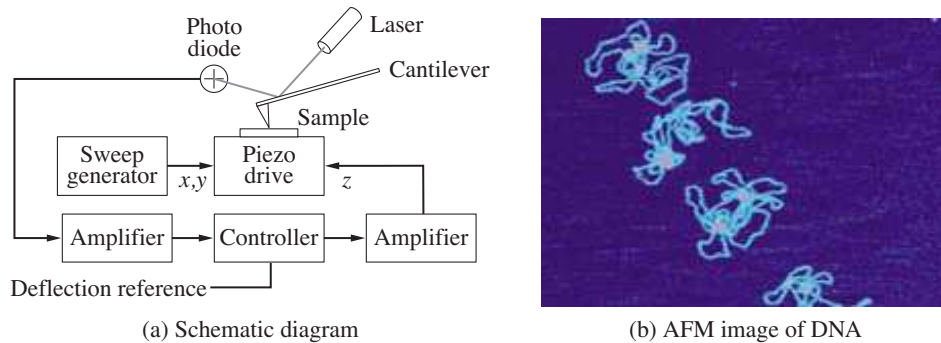

**Figure 4.14:** Atomic force microscope. (a) A schematic diagram of an atomic force microscope, consisting of a piezo drive that scans the sample under the AFM tip. A laser reflects off of the cantilever and is used to measure the deflection of the tip through a feedback controller. (b) An AFM image of strands of DNA. (Image courtesy Veeco Instruments.)

The tilt is measured by sensing the deflection of the laser beam using a photodiode. The signal from the photodiode is amplified and sent to a controller that drives the amplifier for the vertical position of the cantilever. By controlling the piezo element so that the deflection of the cantilever is constant, the signal driving the vertical deflection of the piezo element is a measure of the atomic forces between the cantilever tip and the atoms of the sample. An image of the surface is obtained by scanning the cantilever along the sample. The resolution makes it possible to see the structure of the sample on the atomic scale, as illustrated in Figure 4.14b, which shows an AFM image of DNA.

The horizontal motion of an AFM is typically modeled as a spring–mass system with low damping. The vertical motion is more complicated. To model the system, we start with the block diagram shown in Figure 4.15. Signals that are easily accessible are the input voltage  $u$  to the power amplifier that drives the piezo element, the voltage  $v$  applied to the piezo element and the output voltage  $y$  of the signal amplifier for the photodiode. The controller is a PI controller implemented by a computer, which is connected to the system by analog-to-digital (A/D) and digital-to-analog (D/A) converters. The deflection of the cantilever  $\phi$  is also shown in the figure. The desired reference value for the deflection is an input to the computer.

There are several different configurations that have different dynamics. Here we will discuss a high-performance system from [SÅD+07] where the cantilever base is positioned vertically using a piezo stack. We begin the modeling with a simple experiment on the system. Figure 4.16a shows a step response of a scanner from the input voltage  $u$  to the power amplifier to the output voltage  $y$  of the signal amplifier for the photodiode. This experiment captures the dynamics of the chain of blocks from  $u$  to  $y$  in the block diagram in Figure 4.15. Figure 4.16a shows that the system responds quickly but that there is a poorly damped oscillatory mode with a period of about  $35 \mu\text{s}$ . A primary task of the modeling is to understand the origin of the oscillatory behavior. To do so we will explore the system in more



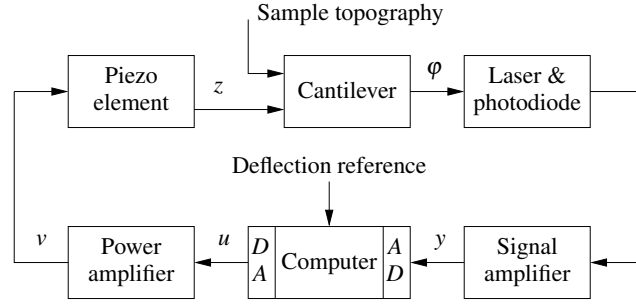

**Figure 4.15:** Block diagram of the system for vertical positioning of the cantilever for an atomic force microscope in contact mode. The control system attempts to keep the cantilever deflection equal to its reference value. Cantilever deflection is measured, amplified and converted to a digital signal, then compared with its reference value. A correcting signal is generated by the computer, converted to analog form, amplified and sent to the piezo element.

detail.

The natural frequency of the clamped cantilever is typically several hundred kilohertz, which is much higher than the observed oscillation of about 30 kHz. As a first approximation we will model it as a static system. Since the deflections are small, we can assume that the bending  $\phi$  of the cantilever is proportional to the difference in height between the cantilever tip at the probe and the piezo scanner. A more accurate model can be obtained by modeling the cantilever as a spring-mass system of the type discussed in Chapter 3.

Figure 4.16a also shows that the response of the power amplifier is fast. The photodiode and the signal amplifier also have fast responses and can thus be modeled as static systems. The remaining block is a piezo system with suspension. A schematic mechanical representation of the vertical motion of the scanner is shown in Figure 4.16b. We will model the system as two masses separated by an ideal piezo element. The mass  $m_1$  is half of the piezo system, and the mass  $m_2$  is the other half of the piezo system plus the mass of the support.

A simple model is obtained by assuming that the piezo crystal generates a force  $F$  between the masses and that there is a damping  $c$  in the spring. Let the positions of the center of the masses be  $z_1$  and  $z_2$ . A momentum balance gives the following model for the system:

$$m_1 \frac{d^2 z_1}{dt^2} = F, \quad m_2 \frac{d^2 z_2}{dt^2} = -c_2 \frac{dz_2}{dt} - k_2 z_2 - F.$$

Let the elongation of the piezo element  $l = z_1 - z_2$  be the control variable and the height  $z_1$  of the cantilever base be the output. Eliminating the variable  $F$  in the equations above and substituting  $z_1 - l$  for  $z_2$  gives the model

$$(m_1 + m_2) \frac{d^2 z_1}{dt^2} + c_2 \frac{dz_1}{dt} + k_2 z_1 = m_2 \frac{d^2 l}{dt^2} + c_2 \frac{dl}{dt} + k_2 l. \quad (4.23)$$

Summarizing, we find that a simple model of the system is obtained by mod-

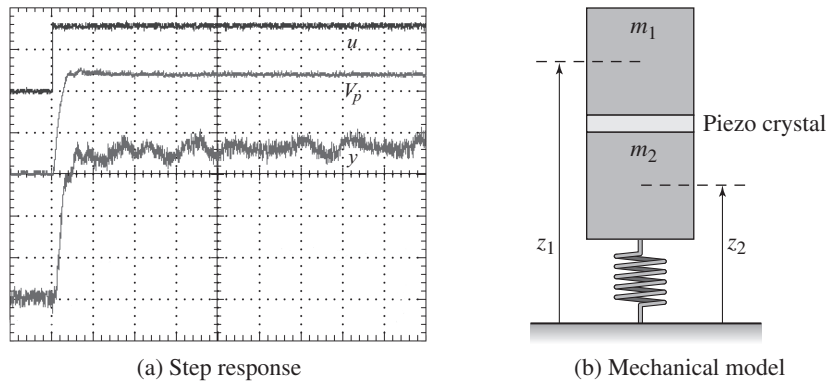

**Figure 4.16:** Modeling of an atomic force microscope. (a) A measured step response. The top curve shows the voltage  $u$  applied to the drive amplifier (50 mV/div), the middle curve is the output  $V_p$  of the power amplifier (500 mV/div) and the bottom curve is the output  $y$  of the signal amplifier (500 mV/div). The time scale is 25  $\mu$ s/div. Data have been supplied by Georg Schitter. (b) A simple mechanical model for the vertical positioner and the piezo crystal.

eling the piezo by (4.23) and all the other blocks by static models. Introducing the linear equations  $l = k_3 u$  and  $y = k_4 z_1$ , we now have a complete model relating the output  $y$  to the control signal  $u$ . A more accurate model can be obtained by introducing the dynamics of the cantilever and the power amplifier. As in the previous examples, the concept of the uncertainty lemon in Figure 3.5b provides a framework for describing the uncertainty: the model will be accurate up to the frequencies of the fastest modeled modes and over a range of motion in which linearized stiffness models can be used.

The experimental results in Figure 4.16a can be explained qualitatively as follows. When a voltage is applied to the piezo, it expands by  $l_0$ , the mass  $m_1$  moves up and the mass  $m_2$  moves down instantaneously. The system settles after a poorly damped oscillation.

It is highly desirable to design a control system for the vertical motion so that it responds quickly with little oscillation. The instrument designer has several choices: to accept the oscillation and have a slow response time, to design a control system that can damp the oscillations or to redesign the mechanics to give resonances of higher frequency. The last two alternatives give a faster response and faster imaging.

Since the dynamic behavior of the system changes with the properties of the sample, it is necessary to tune the feedback loop. In simple systems this is currently done manually by adjusting parameters of a PI controller. There are interesting possibilities for making AFM systems easier to use by introducing automatic tuning and adaptation.

The book by Sarid [Sar91] gives a broad coverage of atomic force microscopes. The interaction of atoms close to surfaces is fundamental to solid state physics, see Kittel [Kit95]. The model discussed in this section is based on Schitter [Sch01].

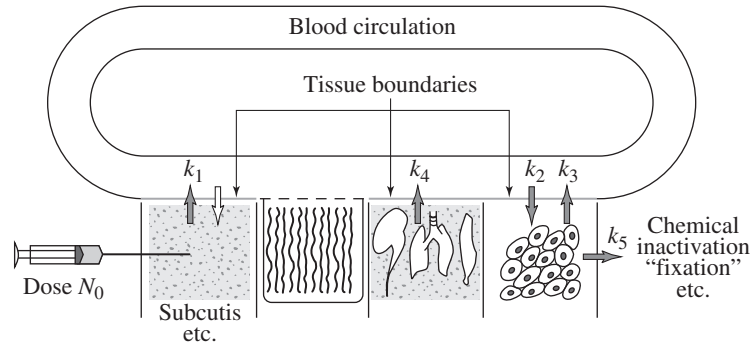

**Figure 4.17:** Abstraction used to compartmentalize the body for the purpose of describing drug distribution (based on Teorell [Teo37]). The body is abstracted by a number of compartments with perfect mixing, and the complex transport processes are approximated by assuming that the flow is proportional to the concentration differences in the compartments. The constants  $k_i$  parameterize the rates of flow between different compartments.

## 4.6 Drug Administration

The phrase “Take two pills three times a day” is a recommendation with which we are all familiar. Behind this recommendation is a solution of an open loop control problem. The key issue is to make sure that the concentration of a medicine in a part of the body is sufficiently high to be effective but not so high that it will cause undesirable side effects. The control action is quantized, *take two pills*, and sampled, *every 8 hours*. The prescriptions are based on simple models captured in empirical tables, and the dose is based on the age and weight of the patient.

Drug administration is a control problem. To solve it we must understand how a drug spreads in the body after it is administered. This topic, called *pharmacokinetics*, is now a discipline of its own, and the models used are called *compartment models*. They go back to the 1920s when Widmark modeled the propagation of alcohol in the body [WT24]. Compartment models are now important for the screening of all drugs used by humans. The schematic diagram in Figure 4.17 illustrates the idea of a compartment model. The body is viewed as a number of compartments like blood plasma, kidney, liver and tissues that are separated by membranes. It is assumed that there is perfect mixing so that the drug concentration is constant in each compartment. The complex transport processes are approximated by assuming that the flow rates between the compartments are proportional to the concentration differences in the compartments.

To describe the effect of a drug it is necessary to know both its concentration and how it influences the body. The relation between concentration  $c$  and its effect  $e$  is typically nonlinear. A simple model is

$$e = \frac{c}{c_0 + c} e_{\max}. \quad (4.24)$$

The effect is linear for low concentrations, and it saturates at high concentrations. The relation can also be dynamic, and it is then called *pharmacodynamics*.

### Compartment Models

The simplest dynamic model for drug administration is obtained by assuming that the drug is evenly distributed in a single compartment after it has been administered and that the drug is removed at a rate proportional to the concentration. The compartments behave like stirred tanks with perfect mixing. Let  $c$  be the concentration,  $V$  the volume and  $q$  the outflow rate. Converting the description of the system into differential equations gives the model

$$V \frac{dc}{dt} = -qc, \quad c \geq 0. \quad (4.25)$$

This equation has the solution  $c(t) = c_0 e^{-qt/V} = c_0 e^{-kt}$ , which shows that the concentration decays exponentially with the time constant  $T = V/q$  after an injection. The input is introduced implicitly as an initial condition in the model (4.25). More generally, the way the input enters the model depends on how the drug is administered. For example, the input can be represented as a mass flow into the compartment where the drug is injected. A pill that is dissolved can also be interpreted as an input in terms of a mass flow rate.

The model (4.25) is called a *one-compartment model* or a *single-pool model*. The parameter  $q/V$  is called the elimination rate constant. This simple model is often used to model the concentration in the blood plasma. By measuring the concentration at a few times, the initial concentration can be obtained by extrapolation. If the total amount of injected substance is known, the volume  $V$  can then be determined as  $V = m/c_0$ ; this volume is called the *apparent volume of distribution*. This volume is larger than the real volume if the concentration in the plasma is lower than in other parts of the body. The model (4.25) is very simple, and there are large individual variations in the parameters. The parameters  $V$  and  $q$  are often normalized by dividing by the weight of the person. Typical parameters for aspirin are  $V = 0.2$  L/kg and  $q = 0.01$  (L/h)/kg. These numbers can be compared with a blood volume of 0.07 L/kg, a plasma volume of 0.05 L/kg, an intracellular fluid volume of 0.4 L/kg and an outflow of 0.0015 L/min/kg.

The simple one-compartment model captures the gross behavior of drug distribution, but it is based on many simplifications. Improved models can be obtained by considering the body as composed of several compartments. Examples of such systems are shown in Figure 4.18, where the compartments are represented as circles and the flows by arrows.

Modeling will be illustrated using the two-compartment model in Figure 4.18a. We assume that there is perfect mixing in each compartment and that the transport between the compartments is driven by concentration differences. We further assume that a drug with concentration  $c_0$  is injected in compartment 1 at a volume flow rate of  $u$  and that the concentration in compartment 2 is the output. Let  $c_1$  and  $c_2$  be the concentrations of the drug in the compartments, and let  $V_1$  and  $V_2$  be the

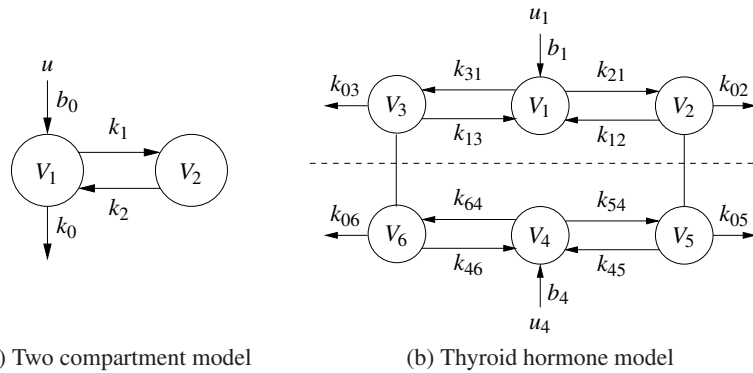

**Figure 4.18:** Schematic diagrams of compartment models. (a) A simple two-compartment model. Each compartment is labeled by its volume, and arrows indicate the flow of chemical into, out of and between compartments. (b) A system with six compartments used to study the metabolism of thyroid hormone [God83]. The notation  $k_{ij}$  denotes the transport from compartment  $j$  to compartment  $i$ .

volumes of the compartments. The mass balances for the compartments are

$$\begin{aligned} V_1 \frac{dc_1}{dt} &= q(c_2 - c_1) - q_0 c_1 + c_0 u, & c_1 &\geq 0, \\ V_2 \frac{dc_2}{dt} &= q(c_1 - c_2), & c_2 &\geq 0, \\ y &= c_2, \end{aligned} \quad (4.26)$$

where  $q$  represents flow rate between the compartments and  $q_0$  represents the flow rate out of compartment 1 that is not going to compartment 2. Introducing the variables  $k_0 = q_0/V_1$ ,  $k_1 = q/V_1$ ,  $k_2 = q/V_2$  and  $b_0 = c_0/V_1$  and using matrix notation, the model can be written as

$$\frac{dc}{dt} = \begin{pmatrix} -k_0 - k_1 & k_1 \\ k_2 & -k_2 \end{pmatrix} c + \begin{pmatrix} b_0 \\ 0 \end{pmatrix} u, \quad y = \begin{pmatrix} 0 & 1 \end{pmatrix} c. \quad (4.27)$$

Comparing this model with its graphical representation in Figure 4.18a, we find that the mathematical representation (4.27) can be written by inspection.

It should also be emphasized that simple compartment models such as the one in equation (4.27) have a limited range of validity. Low-frequency limits exist because the human body changes with time, and since the compartment model uses average concentrations, they will not accurately represent rapid changes. There are also nonlinear effects that influence transportation between the compartments.

Compartment models are widely used in medicine, engineering and environmental science. An interesting property of these systems is that variables like concentration and mass are always positive. An essential difficulty in compartment modeling is deciding how to divide a complex system into compartments. Compartment models can also be nonlinear, as illustrated in the next section.

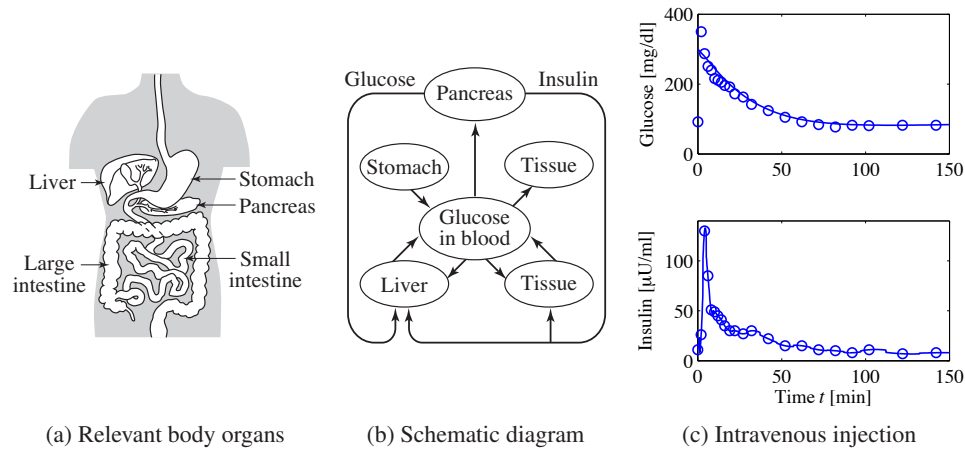

**Figure 4.19:** Insulin–glucose dynamics. (a) Sketch of body parts involved in the control of glucose. (b) Schematic diagram of the system. (c) Responses of insulin and glucose when glucose is injected intravenously. From [PB86].

### Insulin–glucose Dynamics

It is essential that the blood glucose concentration in the body is kept within a narrow range (0.7–1.1 g/L). Glucose concentration is influenced by many factors like food intake, digestion and exercise. A schematic picture of the relevant parts of the body is shown in Figures 4.19a and b.

There is a sophisticated mechanism that regulates glucose concentration. Glucose concentration is maintained by the pancreas, which secretes the hormones insulin and glucagon. Glucagon is released into the bloodstream when the glucose level is low. It acts on cells in the liver that release glucose. Insulin is secreted when the glucose level is high, and the glucose level is lowered by causing the liver and other cells to take up more glucose. In diseases like juvenile diabetes the pancreas is unable to produce insulin and the patient must inject insulin into the body to maintain a proper glucose level.

The mechanisms that regulate glucose and insulin are complicated; dynamics with time scales that range from seconds to hours have been observed. Models of different complexity have been developed. The models are typically tested with data from experiments where glucose is injected intravenously and insulin and glucose concentrations are measured at regular time intervals.

A relatively simple model called the *minimal model* was developed by Bergman and coworkers [Ber89]. This model uses two compartments, one representing the concentration of glucose in the bloodstream and the other representing the concentration of insulin in the interstitial fluid. Insulin in the bloodstream is considered an input. The reaction of glucose to insulin can be modeled by the equations

$$\frac{dx_1}{dt} = -(p_1 + x_2)x_1 + p_1 g_e, \quad \frac{dx_2}{dt} = -p_2 x_2 + p_3(u - i_e), \quad (4.28)$$

where  $g_e$  and  $i_e$  represent the equilibrium values of glucose and insulin,  $x_1$  is the concentration of glucose and  $x_2$  is proportional to the concentration of interstitial insulin. Notice the presence of the term  $x_2x_1$  in the first equation. Also notice that the model does not capture the complete feedback loop because it does not describe how the pancreas reacts to the glucose. Figure 4.19c shows a fit of the model to a test on a normal person where glucose was injected intravenously at time  $t = 0$ . The glucose concentration rises rapidly, and the pancreas responds with a rapid spikelike injection of insulin. The glucose and insulin levels then gradually approach the equilibrium values.

Models of the type in equation (4.28) and more complicated models having many compartments have been developed and fitted to experimental data. A difficulty in modeling is that there are significant variations in model parameters over time and for different patients. For example, the parameter  $p_1$  in equation (4.28) has been reported to vary with an order of magnitude for healthy individuals. The models have been used for diagnosis and to develop schemes for the treatment of persons with diseases. Attempts to develop a fully automatic artificial pancreas have been hampered by the lack of reliable sensors.

The papers by Widmark and Tandberg [WT24] and Teorell [Teo37] are classics in pharmacokinetics, which is now an established discipline with many textbooks [Dos68, Jac72, GP82]. Because of its medical importance, pharmacokinetics is now an essential component of drug development. The book by Riggs [Rig63] is a good source for the modeling of physiological systems, and a more mathematical treatment is given in [KS01]. Compartment models are discussed in [God83]. The problem of determining rate coefficients from experimental data is discussed in [BÅ70] and [God83]. There are many publications on the insulin–glucose model. The minimal model is discussed in [CT84, Ber89] and more recent references are [MLK06, FCF+06].

## 4.7 Population Dynamics

Population growth is a complex dynamic process that involves the interaction of one or more species with their environment and the larger ecosystem. The dynamics of population groups are interesting and important in many different areas of social and environmental policy. There are examples where new species have been introduced into new habitats, sometimes with disastrous results. There have also been attempts to control population growth both through incentives and through legislation. In this section we describe some of the models that can be used to understand how populations evolve with time and as a function of their environments.

### Logistic Growth Model

Let  $x$  be the population of a species at time  $t$ . A simple model is to assume that the birth rates and mortality rates are proportional to the total population. This gives

the linear model

$$\frac{dx}{dt} = bx - dx = (b - d)x = rx, \quad x \geq 0, \quad (4.29)$$

where birth rate  $b$  and mortality rate  $d$  are parameters. The model gives an exponential increase if  $b > d$  or an exponential decrease if  $b < d$ . A more realistic model is to assume that the birth rate decreases when the population is large. The following modification of the model (4.29) has this property:

$$\frac{dx}{dt} = rx\left(1 - \frac{x}{k}\right), \quad x \geq 0, \quad (4.30)$$

where  $k$  is the *carrying capacity* of the environment. The model (4.30) is called the *logistic growth model*.

### Predator–Prey Models

A more sophisticated model of population dynamics includes the effects of competing populations, where one species may feed on another. This situation, referred to as the *predator–prey problem*, was introduced in Example 3.3, where we developed a discrete-time model that captured some of the features of historical records of lynx and hare populations.

In this section, we replace the difference equation model used there with a more sophisticated differential equation model. Let  $H(t)$  represent the number of hares (prey) and let  $L(t)$  represent the number of lynxes (predator). The dynamics of the system are modeled as

$$\begin{aligned} \frac{dH}{dt} &= rH \left(1 - \frac{H}{k}\right) - \frac{aHL}{c + H}, & H &\geq 0, \\ \frac{dL}{dt} &= b \frac{aHL}{c + H} - dL, & L &\geq 0. \end{aligned} \quad (4.31)$$

In the first equation,  $r$  represents the growth rate of the hares,  $k$  represents the maximum population of the hares (in the absence of lynxes),  $a$  represents the interaction term that describes how the hares are diminished as a function of the lynx population and  $c$  controls the prey consumption rate for low hare population. In the second equation,  $b$  represents the growth coefficient of the lynxes and  $d$  represents the mortality rate of the lynxes. Note that the hare dynamics include a term that resembles the logistic growth model (4.30).

Of particular interest are the values at which the population values remain constant, called *equilibrium points*. The equilibrium points for this system can be determined by setting the right-hand side of the above equations to zero. Letting  $H_e$  and  $L_e$  represent the equilibrium state, from the second equation we have

$$L_e = 0 \quad \text{or} \quad H_e^* = \frac{cd}{ab - d}. \quad (4.32)$$

Substituting this into the first equation, we have that for  $L_e = 0$  either  $H_e = 0$  or



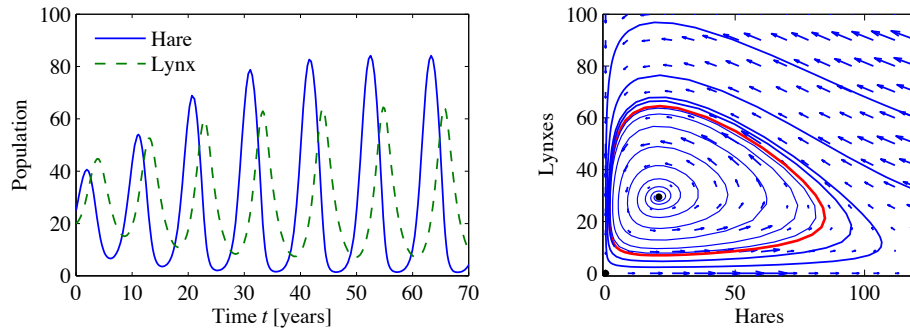

**Figure 4.20:** Simulation of the predator–prey system. The figure on the left shows a simulation of the two populations as a function of time. The figure on the right shows the populations plotted against each other, starting from different values of the population. The oscillation seen in both figures is an example of a *limit cycle*. The parameter values used for the simulations are  $a = 3.2$ ,  $b = 0.6$ ,  $c = 50$ ,  $d = 0.56$ ,  $k = 125$  and  $r = 1.6$ .

$H_e = k$ . For  $L_e \neq 0$ , we obtain

$$L_e^* = \frac{rH_e(c + H_e)}{aH_e} \left(1 - \frac{H_e}{k}\right) = \frac{bcr(abk - cd - dk)}{(ab - d)^2k}. \quad (4.33)$$

Thus, we have three possible equilibrium points  $x_e = (L_e, H_e)$ :

$$x_e = \begin{pmatrix} 0 \\ 0 \end{pmatrix}, \quad x_e = \begin{pmatrix} k \\ 0 \end{pmatrix}, \quad x_e = \begin{pmatrix} H_e^* \\ L_e^* \end{pmatrix},$$

where  $H_e^*$  and  $L_e^*$  are given in equations (4.32) and (4.33). Note that the equilibrium populations may be negative for some parameter values, corresponding to a nonachievable equilibrium point.

Figure 4.20 shows a simulation of the dynamics starting from a set of population values near the nonzero equilibrium values. We see that for this choice of parameters, the simulation predicts an oscillatory population count for each species, reminiscent of the data shown in Figure 3.7.

Volume I of the two-volume set by J. D. Murray [Mur04] give a broad coverage of population dynamics.

## Exercises

**4.1** (Cruise control) Consider the cruise control example described in Section 4.1. Build a simulation that re-creates the response to a hill shown in Figure 4.3b and show the effects of increasing and decreasing the mass of the car by 25%. Redesign the controller (using trial and error is fine) so that it returns to within 1% of the desired speed within 3 s of encountering the beginning of the hill.

**4.2 (Bicycle dynamics)** Show that the dynamics of a bicycle frame given by equation (4.5) can be approximated in state space form as

$$\frac{d}{dt} \begin{pmatrix} x_1 \\ x_2 \end{pmatrix} = \begin{pmatrix} 0 & 1 \\ mgh/J & 0 \end{pmatrix} \begin{pmatrix} x_1 \\ x_2 \end{pmatrix} + \begin{pmatrix} Dv_0/(bJ) \\ mv_0^2h/(bJ) \end{pmatrix} u,$$

$$y = \begin{pmatrix} 1 & 0 \end{pmatrix} x,$$

where the input  $u$  is the steering angle  $\delta$  and the output  $y$  is the tilt angle  $\varphi$ . What do the states  $x_1$  and  $x_2$  represent?

**4.3 (Bicycle steering)** Combine the bicycle model given by equation (4.5) and the model for steering kinematics in Example 3.10 to obtain a model that describes the path of the center of mass of the bicycle.

**4.4 (Operational amplifier circuit)** Consider the op amp circuit shown below.

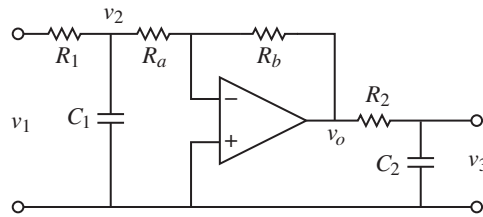

Show that the dynamics can be written in state space form as

$$\frac{dx}{dt} = \begin{pmatrix} -\frac{1}{R_1 C_1} - \frac{1}{R_a C_1} & 0 \\ \frac{R_b}{R_a} \frac{1}{R_2 C_2} & -\frac{1}{R_2 C_2} \end{pmatrix} x + \begin{pmatrix} \frac{1}{R_1 C_1} \\ 0 \end{pmatrix} u, \quad y = \begin{pmatrix} 0 & 1 \end{pmatrix} x,$$

where  $u = v_1$  and  $y = v_3$ . (Hint: Use  $v_2$  and  $v_3$  as your state variables.)

**4.5 (Operational amplifier oscillator)** The op amp circuit shown below is an implementation of an oscillator.

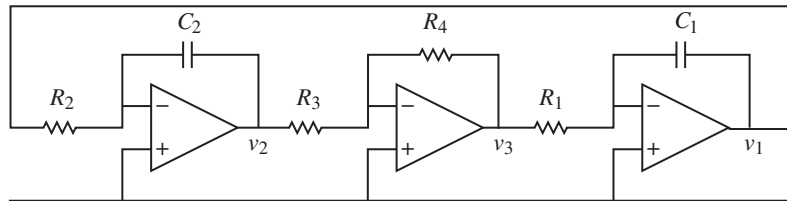

Show that the dynamics can be written in state space form as

$$\frac{dx}{dt} = \begin{pmatrix} 0 & \frac{R_4}{R_1 R_3 C_1} \\ -\frac{1}{R_2 C_2} & 0 \end{pmatrix} x,$$

where the state variables represent the voltages across the capacitors  $x_1 = v_1$  and  $x_2 = v_2$ .

**4.6** (Congestion control using RED [LPW+02]) A number of improvements can be made to the model for Internet congestion control presented in Section 4.4. To ensure that the router's buffer size remains positive, we can modify the buffer dynamics to satisfy

$$\frac{db_l}{dt} = \begin{cases} s_l - c_l & b_l > 0 \\ \text{sat}_{(0,\infty)}(s_l - c_l) & b_l = 0. \end{cases}$$

In addition, we can model the drop probability of a packet based on how close we are to the buffer limits, a mechanism known as random early detection (RED):

$$p_l = m_l(a_l) = \begin{cases} 0 & a_l(t) \leq b_l^{\text{lower}} \\ \rho_l r_l(t) - \rho_l b_l^{\text{lower}} & b_l^{\text{lower}} < a_l(t) < b_l^{\text{upper}} \\ \eta_l r_l(t) - (1 - 2b_l^{\text{upper}}) & b_l^{\text{upper}} \leq a_l(t) < 2b_l^{\text{upper}} \\ 1 & a_l(t) \geq 2b_l^{\text{upper}}, \end{cases}$$

$$\frac{da_l}{dt} = -\alpha_l c_l (a_l - b_l),$$

where  $\alpha_l$ ,  $b_l^{\text{upper}}$ ,  $b_l^{\text{lower}}$  and  $\rho_l^{\text{upper}}$  are parameters for the RED protocol.

Using the model above, write a simulation for the system and find a set of parameter values for which there is a stable equilibrium point and a set for which the system exhibits oscillatory solutions. The following sets of parameters should be explored:

$$\begin{aligned} N &= 20, 30, \dots, 60, & b_l^{\text{lower}} &= 40 \text{ pkts}, & \rho_l &= 0.1, \\ c &= 8, 9, \dots, 15 \text{ pkts/ms}, & b_l^{\text{upper}} &= 540 \text{ pkts}, & \alpha_l &= 10^{-4}, \\ \tau &= 55, 60, \dots, 100 \text{ ms}. \end{aligned}$$

**4.7** (Atomic force microscope with piezo tube) A schematic diagram of an AFM where the vertical scanner is a piezo tube with preloading is shown below.

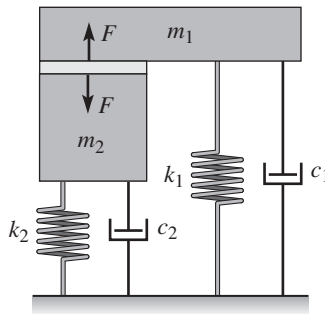

Show that the dynamics can be written as

$$(m_1 + m_2) \frac{d^2 z_1}{dt^2} + (c_1 + c_2) \frac{dz_1}{dt} + (k_1 + k_2) z_1 = m_2 \frac{d^2 l}{dt^2} + c_2 \frac{dl}{dt} + k_2 l.$$

Are there parameter values that make the dynamics particularly simple?

**4.8** (Drug administration) The metabolism of alcohol in the body can be modeled by the nonlinear compartment model

$$V_b \frac{dc_b}{dt} = q(c_l - c_b) + q_{iv}, \quad V_l \frac{dc_l}{dt} = q(c_b - c_l) - q_{\max} \frac{c_l}{c_0 + c_l} + q_{gi},$$

where  $V_b = 48$  L and  $V_l = 0.6$  L are the apparent volumes of distribution of body water and liver water,  $c_b$  and  $c_l$  are the concentrations of alcohol in the compartments,  $q_{iv}$  and  $q_{gi}$  are the injection rates for intravenous and gastrointestinal intake,  $q = 1.5$  L/min is the total hepatic blood flow,  $q_{\max} = 2.75$  mmol/min and  $c_0 = 0.1$  mmol/L. Simulate the system and compute the concentration in the blood for oral and intravenous doses of 12 g and 40 g of alcohol.

**4.9** (Population dynamics) Consider the model for logistic growth given by equation (4.30). Show that the maximum growth rate occurs when the size of the population is half of the steady-state value.

**4.10** (Fisheries management) The dynamics of a commercial fishery can be described by the following simple model:

$$\frac{dx}{dt} = f(x) - h(x, u), \quad y = bh(x, u) - cu,$$

where  $x$  is the total biomass,  $f(x) = rx(1 - x/k)$  is the growth rate and  $h(x, u) = axu$  is the harvesting rate. The output  $y$  is the rate of revenue, and the parameters  $a$ ,  $b$  and  $c$  are constants representing the price of fish and the cost of fishing. Show that there is an equilibrium where the steady-state biomass is  $x_e = c/(ab)$ . Compare with the situation when the biomass is regulated to a constant value and find the maximum sustainable return in that case.

---

## Chapter Five

### Dynamic Behavior

*It Don't Mean a Thing If It Ain't Got That Swing.*

Duke Ellington (1899–1974)

In this chapter we present a broad discussion of the behavior of dynamical systems focused on systems modeled by nonlinear differential equations. This allows us to consider equilibrium points, stability, limit cycles and other key concepts in understanding dynamic behavior. We also introduce some methods for analyzing the global behavior of solutions.

#### 5.1 Solving Differential Equations

In the previous two chapters we saw that one of the methods of modeling dynamical systems is through the use of ordinary differential equations (ODEs). A state space, input/output system has the form

$$\frac{dx}{dt} = f(x, u), \quad y = h(x, u), \quad (5.1)$$

where  $x = (x_1, \dots, x_n) \in \mathbb{R}^n$  is the state,  $u \in \mathbb{R}^p$  is the input and  $y \in \mathbb{R}^q$  is the output. The smooth maps  $f: \mathbb{R}^n \times \mathbb{R}^p \rightarrow \mathbb{R}^n$  and  $h: \mathbb{R}^n \times \mathbb{R}^p \rightarrow \mathbb{R}^q$  represent the dynamics and measurements for the system. In general, they can be nonlinear functions of their arguments. We will sometimes focus on single-input, single-output (SISO) systems, for which  $p = q = 1$ .

We begin by investigating systems in which the input has been set to a function of the state,  $u = \alpha(x)$ . This is one of the simplest types of feedback, in which the system regulates its own behavior. The differential equations in this case become

$$\frac{dx}{dt} = f(x, \alpha(x)) =: F(x). \quad (5.2)$$

To understand the dynamic behavior of this system, we need to analyze the features of the solutions of equation (5.2). While in some simple situations we can write down the solutions in analytical form, often we must rely on computational approaches. We begin by describing the class of solutions for this problem.

We say that  $x(t)$  is a *solution* of the differential equation (5.2) on the time interval  $t_0 \in \mathbb{R}$  to  $t_f \in \mathbb{R}$  if

$$\frac{dx(t)}{dt} = F(x(t)) \quad \text{for all } t_0 < t < t_f.$$

A given differential equation may have many solutions. We will most often be interested in the *initial value problem*, where  $x(t)$  is prescribed at a given time  $t_0 \in \mathbb{R}$  and we wish to find a solution valid for all *future* time  $t > t_0$ .

We say that  $x(t)$  is a solution of the differential equation (5.2) with initial value  $x_0 \in \mathbb{R}^n$  at  $t_0 \in \mathbb{R}$  if

$$x(t_0) = x_0 \quad \text{and} \quad \frac{dx(t)}{dt} = F(x(t)) \quad \text{for all } t_0 < t < t_f.$$

For most differential equations we will encounter, there is a *unique* solution that is defined for  $t_0 < t < t_f$ . The solution may be defined for all time  $t > t_0$ , in which case we take  $t_f = \infty$ . Because we will primarily be interested in solutions of the initial value problem for ODEs, we will usually refer to this simply as the solution of an ODE.

We will typically assume that  $t_0$  is equal to 0. In the case when  $F$  is independent of time (as in equation (5.2)), we can do so without loss of generality by choosing a new independent (time) variable,  $\tau = t - t_0$  (Exercise 5.1).

### Example 5.1 Damped oscillator

Consider a damped linear oscillator with dynamics of the form

$$\ddot{q} + 2\zeta\omega_0\dot{q} + \omega_0^2q = 0,$$

where  $q$  is the displacement of the oscillator from its rest position. These dynamics are equivalent to those of a spring–mass system, as shown in Exercise 3.6. We assume that  $\zeta < 1$ , corresponding to a lightly damped system (the reason for this particular choice will become clear later). We can rewrite this in state space form by setting  $x_1 = q$  and  $x_2 = \dot{q}/\omega_0$ , giving

$$\frac{dx_1}{dt} = \omega_0 x_2, \quad \frac{dx_2}{dt} = -\omega_0 x_1 - 2\zeta\omega_0 x_2.$$

In vector form, the right-hand side can be written as

$$F(x) = \begin{pmatrix} \omega_0 x_2 \\ -\omega_0 x_1 - 2\zeta\omega_0 x_2 \end{pmatrix}.$$

The solution to the initial value problem can be written in a number of different ways and will be explored in more detail in Chapter 6. Here we simply assert that the solution can be written as

$$\begin{aligned} x_1(t) &= e^{-\zeta\omega_0 t} \left( x_{10} \cos \omega_d t + \frac{1}{\omega_d} (\omega_0 \zeta x_{10} + x_{20}) \sin \omega_d t \right), \\ x_2(t) &= e^{-\zeta\omega_0 t} \left( x_{20} \cos \omega_d t - \frac{1}{\omega_d} (\omega_0^2 x_{10} + \omega_0 \zeta x_{20}) \sin \omega_d t \right), \end{aligned}$$

where  $x_0 = (x_{10}, x_{20})$  is the initial condition and  $\omega_d = \omega_0 \sqrt{1 - \zeta^2}$ . This solution can be verified by substituting it into the differential equation. We see that the solution is explicitly dependent on the initial condition, and it can be shown that this solution is unique. A plot of the initial condition response is shown in Figure 5.1.

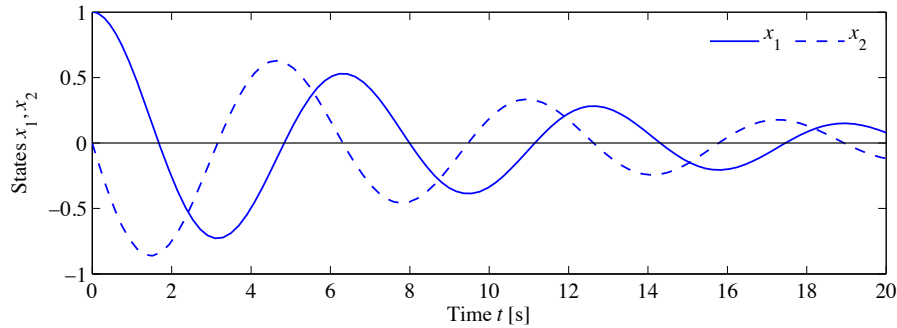

**Figure 5.1:** Response of the damped oscillator to the initial condition  $x_0 = (1, 0)$ . The solution is unique for the given initial conditions and consists of an oscillatory solution for each state, with an exponentially decaying magnitude.

We note that this form of the solution holds only for  $0 < \zeta < 1$ , corresponding to an “underdamped” oscillator.  $\nabla$

Without imposing some mathematical conditions on the function  $F$ , the differential equation (5.2) may not have a solution for all  $t$ , and there is no guarantee that the solution is unique. We illustrate these possibilities with two examples.  $\mathcal{N}$

### Example 5.2 Finite escape time

Let  $x \in \mathbb{R}$  and consider the differential equation

$$\frac{dx}{dt} = x^2 \quad (5.3)$$

with the initial condition  $x(0) = 1$ . By differentiation we can verify that the function

$$x(t) = \frac{1}{1-t}$$

satisfies the differential equation and that it also satisfies the initial condition. A graph of the solution is given in Figure 5.2a; notice that the solution goes to infinity as  $t$  goes to 1. We say that this system has *finite escape time*. Thus the solution exists only in the time interval  $0 \leq t < 1$ .  $\nabla$

### Example 5.3 Nonunique solution

Let  $x \in \mathbb{R}$  and consider the differential equation

$$\frac{dx}{dt} = 2\sqrt{x} \quad (5.4)$$

with initial condition  $x(0) = 0$ . We can show that the function

$$x(t) = \begin{cases} 0 & \text{if } 0 \leq t \leq a \\ (t-a)^2 & \text{if } t > a \end{cases}$$

satisfies the differential equation for all values of the parameter  $a \geq 0$ . To see this,

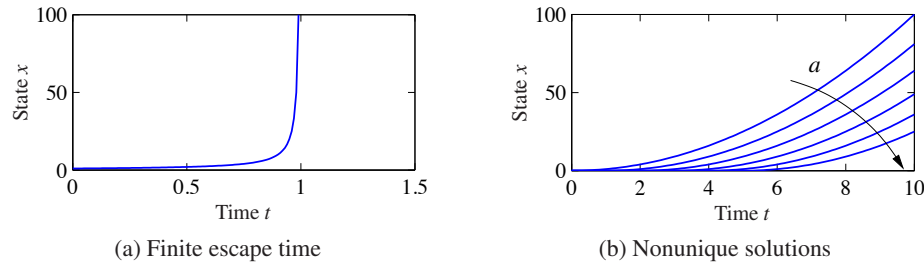

**Figure 5.2:** Existence and uniqueness of solutions. Equation (5.3) has a solution only for time  $t < 1$ , at which point the solution goes to  $\infty$ , as shown in (a). Equation (5.4) is an example of a system with many solutions, as shown in (b). For each value of  $a$ , we get a different solution starting from the same initial condition.

we differentiate  $x(t)$  to obtain

$$\frac{dx}{dt} = \begin{cases} 0 & \text{if } 0 \leq t \leq a \\ 2(t-a) & \text{if } t > a, \end{cases}$$

and hence  $\dot{x} = 2\sqrt{x}$  for all  $t \geq 0$  with  $x(0) = 0$ . A graph of some of the possible solutions is given in Figure 5.2b. Notice that in this case there are many solutions to the differential equation.  $\nabla$

These simple examples show that there may be difficulties even with simple differential equations. Existence and uniqueness can be guaranteed by requiring that the function  $F$  have the property that for some fixed  $c \in \mathbb{R}$ ,

$$\|F(x) - F(y)\| < c\|x - y\| \quad \text{for all } x, y,$$

which is called *Lipschitz continuity*. A sufficient condition for a function to be Lipschitz is that the Jacobian  $\partial F/\partial x$  is uniformly bounded for all  $x$ . The difficulty in Example 5.2 is that the derivative  $\partial F/\partial x$  becomes large for large  $x$ , and the difficulty in Example 5.3 is that the derivative  $\partial F/\partial x$  is infinite at the origin.

## 5.2 Qualitative Analysis

The qualitative behavior of nonlinear systems is important in understanding some of the key concepts of stability in nonlinear dynamics. We will focus on an important class of systems known as planar dynamical systems. These systems have two state variables  $x \in \mathbb{R}^2$ , allowing their solutions to be plotted in the  $(x_1, x_2)$  plane. The basic concepts that we describe hold more generally and can be used to understand dynamical behavior in higher dimensions.

### Phase Portraits

A convenient way to understand the behavior of dynamical systems with state  $x \in \mathbb{R}^2$  is to plot the phase portrait of the system, briefly introduced in Chapter 3.



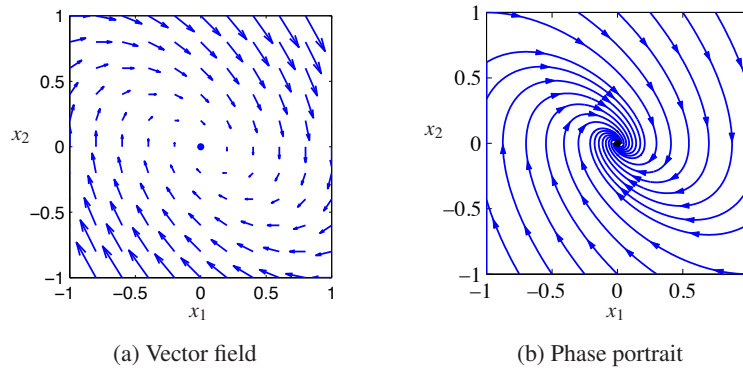

**Figure 5.3:** Phase portraits. (a) This plot shows the vector field for a planar dynamical system. Each arrow shows the velocity at that point in the state space. (b) This plot includes the solutions (sometimes called streamlines) from different initial conditions, with the vector field superimposed.

We start by introducing the concept of a *vector field*. For a system of ordinary differential equations

$$\frac{dx}{dt} = F(x),$$

the right-hand side of the differential equation defines at every  $x \in \mathbb{R}^n$  a velocity  $F(x) \in \mathbb{R}^n$ . This velocity tells us how  $x$  changes and can be represented as a vector  $F(x) \in \mathbb{R}^n$ .

For planar dynamical systems, each state corresponds to a point in the plane and  $F(x)$  is a vector representing the velocity of that state. We can plot these vectors on a grid of points in the plane and obtain a visual image of the dynamics of the system, as shown in Figure 5.3a. The points where the velocities are zero are of particular interest since they define stationary points of the flow: if we start at such a state, we stay at that state.

A *phase portrait* is constructed by plotting the flow of the vector field corresponding to the planar dynamical system. That is, for a set of initial conditions, we plot the solution of the differential equation in the plane  $\mathbb{R}^2$ . This corresponds to following the arrows at each point in the phase plane and drawing the resulting trajectory. By plotting the solutions for several different initial conditions, we obtain a phase portrait, as shown in Figure 5.3b. Phase portraits are also sometimes called *phase plane diagrams*.

Phase portraits give insight into the dynamics of the system by showing the solutions plotted in the (two-dimensional) state space of the system. For example, we can see whether all trajectories tend to a single point as time increases or whether there are more complicated behaviors. In the example in Figure 5.3, corresponding to a damped oscillator, the solutions approach the origin for all initial conditions. This is consistent with our simulation in Figure 5.1, but it allows us to infer the behavior for all initial conditions rather than a single initial condition. However, the phase portrait does not readily tell us the rate of change of the states (although

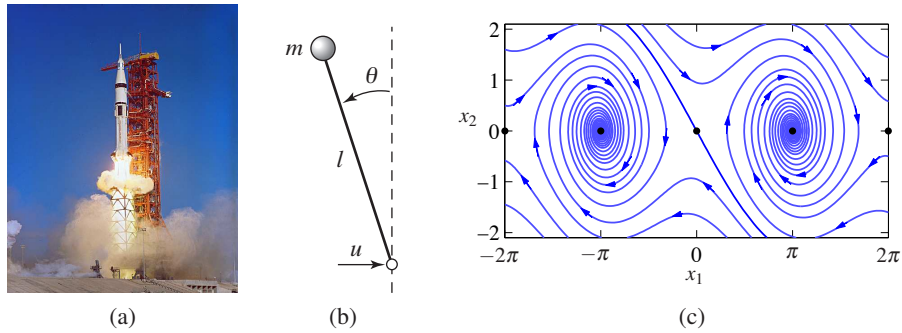

**Figure 5.4:** Equilibrium points for an inverted pendulum. An inverted pendulum is a model for a class of balance systems in which we wish to keep a system upright, such as a rocket (a). Using a simplified model of an inverted pendulum (b), we can develop a phase portrait that shows the dynamics of the system (c). The system has multiple equilibrium points, marked by the solid dots along the  $x_2 = 0$  line.

this can be inferred from the lengths of the arrows in the vector field plot).

### Equilibrium Points and Limit Cycles

An *equilibrium point* of a dynamical system represents a stationary condition for the dynamics. We say that a state  $x_e$  is an equilibrium point for a dynamical system

$$\frac{dx}{dt} = F(x)$$

if  $F(x_e) = 0$ . If a dynamical system has an initial condition  $x(0) = x_e$ , then it will stay at the equilibrium point:  $x(t) = x_e$  for all  $t \geq 0$ , where we have taken  $t_0 = 0$ .

Equilibrium points are one of the most important features of a dynamical system since they define the states corresponding to constant operating conditions. A dynamical system can have zero, one or more equilibrium points.

#### Example 5.4 Inverted pendulum

Consider the inverted pendulum in Figure 5.4, which is a part of the balance system we considered in Chapter 3. The inverted pendulum is a simplified version of the problem of stabilizing a rocket: by applying forces at the base of the rocket, we seek to keep the rocket stabilized in the upright position. The state variables are the angle  $\theta = x_1$  and the angular velocity  $d\theta/dt = x_2$ , the control variable is the acceleration  $u$  of the pivot and the output is the angle  $\theta$ .

For simplicity we assume that  $mg l/J_t = 1$ ,  $l/J_t = 1$  and set  $c = \gamma/J_t$ , so that the dynamics (equation (3.10)) become

$$\frac{dx}{dt} = \begin{pmatrix} x_2 \\ \sin x_1 - c x_2 + u \cos x_1 \end{pmatrix}. \quad (5.5)$$

This is a nonlinear time-invariant system of second order. This same set of equations can also be obtained by appropriate normalization of the system dynamics as illustrated in Example 3.9.

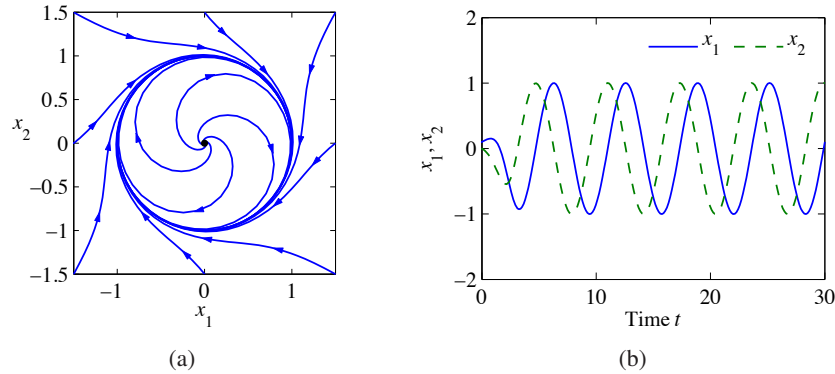

**Figure 5.5:** Phase portrait and time domain simulation for a system with a limit cycle. The phase portrait (a) shows the states of the solution plotted for different initial conditions. The limit cycle corresponds to a closed loop trajectory. The simulation (b) shows a single solution plotted as a function of time, with the limit cycle corresponding to a steady oscillation of fixed amplitude.

We consider the open loop dynamics by setting  $u = 0$ . The equilibrium points for the system are given by

$$x_e = \begin{pmatrix} \pm n\pi \\ 0 \end{pmatrix},$$

where  $n = 0, 1, 2, \dots$ . The equilibrium points for  $n$  even correspond to the pendulum pointing up and those for  $n$  odd correspond to the pendulum hanging down. A phase portrait for this system (without corrective inputs) is shown in Figure 5.4c. The phase portrait shows  $-2\pi \leq x_1 \leq 2\pi$ , so five of the equilibrium points are shown.  $\nabla$

Nonlinear systems can exhibit rich behavior. Apart from equilibria they can also exhibit stationary periodic solutions. This is of great practical value in generating sinusoidally varying voltages in power systems or in generating periodic signals for animal locomotion. A simple example is given in Exercise 5.12, which shows the circuit diagram for an electronic oscillator. A normalized model of the oscillator is given by the equation

$$\frac{dx_1}{dt} = x_2 + x_1(1 - x_1^2 - x_2^2), \quad \frac{dx_2}{dt} = -x_1 + x_2(1 - x_1^2 - x_2^2). \quad (5.6)$$

The phase portrait and time domain solutions are given in Figure 5.5. The figure shows that the solutions in the phase plane converge to a circular trajectory. In the time domain this corresponds to an oscillatory solution. Mathematically the circle is called a *limit cycle*. More formally, we call a nonconstant solution  $x(t)$  a limit cycle of period  $T > 0$  if  $x(t+T) = x(t)$  for all  $t \in \mathbb{R}$ .

There are methods for determining limit cycles for second-order systems, but for general higher-order systems we have to resort to computational analysis. Computer algorithms find limit cycles by searching for periodic trajectories in state

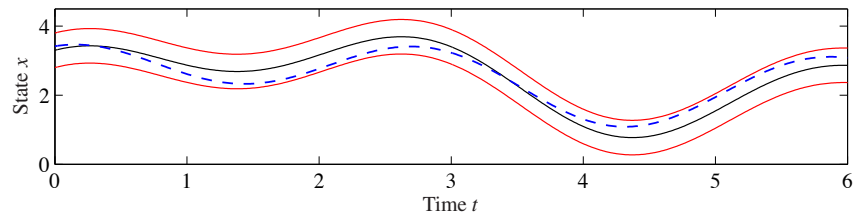

**Figure 5.6:** Illustration of Lyapunov's concept of a stable solution. The solution represented by the solid line is stable if we can guarantee that all solutions remain within a tube of diameter  $\varepsilon$  by choosing initial conditions sufficiently close the solution.

space that satisfy the dynamics of the system. In many situations, stable limit cycles can be found by simulating the system with different initial conditions.

### 5.3 Stability

The stability of a solution determines whether or not solutions nearby the solution remain close, get closer or move further away. We now give a formal definition of stability and describe tests for determining whether a solution is stable.

#### Definitions

Let  $x(t; a)$  be a solution to the differential equation with initial condition  $a$ . A solution is *stable* if other solutions that start near  $a$  stay close to  $x(t; a)$ . Formally, we say that the solution  $x(t; a)$  is stable if for all  $\varepsilon > 0$ , there exists a  $\delta > 0$  such that

$$\|b - a\| < \delta \implies \|x(t; b) - x(t; a)\| < \varepsilon \quad \text{for all } t > 0.$$

Note that this definition does not imply that  $x(t; b)$  approaches  $x(t; a)$  as time increases but just that it stays nearby. Furthermore, the value of  $\delta$  may depend on  $\varepsilon$ , so that if we wish to stay very close to the solution, we may have to start very, very close ( $\delta \ll \varepsilon$ ). This type of stability, which is illustrated in Figure 5.6, is also called *stability in the sense of Lyapunov*. If a solution is stable in this sense and the trajectories do not converge, we say that the solution is *neutrally stable*.

An important special case is when the solution  $x(t; a) = x_e$  is an equilibrium solution. Instead of saying that the solution is stable, we simply say that the equilibrium point is stable. An example of a neutrally stable equilibrium point is shown in Figure 5.7. From the phase portrait, we see that if we start near the equilibrium point, then we stay near the equilibrium point. Indeed, for this example, given any  $\varepsilon$  that defines the range of possible initial conditions, we can simply choose  $\delta = \varepsilon$  to satisfy the definition of stability since the trajectories are perfect circles.

A solution  $x(t; a)$  is *asymptotically stable* if it is stable in the sense of Lyapunov and also  $x(t; b)$  approaches  $x(t; a)$  as  $t$  approaches  $\infty$  for  $b$  sufficiently close to  $a$ . Hence, the solution  $x(t; a)$  is asymptotically stable if for every  $\varepsilon > 0$  there exists a

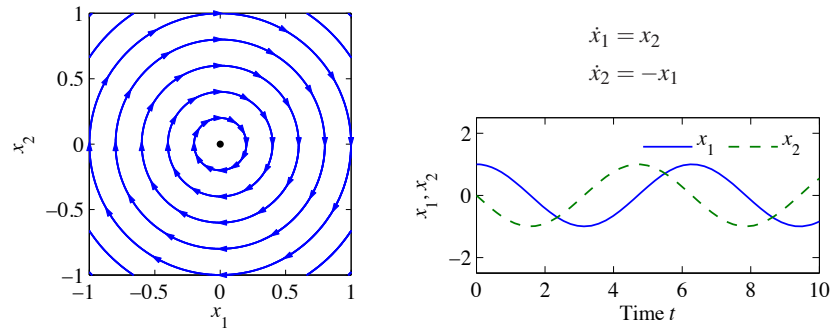

**Figure 5.7:** Phase portrait and time domain simulation for a system with a single stable equilibrium point. The equilibrium point  $x_e$  at the origin is stable since all trajectories that start near  $x_e$  stay near  $x_e$ .

$\delta > 0$  such that

$$\|b - a\| < \delta \implies \|x(t; b) - x(t; a)\| < \varepsilon \text{ and } \lim_{t \rightarrow \infty} \|x(t; b) - x(t; a)\| = 0.$$

This corresponds to the case where all nearby trajectories converge to the stable solution for large time. Figure 5.8 shows an example of an asymptotically stable equilibrium point. Indeed, as seen in the phase portrait, not only do all trajectories stay near the equilibrium point at the origin, but they also all approach the origin as  $t$  gets large (the directions of the arrows on the phase portrait show the direction in which the trajectories move).

A solution  $x(t; a)$  is *unstable* if it is not stable. More specifically, we say that a solution  $x(t; a)$  is unstable if given some  $\varepsilon > 0$ , there does *not* exist a  $\delta > 0$  such that if  $\|b - a\| < \delta$ , then  $\|x(t; b) - x(t; a)\| < \varepsilon$  for all  $t$ . An example of an unstable equilibrium point is shown in Figure 5.9.

The definitions above are given without careful description of their domain of applicability. More formally, we define a solution to be *locally stable* (or *locally*

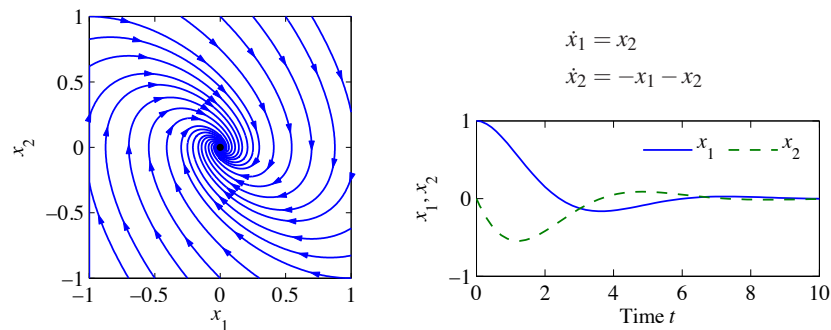

**Figure 5.8:** Phase portrait and time domain simulation for a system with a single asymptotically stable equilibrium point. The equilibrium point  $x_e$  at the origin is asymptotically stable since the trajectories converge to this point as  $t \rightarrow \infty$ .

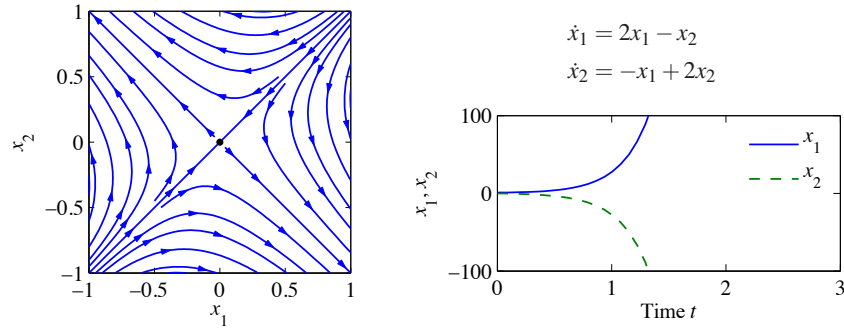

**Figure 5.9:** Phase portrait and time domain simulation for a system with a single unstable equilibrium point. The equilibrium point  $x_e$  at the origin is unstable since not all trajectories that start near  $x_e$  stay near  $x_e$ . The sample trajectory on the right shows that the trajectories very quickly depart from zero.

*asymptotically stable*) if it is stable for all initial conditions  $x \in B_r(a)$ , where

$$B_r(a) = \{x : \|x - a\| < r\}$$

is a ball of radius  $r$  around  $a$  and  $r > 0$ . A solution is *globally asymptotically stable* if it is asymptotically stable for all  $r > 0$ .

For planar dynamical systems, equilibrium points have been assigned names based on their stability type. An asymptotically stable equilibrium point is called a *sink* or sometimes an *attractor*. An unstable equilibrium point can be either a *source*, if all trajectories lead away from the equilibrium point, or a *saddle*, if some trajectories lead to the equilibrium point and others move away (this is the situation pictured in Figure 5.9). Finally, an equilibrium point that is stable but not asymptotically stable (i.e., neutrally stable, such as the one in Figure 5.7) is called a *center*.

### Example 5.5 Congestion control

The model for congestion control in a network consisting of  $N$  identical computers connected to a single router, described in more detail in Section 4.4, is given by

$$\frac{dw}{dt} = \frac{c}{b} - \rho c \left(1 + \frac{w^2}{2}\right), \quad \frac{db}{dt} = N \frac{wc}{b} - c,$$

where  $w$  is the window size and  $b$  is the buffer size of the router. The equilibrium points are given by

$$b = Nw \quad \text{with} \quad w \left(1 + \frac{w^2}{2}\right) = \frac{\rho}{N}.$$

Phase portraits are shown in Figure 5.10 for two different sets of parameter values. In each case we see that the system converges to an equilibrium point in which the buffer is below its full capacity of 500 packets. The equilibrium size of the buffer represents a balance between the transmission rates for the sources and the

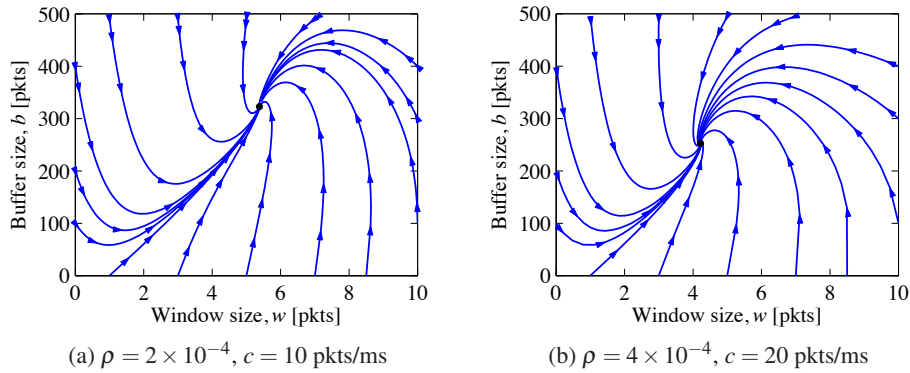

**Figure 5.10:** Phase portraits for a congestion control protocol running with  $N = 60$  identical source computers. The equilibrium values correspond to a fixed window at the source, which results in a steady-state buffer size and corresponding transmission rate. A faster link (b) uses a smaller buffer size since it can handle packets at a higher rate.

capacity of the link. We see from the phase portraits that the equilibrium points are asymptotically stable since all initial conditions result in trajectories that converge to these points.  $\nabla$

### Stability of Linear Systems

A linear dynamical system has the form

$$\frac{dx}{dt} = Ax, \quad x(0) = x_0, \quad (5.7)$$

where  $A \in \mathbb{R}^{n \times n}$  is a square matrix, corresponding to the dynamics matrix of a linear control system (3.6). For a linear system, the stability of the equilibrium at the origin can be determined from the eigenvalues of the matrix  $A$ :

$$\lambda(A) := \{s \in \mathbb{C} : \det(sI - A) = 0\}.$$

The polynomial  $\det(sI - A)$  is the *characteristic polynomial* and the eigenvalues are its roots. We use the notation  $\lambda_j$  for the  $j$ th eigenvalue of  $A$ , so that  $\lambda_j \in \lambda(A)$ . In general  $\lambda$  can be complex-valued, although if  $A$  is real-valued, then for any eigenvalue  $\lambda$ , its complex conjugate  $\lambda^*$  will also be an eigenvalue. The origin is always an equilibrium for a linear system. Since the stability of a linear system depends only on the matrix  $A$ , we find that stability is a property of the system. For a linear system we can therefore talk about the stability of the system rather than the stability of a particular solution or equilibrium point.

The easiest class of linear systems to analyze are those whose system matrices

are in diagonal form. In this case, the dynamics have the form

$$\frac{dx}{dt} = \begin{pmatrix} \lambda_1 & & & 0 \\ & \lambda_2 & & \\ & & \ddots & \\ 0 & & & \lambda_n \end{pmatrix} x. \quad (5.8)$$

It is easy to see that the state trajectories for this system are independent of each other, so that we can write the solution in terms of  $n$  individual systems  $\dot{x}_j = \lambda_j x_j$ . Each of these scalar solutions is of the form

$$x_j(t) = e^{\lambda_j t} x_j(0).$$

We see that the equilibrium point  $x_e = 0$  is stable if  $\lambda_j \leq 0$  and asymptotically stable if  $\lambda_j < 0$ .

Another simple case is when the dynamics are in the block diagonal form

$$\frac{dx}{dt} = \begin{pmatrix} \sigma_1 & \omega_1 & & 0 & 0 \\ -\omega_1 & \sigma_1 & & 0 & 0 \\ & & \ddots & \vdots & \vdots \\ 0 & 0 & & \sigma_m & \omega_m \\ 0 & 0 & & -\omega_m & \sigma_m \end{pmatrix} x.$$

In this case, the eigenvalues can be shown to be  $\lambda_j = \sigma_j \pm i\omega_j$ . We once again can separate the state trajectories into independent solutions for each pair of states, and the solutions are of the form

$$\begin{aligned} x_{2j-1}(t) &= e^{\sigma_j t} (x_{2j-1}(0) \cos \omega_j t + x_{2j}(0) \sin \omega_j t), \\ x_{2j}(t) &= e^{\sigma_j t} (-x_{2j-1}(0) \sin \omega_j t + x_{2j}(0) \cos \omega_j t), \end{aligned}$$

where  $j = 1, 2, \dots, m$ . We see that this system is asymptotically stable if and only if  $\sigma_j = \text{Re } \lambda_j < 0$ . It is also possible to combine real and complex eigenvalues in (block) diagonal form, resulting in a mixture of solutions of the two types.

Very few systems are in one of the diagonal forms above, but many systems can be transformed into these forms via coordinate transformations. One such class of systems is those for which the dynamics matrix has distinct (nonrepeating) eigenvalues. In this case there is a matrix  $T \in \mathbb{R}^{n \times n}$  such that the matrix  $TAT^{-1}$  is in (block) diagonal form, with the block diagonal elements corresponding to the eigenvalues of the original matrix  $A$  (see Exercise 5.14). If we choose new coordinates  $z = Tx$ , then

$$\frac{dz}{dt} = T\dot{x} = TAx = TAT^{-1}z$$

and the linear system has a (block) diagonal dynamics matrix. Furthermore, the eigenvalues of the transformed system are the same as those of the original system since if  $v$  is an eigenvector of  $A$ , then  $w = Tv$  can be shown to be an eigenvector of  $TAT^{-1}$ . We can reason about the stability of the original system by noting that  $x(t) = T^{-1}z(t)$ , and so if the transformed system is stable (or asymptotically



stable), then the original system has the same type of stability.

This analysis shows that for linear systems with distinct eigenvalues, the stability of the system can be completely determined by examining the real part of the eigenvalues of the dynamics matrix. For more general systems, we make use of the following theorem, proved in the next chapter:

**Theorem 5.1** (Stability of a linear system). *The system*

$$\frac{dx}{dt} = Ax$$

*is asymptotically stable if and only if all eigenvalues of  $A$  all have a strictly negative real part and is unstable if any eigenvalue of  $A$  has a strictly positive real part.*

Note that it is not enough to have eigenvalues with  $\text{Re}(\lambda) \leq 0$ . As a simple example, consider the system  $\ddot{q} = 0$ , which can be written in state space form as

$$\frac{d}{dt} \begin{pmatrix} x_1 \\ x_2 \end{pmatrix} = \begin{pmatrix} 0 & 1 \\ 0 & 0 \end{pmatrix} \begin{pmatrix} x_1 \\ x_2 \end{pmatrix}.$$

The system has eigenvalues  $\lambda = 0$  but the solutions are not bounded since we have

$$x_1(t) = x_{1,0} + x_{2,0}t, \quad x_2(t) = x_{2,0}.$$

### Example 5.6 Compartment model

Consider the two-compartment module for drug delivery described in Section 4.6. Using concentrations as state variables and denoting the state vector by  $x$ , the system dynamics are given by

$$\frac{dx}{dt} = \begin{pmatrix} -k_0 - k_1 & k_1 \\ k_2 & -k_2 \end{pmatrix} x + \begin{pmatrix} b_0 \\ 0 \end{pmatrix} u, \quad y = \begin{pmatrix} 0 & 1 \end{pmatrix} x,$$

where the input  $u$  is the rate of injection of a drug into compartment 1 and the concentration of the drug in compartment 2 is the measured output  $y$ . We wish to design a feedback control law that maintains a constant output given by  $y = y_d$ .

We choose an output feedback control law of the form

$$u = -k(y - y_d) + u_d,$$

where  $u_d$  is the rate of injection required to maintain the desired concentration and  $k$  is a feedback gain that should be chosen such that the closed loop system is stable. Substituting the control law into the system, we obtain

$$\begin{aligned} \frac{dx}{dt} &= \begin{pmatrix} -k_0 - k_1 & k_1 - b_0k \\ k_2 & -k_2 \end{pmatrix} x + \begin{pmatrix} b_0 \\ 0 \end{pmatrix} (u_d + ky_d) =: Ax + Bu_e, \\ y &= \begin{pmatrix} 0 & 1 \end{pmatrix} x =: Cx. \end{aligned}$$

The equilibrium concentration  $x_e \in \mathbb{R}^2$  is given by  $x_e = -A^{-1}Bu_e$  and

$$y_e = -CA^{-1}Bu_e = \frac{b_0k_2}{k_0k_2 + b_0k_2k} (u_d + ky_d).$$

Choosing  $u_d$  such that  $y_e = y_d$  provides the constant rate of injection required to maintain the desired output. We can now shift coordinates to place the equilibrium point at the origin, which yields (after some algebra)

$$\frac{dz}{dt} = \begin{pmatrix} -k_0 - k_1 & k_1 - b_0k \\ k_2 & -k_2 \end{pmatrix} z,$$

where  $z = x - x_e$ . We can now apply the results of Theorem 5.1 to determine the stability of the system. The eigenvalues of the system are given by the roots of the characteristic polynomial

$$\lambda(s) = s^2 + (k_0 + k_1 + k_2)s + (k_0k_2 + b_0k_2k).$$

While the specific form of the roots is messy, it can be shown that the roots have negative real part as long as the linear term and the constant term are both positive (Exercise 5.16). Hence the system is stable for any  $k > 0$ .  $\nabla$

### Stability Analysis via Linear Approximation

An important feature of differential equations is that it is often possible to determine the local stability of an equilibrium point by approximating the system by a linear system. The following example illustrates the basic idea.

#### Example 5.7 Inverted pendulum

Consider again an inverted pendulum whose open loop dynamics are given by

$$\frac{dx}{dt} = \begin{pmatrix} x_2 \\ \sin x_1 - \gamma x_2 \end{pmatrix},$$

where we have defined the state as  $x = (\theta, \dot{\theta})$ . We first consider the equilibrium point at  $x = (0, 0)$ , corresponding to the straight-up position. If we assume that the angle  $\theta = x_1$  remains small, then we can replace  $\sin x_1$  with  $x_1$  and  $\cos x_1$  with 1, which gives the approximate system

$$\frac{dx}{dt} = \begin{pmatrix} x_2 \\ x_1 - \gamma x_2 \end{pmatrix} = \begin{pmatrix} 0 & 1 \\ 1 & -\gamma \end{pmatrix} x. \quad (5.9)$$

Intuitively, this system should behave similarly to the more complicated model as long as  $x_1$  is small. In particular, it can be verified that the equilibrium point  $(0, 0)$  is unstable by plotting the phase portrait or computing the eigenvalues of the dynamics matrix in equation (5.9)

We can also approximate the system around the stable equilibrium point at  $x = (\pi, 0)$ . In this case we have to expand  $\sin x_1$  and  $\cos x_1$  around  $x_1 = \pi$ , according to the expansions

$$\sin(\pi + \theta) = -\sin \theta \approx -\theta, \quad \cos(\pi + \theta) = -\cos(\theta) \approx -1.$$

If we define  $z_1 = x_1 - \pi$  and  $z_2 = x_2$ , the resulting approximate dynamics are given by

$$\frac{dz}{dt} = \begin{pmatrix} z_2 \\ -z_1 - \gamma z_2 \end{pmatrix} = \begin{pmatrix} 0 & 1 \\ -1 & -\gamma \end{pmatrix} z. \quad (5.10)$$

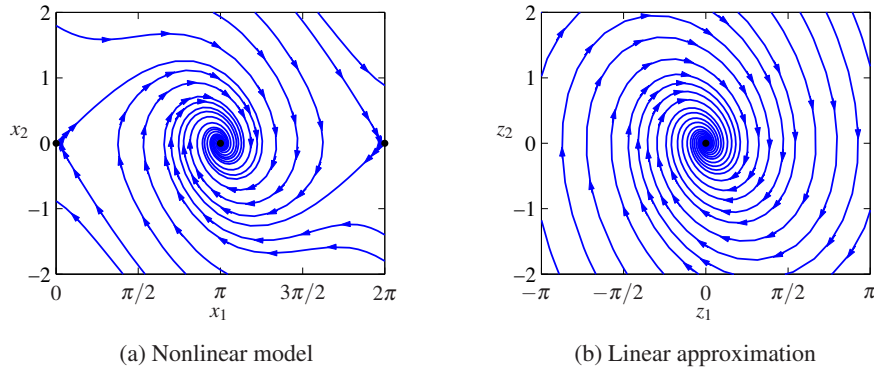

**Figure 5.11:** Comparison between the phase portraits for the full nonlinear systems (a) and its linear approximation around the origin (b). Notice that near the equilibrium point at the center of the plots, the phase portraits (and hence the dynamics) are almost identical.

Figure 5.11 shows the phase portraits for the original system and the approximate system around the corresponding equilibrium points. Note that  $z = (0, 0)$  is the equilibrium point for this system and that it has the same basic form as the dynamics shown in Figure 5.8. The solutions for the original system and the approximate are very similar, although not exactly the same. It can be shown that if a linear approximation has either asymptotically stable or unstable equilibrium points, then the local stability of the original system must be the same (see Theorem 5.3 on page 5-23 for the case of asymptotic stability).  $\nabla$

More generally, suppose that we have a nonlinear system

$$\frac{dx}{dt} = F(x)$$

that has an equilibrium point at  $x_e$ . Computing the Taylor series expansion of the vector field, we can write

$$\frac{dx}{dt} = F(x_e) + \left. \frac{\partial F}{\partial x} \right|_{x_e} (x - x_e) + \text{higher-order terms in } (x - x_e).$$

Since  $F(x_e) = 0$ , we can approximate the system by choosing a new state variable  $z = x - x_e$  and writing

$$\frac{dz}{dt} = Az, \quad \text{where } A = \left. \frac{\partial F}{\partial x} \right|_{x_e}. \quad (5.11)$$

We call the system (5.11) the *linear approximation* of the original nonlinear system or the *linearization* at  $x_e$ .

The fact that a linear model can be used to study the behavior of a nonlinear system near an equilibrium point is a powerful one. Indeed, we can take this even further and use a local linear approximation of a nonlinear system to design a feedback law that keeps the system near its equilibrium point (design of dynamics). Thus, feedback can be used to make sure that solutions remain close to

the equilibrium point, which in turn ensures that the linear approximation used to stabilize it is valid.

Linear approximations can also be used to understand the stability of nonequilibrium solutions, as illustrated by the following example.

**Example 5.8 Stability of limit cycles**

Consider the system given by equation (5.6),

$$\frac{dx_1}{dt} = x_2 + x_1(1 - x_1^2 - x_2^2), \quad \frac{dx_2}{dt} = -x_1 + x_2(1 - x_1^2 - x_2^2),$$

whose phase portrait is shown in Figure 5.5. The differential equation has a periodic solution

$$x_1(t) = x_1(0) \cos t + x_2(0) \sin t, \quad (5.12)$$

with  $x_1^2(0) + x_2^2(0) = 1$ .

To explore the stability of this solution, we introduce polar coordinates  $r$  and  $\varphi$ , which are related to the state variables  $x_1$  and  $x_2$  by

$$x_1 = r \cos \varphi, \quad x_2 = r \sin \varphi.$$

Differentiation gives the following linear equations for  $\dot{r}$  and  $\dot{\varphi}$ :

$$\dot{x}_1 = \dot{r} \cos \varphi - r \dot{\varphi} \sin \varphi, \quad \dot{x}_2 = \dot{r} \sin \varphi + r \dot{\varphi} \cos \varphi.$$

Solving this linear system for  $\dot{r}$  and  $\dot{\varphi}$  gives, after some calculation,

$$\frac{dr}{dt} = r(1 - r^2), \quad \frac{d\varphi}{dt} = -1. \quad (5.13)$$

Notice that the equations are decoupled; hence we can analyze the stability of each state separately.

The equation for  $r$  has three equilibria:  $r = 0$ ,  $r = 1$  and  $r = -1$  (not realizable since  $r$  must be positive). We can analyze the stability of these equilibria by linearizing the radial dynamics with  $F(r) = r(1 - r^2)$ . The corresponding linear dynamics are given by

$$\frac{d\tilde{r}}{dt} = \left. \frac{\partial F}{\partial r} \right|_{r_e} \tilde{r} = (1 - 3r_e^2)\tilde{r}, \quad r_e = 0, 1,$$

where  $\tilde{r} = r - r_e$  represents the deviation from the equilibrium point. It follows from the sign of  $(1 - 3r_e^2)$  that the equilibrium  $r = 0$  is unstable and the equilibrium  $r = 1$  is asymptotically stable for equation (5.13). Thus for any initial condition  $r > 0$  the solution goes to  $r = 1$  as time goes to infinity, but if the system starts with  $r = 0$ , it will remain at the equilibrium for all times. This implies that all solutions to the original system that do not start at  $x_1 = x_2 = 0$  will approach the circle  $x_1^2 + x_2^2 = 1$  as time increases.

To show the stability of the full solution (5.12), we must investigate the behavior of neighboring solutions with different initial conditions. We have already shown that the radius  $r$  will approach that of the solution (5.12) as long as  $r(0) > 0$ . The equation for the angle  $\varphi$  can be integrated analytically to give  $\varphi(t) = -t +$

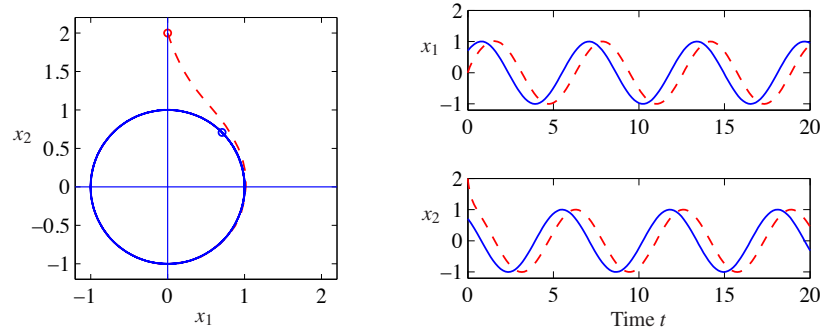

**Figure 5.12:** Solution curves for a stable limit cycle. The phase portrait on the left shows that the trajectory for the system rapidly converges to the stable limit cycle. The starting points for the trajectories are marked by circles in the phase portrait. The time domain plots on the right show that the states do not converge to the solution but instead maintain a constant phase error.

$\varphi(0)$ , which shows that solutions starting at different angles  $\varphi$  will neither converge nor diverge. Thus, the unit circle is *attracting*, but the solution (5.12) is only stable, not asymptotically stable. The behavior of the system is illustrated by the simulation in Figure 5.12. Notice that the solutions approach the circle rapidly, but that there is a constant phase shift between the solutions.  $\nabla$

## 5.4 Lyapunov Stability Analysis



We now return to the study of the full nonlinear system

$$\frac{dx}{dt} = F(x), \quad x \in \mathbb{R}^n. \quad (5.14)$$

Having defined when a solution for a nonlinear dynamical system is stable, we can now ask how to prove that a given solution is stable, asymptotically stable or unstable. For physical systems, one can often argue about stability based on dissipation of energy. The generalization of that technique to arbitrary dynamical systems is based on the use of Lyapunov functions in place of energy.

In this section we will describe techniques for determining the stability of solutions for a nonlinear system (5.14). We will generally be interested in stability of equilibrium points, and it will be convenient to assume that  $x_e = 0$  is the equilibrium point of interest. (If not, rewrite the equations in a new set of coordinates  $z = x - x_e$ .)

### Lyapunov Functions

A *Lyapunov function*  $V : \mathbb{R}^n \rightarrow \mathbb{R}$  is an energy-like function that can be used to determine the stability of a system. Roughly speaking, if we can find a nonnegative function that always decreases along trajectories of the system, we can conclude that the minimum of the function is a stable equilibrium point (locally).

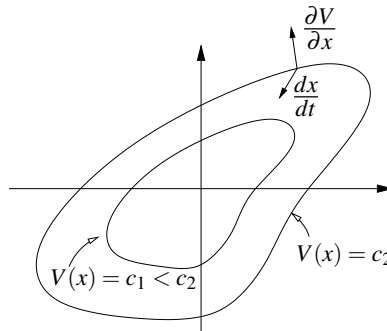

**Figure 5.13:** Geometric illustration of Lyapunov's stability theorem. The closed contours represent the level sets of the Lyapunov function  $V(x) = c$ . If  $dx/dt$  points inward to these sets at all points along the contour, then the trajectories of the system will always cause  $V(x)$  to decrease along the trajectory.

To describe this more formally, we start with a few definitions. Let  $B_r = B_r(0)$  be a ball of radius  $r$  around the origin. We say that a continuous function  $V$  is *positive definite* on  $B_r$  if  $V(x) > 0$  for all  $x \in B_r, x \neq 0$  and  $V(0) = 0$ . Similarly, a function is *negative definite* on  $B_r$  if  $V(x) < 0$  for all  $x \in B_r, x \neq 0$  and  $V(0) = 0$ . We say that a function  $V$  is *positive semidefinite* if  $V(x) \geq 0$  for all  $x \in B_r$ , but  $V(x)$  can be zero at points other than just  $x = 0$ .

To illustrate the difference between a positive definite function and a positive semidefinite function, suppose that  $x \in \mathbb{R}^2$  and let

$$V_1(x) = x_1^2, \quad V_2(x) = x_1^2 + x_2^2.$$

Both  $V_1$  and  $V_2$  are always nonnegative. However, it is possible for  $V_1$  to be zero even if  $x \neq 0$ . Specifically, if we set  $x = (0, c)$ , where  $c \in \mathbb{R}$  is any nonzero number, then  $V_1(x) = 0$ . On the other hand,  $V_2(x) = 0$  if and only if  $x = (0, 0)$ . Thus  $V_1$  is positive semidefinite and  $V_2$  is positive definite.

We can now characterize the stability of an equilibrium point  $x_e = 0$  for the system (5.14).

**Theorem 5.2** (Lyapunov stability theorem). *Let  $V$  be a function on  $\mathbb{R}^n$  and let  $\dot{V}$  represent the time derivative of  $V$  along trajectories of the system dynamics (5.14):*

$$\dot{V} = \frac{\partial V}{\partial x} \frac{dx}{dt} = \frac{\partial V}{\partial x} F(x).$$

*If there exists  $r > 0$  such that  $V$  is positive definite and  $\dot{V}$  is negative semidefinite on  $B_r$ , then  $x = 0$  is (locally) stable in the sense of Lyapunov. If  $V$  is positive definite and  $\dot{V}$  is negative definite in  $B_r$ , then  $x = 0$  is (locally) asymptotically stable.*

If  $V$  satisfies one of the conditions above, we say that  $V$  is a (local) *Lyapunov function* for the system. These results have a nice geometric interpretation. The level curves for a positive definite function are the curves defined by  $V(x) = c$ ,  $c > 0$ , and for each  $c$  this gives a closed contour, as shown in Figure 5.13. The condition that  $\dot{V}(x)$  is negative simply means that the vector field points toward

lower-level contours. This means that the trajectories move to smaller and smaller values of  $V$  and if  $\dot{V}$  is negative definite then  $x$  must approach 0.

Finding Lyapunov functions is not always easy. For example, consider the linear system

$$\frac{dx_1}{dt} = x_2, \quad \frac{dx_2}{dt} = -\alpha x_2.$$

### Example 5.9 Scalar nonlinear system

Consider the scalar nonlinear system

$$\frac{dx}{dt} = \frac{2}{1+x} - x.$$

This system has equilibrium points at  $x = 1$  and  $x = -2$ . We consider the equilibrium point at  $x = 1$  and rewrite the dynamics using  $z = x - 1$ :

$$\frac{dz}{dt} = \frac{2}{2+z} - z - 1,$$

which has an equilibrium point at  $z = 0$ . Now consider the candidate Lyapunov function

$$V(z) = \frac{1}{2}z^2,$$

which is globally positive definite. The derivative of  $V$  along trajectories of the system is given by

$$\dot{V}(z) = z\dot{z} = \frac{2z}{2+z} - z^2 - z.$$

If we restrict our analysis to an interval  $B_r$ , where  $r < 2$ , then  $2 + z > 0$  and we can multiply through by  $2 + z$  to obtain

$$2z - (z^2 + z)(2 + z) = -z^3 - 3z^2 = -z^2(z + 3) < 0, \quad z \in B_r, r < 2.$$

It follows that  $\dot{V}(z) < 0$  for all  $z \in B_r$ ,  $z \neq 0$ , and hence the equilibrium point  $x = 1$  is locally asymptotically stable.  $\nabla$

A slightly more complicated situation occurs if  $\dot{V}$  is negative semidefinite. In this case it is possible that  $\dot{V}(x) = 0$  when  $x \neq 0$ , and hence  $x$  could stop decreasing in value. The following example illustrates this case.

### Example 5.10 Hanging pendulum

A normalized model for a hanging pendulum is

$$\frac{dx_1}{dt} = x_2, \quad \frac{dx_2}{dt} = -\sin x_1,$$

where  $x_1$  is the angle between the pendulum and the vertical, with positive  $x_1$  corresponding to counterclockwise rotation. The equation has an equilibrium  $x_1 = x_2 = 0$ , which corresponds to the pendulum hanging straight down. To explore the stability of this equilibrium we choose the total energy as a Lyapunov function:

$$V(x) = 1 - \cos x_1 + \frac{1}{2}x_2^2 \approx \frac{1}{2}x_1^2 + \frac{1}{2}x_2^2.$$

The Taylor series approximation shows that the function is positive definite for small  $x$ . The time derivative of  $V(x)$  is

$$\dot{V} = \dot{x}_1 \sin x_1 + \dot{x}_2 x_2 = x_2 \sin x_1 - x_2 \sin x_1 = 0.$$

Since this function is negative semidefinite, it follows from Lyapunov's theorem that the equilibrium is stable but not necessarily asymptotically stable. When perturbed, the pendulum actually moves in a trajectory that corresponds to constant energy.  $\nabla$

Lyapunov functions are not always easy to find, and they are not unique. In many cases energy functions can be used as a starting point, as was done in Example 5.10. It turns out that Lyapunov functions can always be found for any stable system (under certain conditions), and hence one knows that if a system is stable, a Lyapunov function exists (and vice versa). Recent results using sum-of-squares methods have provided systematic approaches for finding Lyapunov systems [PPP02]. Sum-of-squares techniques can be applied to a broad variety of systems, including systems whose dynamics are described by polynomial equations, as well as hybrid systems, which can have different models for different regions of state space.

For a linear dynamical system of the form

$$\frac{dx}{dt} = Ax,$$

it is possible to construct Lyapunov functions in a systematic manner. To do so, we consider quadratic functions of the form

$$V(x) = x^T P x,$$

where  $P \in \mathbb{R}^{n \times n}$  is a symmetric matrix ( $P = P^T$ ). The condition that  $V$  be positive definite on  $B_r$  for some  $r > 0$  is equivalent to the condition that  $P$  be a *positive definite matrix*:

$$x^T P x > 0, \quad \text{for all } x \neq 0,$$

which we write as  $P \succ 0$ . It can be shown that if  $P$  is symmetric, then  $P$  is positive definite if and only if all of its eigenvalues are real and positive.

Given a candidate Lyapunov function  $V(x) = x^T P x$ , we can now compute its derivative along flows of the system:

$$\dot{V} = \frac{\partial V}{\partial x} \frac{dx}{dt} = x^T (A^T P + P A) x =: -x^T Q x.$$

The requirement that  $\dot{V}$  be negative definite on  $B_r$  (for asymptotic stability) becomes a condition that the matrix  $Q$  be positive definite. Thus, to find a Lyapunov function for a linear system it is sufficient to choose a  $Q \succ 0$  and solve the *Lyapunov equation*:

$$A^T P + P A = -Q. \tag{5.15}$$

This is a linear equation in the entries of  $P$ , and hence it can be solved using linear algebra. It can be shown that the equation always has a solution if all of



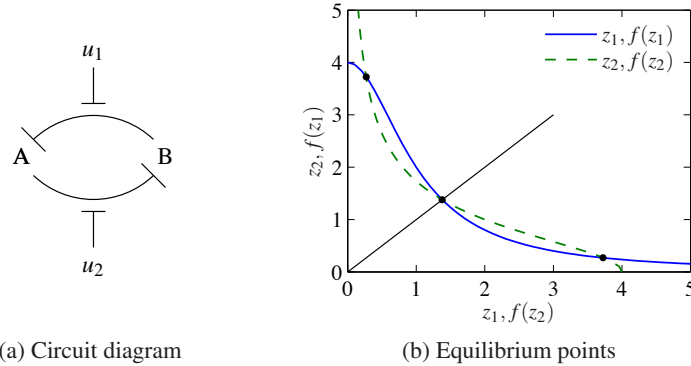

**Figure 5.14:** Stability of a genetic switch. The circuit diagram in (a) represents two proteins that are each repressing the production of the other. The inputs  $u_1$  and  $u_2$  interfere with this repression, allowing the circuit dynamics to be modified. The equilibrium points for this circuit can be determined by the intersection of the two curves shown in (b).

the eigenvalues of the matrix  $A$  are in the left half-plane. Moreover, the solution  $P$  is positive definite if  $Q$  is positive definite. It is thus always possible to find a quadratic Lyapunov function for a stable linear system. We will defer a proof of this until Chapter 6, where more tools for analysis of linear systems will be developed.

Knowing that we have a direct method to find Lyapunov functions for linear systems, we can now investigate the stability of nonlinear systems. Consider the system

$$\frac{dx}{dt} = F(x) =: Ax + \tilde{F}(x), \quad (5.16)$$

where  $F(0) = 0$  and  $\tilde{F}(x)$  contains terms that are second order and higher in the elements of  $x$ . The function  $Ax$  is an approximation of  $F(x)$  near the origin, and we can determine the Lyapunov function for the linear approximation and investigate if it is also a Lyapunov function for the full nonlinear system. The following example illustrates the approach.

### Example 5.11 Genetic switch

Consider the dynamics of a set of repressors connected together in a cycle, as shown in Figure 5.14a. The normalized dynamics for this system were given in Exercise 3.9:

$$\frac{dz_1}{d\tau} = \frac{\mu}{1+z_2^n} - z_1, \quad \frac{dz_2}{d\tau} = \frac{\mu}{1+z_1^n} - z_2, \quad (5.17)$$

where  $z_1$  and  $z_2$  are scaled versions of the protein concentrations,  $n > 0$  and  $\mu > 0$  are parameters that describe the interconnection between the genes and we have set the external inputs  $u_1$  and  $u_2$  to zero.

The equilibrium points for the system are found by equating the time deriva-

tives to zero. We define

$$f(u) = \frac{\mu}{1+u^n}, \quad f'(u) = \frac{df}{du} = \frac{-\mu n u^{n-1}}{(1+u^n)^2},$$

so that our dynamics become

$$\frac{dz_1}{d\tau} = f(z_2) - z_1, \quad \frac{dz_2}{d\tau} = f(z_1) - z_2,$$

and the equilibrium points are defined as the solutions of the equations

$$z_1 = f(z_2), \quad z_2 = f(z_1).$$

If we plot the curves  $(z_1, f(z_1))$  and  $(f(z_2), z_2)$  on a graph, then these equations will have a solution when the curves intersect, as shown in Figure 5.14b. Because of the shape of the curves, it can be shown that there will always be three solutions: one at  $z_{1e} = z_{2e}$ , one with  $z_{1e} < z_{2e}$  and one with  $z_{1e} > z_{2e}$ . If  $\mu \gg 1$ , then we can show that the solutions are given approximately by

$$z_{1e} \approx \mu, \quad z_{2e} \approx \frac{1}{\mu^{n-1}}; \quad z_{1e} = z_{2e}; \quad z_{1e} \approx \frac{1}{\mu^{n-1}}, \quad z_{2e} \approx \mu. \quad (5.18)$$

To check the stability of the system, we write  $f(u)$  in terms of its Taylor series expansion about  $u_e$ :

$$f(u) = f(u_e) + f'(u_e) \cdot (u - u_e) + \frac{1}{2} f''(u_e) \cdot (u - u_e)^2 + \text{higher-order terms},$$

where  $f'$  represents the first derivative of the function, and  $f''$  the second. Using these approximations, the dynamics can then be written as

$$\frac{dw}{dt} = \begin{pmatrix} -1 & f'(z_{2e}) \\ f'(z_{1e}) & -1 \end{pmatrix} w + \tilde{F}(w),$$

where  $w = z - z_e$  is the shifted state and  $\tilde{F}(w)$  represents quadratic and higher-order terms.

We now use equation (5.15) to search for a Lyapunov function. Choosing  $Q = I$  and letting  $P \in \mathbb{R}^{2 \times 2}$  have elements  $p_{ij}$ , we search for a solution of the equation

$$\begin{pmatrix} -1 & f'_1 \\ f'_2 & -1 \end{pmatrix} \begin{pmatrix} p_{11} & p_{12} \\ p_{12} & p_{22} \end{pmatrix} + \begin{pmatrix} p_{11} & p_{12} \\ p_{12} & p_{22} \end{pmatrix} \begin{pmatrix} -1 & f'_2 \\ f'_1 & -1 \end{pmatrix} = \begin{pmatrix} -1 & 0 \\ 0 & -1 \end{pmatrix},$$

where  $f'_1 = f'(z_{1e})$  and  $f'_2 = f'(z_{2e})$ . Note that we have set  $p_{21} = p_{12}$  to force  $P$  to be symmetric. Multiplying out the matrices, we obtain

$$\begin{pmatrix} -2p_{11} + 2f'_1 p_{12} & p_{11} f'_2 - 2p_{12} + p_{22} f'_1 \\ p_{11} f'_2 - 2p_{12} + p_{22} f'_1 & -2p_{22} + 2f'_2 p_{12} \end{pmatrix} = \begin{pmatrix} -1 & 0 \\ 0 & -1 \end{pmatrix},$$

which is a set of *linear* equations for the unknowns  $p_{ij}$ . We can solve these linear equations to obtain

$$p_{11} = -\frac{f_1'^2 - f_2' f_1' + 2}{4(f_1' f_2' - 1)}, \quad p_{12} = -\frac{f_1' + f_2'}{4(f_1' f_2' - 1)}, \quad p_{22} = -\frac{f_2'^2 - f_1' f_2' + 2}{4(f_1' f_2' - 1)}.$$

To check that  $V(w) = w^T P w$  is a Lyapunov function, we must verify that  $V(w)$  is positive definite function or equivalently that  $P \succ 0$ . Since  $P$  is a  $2 \times 2$  symmetric matrix, it has two real eigenvalues  $\lambda_1$  and  $\lambda_2$  that satisfy

$$\lambda_1 + \lambda_2 = \text{trace}(P), \quad \lambda_1 \cdot \lambda_2 = \det(P).$$

In order for  $P$  to be positive definite  $\lambda_1$  and  $\lambda_2$  must be positive, and we thus require that

$$\text{trace}(P) = \frac{f_1'^2 - 2f_2'f_1' + f_2'^2 + 4}{4 - 4f_1'f_2'} > 0, \quad \det(P) = \frac{f_1'^2 - 2f_2'f_1' + f_2'^2 + 4}{16 - 16f_1'f_2'} > 0.$$

We see that  $\text{trace}(P) = 4\det(P)$  and the numerator of the expressions is just  $(f_1 - f_2)^2 + 4 > 0$ , so it suffices to check the sign of  $1 - f_1'f_2'$ . In particular, for  $P$  to be positive definite, we require that

$$f'(z_{1e})f'(z_{2e}) < 1.$$

We can now make use of the expressions for  $f'$  defined earlier and evaluate at the approximate locations of the equilibrium points derived in equation (5.18). For the equilibrium points where  $z_{1e} \neq z_{2e}$ , we can show that

$$f'(z_{1e})f'(z_{2e}) \approx f'(\mu)f'\left(\frac{1}{\mu^{n-1}}\right) = \frac{-\mu n \mu^{n-1}}{(1 + \mu^n)^2} \cdot \frac{-\mu n \mu^{-(n-1)^2}}{(1 + \mu^{-n(n-1)})^2} \approx n^2 \mu^{-n^2+n}.$$

Using  $n = 2$  and  $\mu \approx 200$  from Exercise 3.9, we see that  $f'(z_{1e})f'(z_{2e}) \ll 1$  and hence  $P$  is a positive definite. This implies that  $V$  is a positive definite function and hence a potential Lyapunov function for the system.

To determine if the equilibria  $z_{1e} \neq z_{2e}$  are stable for the system (5.17), we now compute  $\dot{V}$  at the equilibrium point. By construction,

$$\begin{aligned} \dot{V} &= w^T(PA + A^T P)w + \tilde{F}^T(w)Pw + w^T P \tilde{F}(w) \\ &= -w^T w + \tilde{F}^T(w)Pw + w^T P \tilde{F}(w). \end{aligned}$$

Since all terms in  $\tilde{F}$  are quadratic or higher order in  $w$ , it follows that  $\tilde{F}^T(w)Pw$  and  $w^T P \tilde{F}(w)$  consist of terms that are at least third order in  $w$ . Therefore if  $w$  is sufficiently close to zero, then the cubic and higher-order terms will be smaller than the quadratic terms. Hence, sufficiently close to  $w = 0$ ,  $\dot{V}$  is negative definite, allowing us to conclude that these equilibrium points are both stable.

Figure 5.15 shows the phase portrait and time traces for a system with  $\mu = 4$ , illustrating the bistable nature of the system. When the initial condition starts with a concentration of protein B greater than that of A, the solution converges to the equilibrium point at (approximately)  $(1/\mu^{n-1}, \mu)$ . If A is greater than B, then it goes to  $(\mu, 1/\mu^{n-1})$ . The equilibrium point with  $z_{1e} = z_{2e}$  is unstable.  $\nabla$

More generally, we can investigate what the linear approximation tells about the stability of a solution to a nonlinear equation. The following theorem gives a partial answer for the case of stability of an equilibrium point.

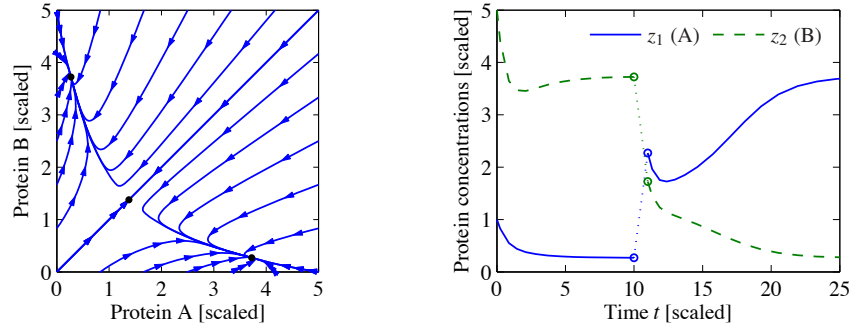

**Figure 5.15:** Dynamics of a genetic switch. The phase portrait on the left shows that the switch has three equilibrium points, corresponding to protein A having a concentration greater than, equal to or less than protein B. The equilibrium point with equal protein concentrations is unstable, but the other equilibrium points are stable. The simulation on the right shows the time response of the system starting from two different initial conditions. The initial portion of the curve corresponds to initial concentrations  $z(0) = (1, 5)$  and converges to the equilibrium where  $z_{1e} < z_{2e}$ . At time  $t = 10$ , the concentrations are perturbed by  $+2$  in  $z_1$  and  $-2$  in  $z_2$ , moving the state into the region of the state space whose solutions converge to the equilibrium point where  $z_{2e} < z_{1e}$ .

**Theorem 5.3.** Consider the dynamical system (5.16) with  $F(0) = 0$  and  $\tilde{F}$  such that  $\lim_{\|x\| \rightarrow 0} \|\tilde{F}(x)\|/\|x\| \rightarrow 0$  as  $\|x\| \rightarrow 0$ . If the real parts of all eigenvalues of  $A$  are strictly less than zero, then  $x_e = 0$  is a locally asymptotically stable equilibrium point of equation (5.16).

This theorem implies that asymptotic stability of the linear approximation implies *local* asymptotic stability of the original nonlinear system. The theorem is very important for control because it implies that stabilization of a linear approximation of a nonlinear system results in a stable equilibrium for the nonlinear system. The proof of this theorem follows the technique used in Example 5.11. A formal proof can be found in [Kha01].

It can also be shown that if  $A$  has one or more eigenvalues with strictly positive real part, then  $x_e = 0$  is an unstable equilibrium for the nonlinear system.



### Krasovski–Lasalle Invariance Principle

For general nonlinear systems, especially those in symbolic form, it can be difficult to find a positive definite function  $V$  whose derivative is strictly negative definite. The Krasovski–Lasalle theorem enables us to conclude the asymptotic stability of an equilibrium point under less restrictive conditions, namely, in the case where  $\dot{V}$  is negative semidefinite, which is often easier to construct. It only applies only to time-invariant or periodic systems, which are the cases we consider here. This section makes use of some additional concepts from dynamical systems; see Hahn [Hah67] or Khalil [Kha01] for a more detailed description.

We will deal with the time-invariant case and begin by introducing a few more

definitions. We denote the solution trajectories of the time-invariant system

$$\frac{dx}{dt} = F(x) \quad (5.19)$$

as  $x(t; a)$ , which is the solution of equation (5.19) at time  $t$  starting from  $a$  at  $t_0 = 0$ . The  $\omega$  limit set of a trajectory  $x(t; a)$  is the set of all points  $z \in \mathbb{R}^n$  such that there exists a strictly increasing sequence of times  $t_n$  such that  $x(t_n; a) \rightarrow z$  as  $n \rightarrow \infty$ . A set  $M \subset \mathbb{R}^n$  is said to be an *invariant set* if for all  $b \in M$ , we have  $x(t; b) \in M$  for all  $t \geq 0$ . It can be proved that the  $\omega$  limit set of every trajectory is closed and invariant. We may now state the Krasovski–Lasalle principle.

**Theorem 5.4** (Krasovski–Lasalle principle). *Let  $V : \mathbb{R}^n \rightarrow \mathbb{R}$  be a locally positive definite function such that on the compact set  $\Omega_r = \{x \in \mathbb{R}^n : V(x) \leq r\}$  we have  $\dot{V}(x) \leq 0$ . Define*

$$S = \{x \in \Omega_r : \dot{V}(x) = 0\}.$$

*As  $t \rightarrow \infty$ , the trajectory tends to the largest invariant set inside  $S$ ; i.e., its  $\omega$  limit set is contained inside the largest invariant set in  $S$ . In particular, if  $S$  contains no invariant sets other than  $x = 0$ , then 0 is asymptotically stable.*

Proofs are given in [Kra63] and [LaS60].

Lyapunov functions can often be used to design stabilizing controllers, as is illustrated by the following example, which also illustrates how the Krasovski–Lasalle principle can be applied.

#### Example 5.12 Inverted pendulum

Following the analysis in Example 3.9, an inverted pendulum can be described by the following normalized model:

$$\frac{dx_1}{dt} = x_2, \quad \frac{dx_2}{dt} = \sin x_1 + u \cos x_1, \quad (5.20)$$

where  $x_1$  is the angular deviation from the upright position and  $u$  is the (scaled) acceleration of the pivot, as shown in Figure 5.16a. The system has an equilibrium at  $x_1 = x_2 = 0$ , which corresponds to the pendulum standing upright. This equilibrium is unstable.

To find a stabilizing controller we consider the following candidate for a Lyapunov function:

$$V(x) = (\cos x_1 - 1) + a(1 - \cos^2 x_1) + \frac{1}{2}x_2^2 \approx \left(a - \frac{1}{2}\right)x_1^2 + \frac{1}{2}x_2^2.$$

The Taylor series expansion shows that the function is positive definite near the origin if  $a > 0.5$ . The time derivative of  $V(x)$  is

$$\dot{V} = -\dot{x}_1 \sin x_1 + 2a\dot{x}_1 \sin x_1 \cos x_1 + \dot{x}_2 x_2 = x_2(u + 2a \sin x_1) \cos x_1.$$

Choosing the feedback law

$$u = -2a \sin x_1 - x_2 \cos x_1$$

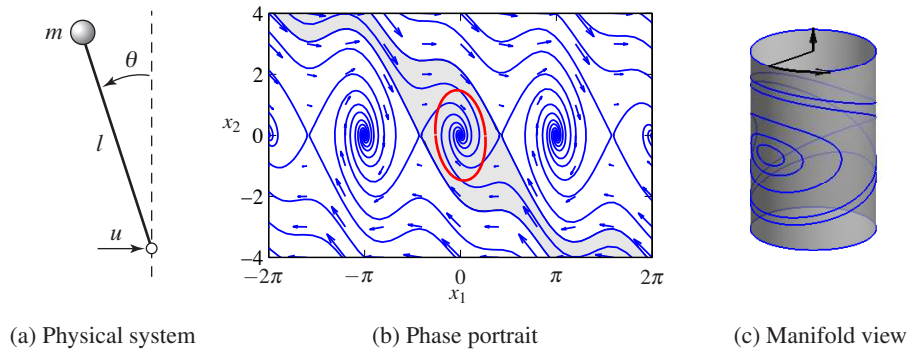

**Figure 5.16:** Stabilized inverted pendulum. A control law applies a force  $u$  at the bottom of the pendulum to stabilize the inverted position (a). The phase portrait (b) shows that the equilibrium point corresponding to the vertical position is stabilized. The shaded region indicates the set of initial conditions that converge to the origin. The ellipse corresponds to a level set of a Lyapunov function  $V(x)$  for which  $V(x) > 0$  and  $\dot{V}(x) < 0$  for all points inside the ellipse. This can be used as an estimate of the region of attraction of the equilibrium point. The actual dynamics of the system evolve on a manifold (c).

gives

$$\dot{V} = -x_2^2 \cos^2 x_1.$$

It follows from Lyapunov's theorem that the equilibrium is (locally) stable. However, since the function is only negative semidefinite, we cannot conclude asymptotic stability using Theorem 5.2. However, note that  $\dot{V} = 0$  implies that  $x_2 = 0$  or  $x_1 = \pi/2 \pm n\pi$ .

If we restrict our analysis to a small neighborhood of the origin  $\Omega_r$ ,  $r \ll \pi/2$ , then we can define

$$S = \{(x_1, x_2) \in \Omega_r : x_2 = 0\}$$

and we can compute the largest invariant set inside  $S$ . For a trajectory to remain in this set we must have  $x_2 = 0$  for all  $t$  and hence  $\dot{x}_2(t) = 0$  as well. Using the dynamics of the system (5.20), we see that  $x_2(t) = 0$  and  $\dot{x}_2(t) = 0$  implies  $x_1(t) = 0$  as well. Hence the largest invariant set inside  $S$  is  $(x_1, x_2) = 0$ , and we can use the Krasovski–Lasalle principle to conclude that the origin is locally asymptotically stable. A phase portrait of the closed loop system is shown in Figure 5.16b.

In the analysis and the phase portrait, we have treated the angle of the pendulum  $\theta = x_1$  as a real number. In fact,  $\theta$  is an angle with  $\theta = 2\pi$  equivalent to  $\theta = 0$ . Hence the dynamics of the system actually evolves on a *manifold* (smooth surface) as shown in Figure 5.16c. Analysis of nonlinear dynamical systems on manifolds is more complicated, but uses many of the same basic ideas presented here.  $\nabla$



## 5.5 Parametric and Nonlocal Behavior

Most of the tools that we have explored are focused on the local behavior of a fixed system near an equilibrium point. In this section we briefly introduce some concepts regarding the global behavior of nonlinear systems and the dependence of a system's behavior on parameters in the system model.

### Regions of Attraction

To get some insight into the behavior of a nonlinear system we can start by finding the equilibrium points. We can then proceed to analyze the local behavior around the equilibria. The behavior of a system near an equilibrium point is called the *local* behavior of the system.

The solutions of the system can be very different far away from an equilibrium point. This is seen, for example, in the stabilized pendulum in Example 5.12. The inverted equilibrium point is stable, with small oscillations that eventually converge to the origin. But far away from this equilibrium point there are trajectories that converge to other equilibrium points or even cases in which the pendulum swings around the top multiple times, giving very long oscillations that are topologically different from those near the origin.

To better understand the dynamics of the system, we can examine the set of all initial conditions that converge to a given asymptotically stable equilibrium point. This set is called the *region of attraction* for the equilibrium point. An example is shown by the shaded region of the phase portrait in Figure 5.16b. In general, computing regions of attraction is difficult. However, even if we cannot determine the region of attraction, we can often obtain patches around the stable equilibria that are attracting. This gives partial information about the behavior of the system.

One method for approximating the region of attraction is through the use of Lyapunov functions. Suppose that  $V$  is a local Lyapunov function for a system around an equilibrium point  $x_0$ . Let  $\Omega_r$  be a set on which  $V(x)$  has a value less than  $r$ ,

$$\Omega_r = \{x \in \mathbb{R}^n : V(x) \leq r\},$$

and suppose that  $\dot{V}(x) \leq 0$  for all  $x \in \Omega_r$ , with equality only at the equilibrium point  $x_0$ . Then  $\Omega_r$  is inside the region of attraction of the equilibrium point. Since this approximation depends on the Lyapunov function and the choice of Lyapunov function is not unique, it can sometimes be a very conservative estimate.

It is sometimes the case that we can find a Lyapunov function  $V$  such that  $V$  is positive definite and  $\dot{V}$  is negative (semi-) definite for all  $x \in \mathbb{R}^n$ . In many instances it can then be shown that the region of attraction for the equilibrium point is the entire state space, and the equilibrium point is *globally* asymptotically stable. More detailed conditions for global stability can be found in [Kha01].

### Example 5.13 Stabilized inverted pendulum

Consider again the stabilized inverted pendulum from Example 5.12. The Lya-

punov function for the system was

$$V(x) = (\cos x_1 - 1) + a(1 - \cos^2 x_1) + \frac{1}{2}x_2^2.$$

With  $a > 0.5$ ,  $\dot{V}$  was negative semidefinite for all  $x$  and nonzero when  $x_1 \neq \pm\pi/2$ . Hence any  $x$  such that  $|x_1| < \pi/2$  and  $V(x) > 0$  will be inside the invariant set defined by the level curves of  $V(x)$ . One of these level sets is shown in Figure 5.16b.

▽

### Bifurcations

Another important property of nonlinear systems is how their behavior changes as the parameters governing the dynamics change. We can study this in the context of models by exploring how the location of equilibrium points, their stability, their regions of attraction and other dynamic phenomena, such as limit cycles, vary based on the values of the parameters in the model.

Consider a differential equation of the form

$$\frac{dx}{dt} = F(x, \mu), \quad x \in \mathbb{R}^n, \mu \in \mathbb{R}^k, \quad (5.21)$$

where  $x$  is the state and  $\mu$  is a set of parameters that describe the family of equations. The equilibrium solutions satisfy

$$F(x, \mu) = 0,$$

and as  $\mu$  is varied, the corresponding solutions  $x_e(\mu)$  can also vary. We say that the system (5.21) has a *bifurcation* at  $\mu = \mu^*$  if the behavior of the system changes qualitatively at  $\mu^*$ . This can occur either because of a change in stability type or a change in the number of solutions at a given value of  $\mu$ .

#### Example 5.14 Predator–prey

Consider the predator–prey system described in Example 3.3 and modeled as a continuous time system as described in Section 4.7. The dynamics of the system are given by

$$\frac{dH}{dt} = rH \left(1 - \frac{H}{k}\right) - \frac{aHL}{c+H}, \quad \frac{dL}{dt} = b \frac{aHL}{c+H} - dL, \quad (5.22)$$

where  $H$  and  $L$  are the numbers of hares (prey) and lynxes (predators) and  $a$ ,  $b$ ,  $c$ ,  $d$ ,  $k$  and  $r$  are parameters that model a given predator–prey system (described in more detail in Section 4.7). The system has an equilibrium point at  $H_e > 0$  and  $L_e > 0$  that can be found numerically.

To explore how the parameters of the model affect the behavior of the system, we choose to focus on two specific parameters of interest:  $a$ , the interaction coefficient between the populations and  $c$ , a parameter affecting the prey consumption rate. Figure 5.17a is a numerically computed *parametric stability diagram* showing the regions in the chosen parameter space for which the equilibrium point is



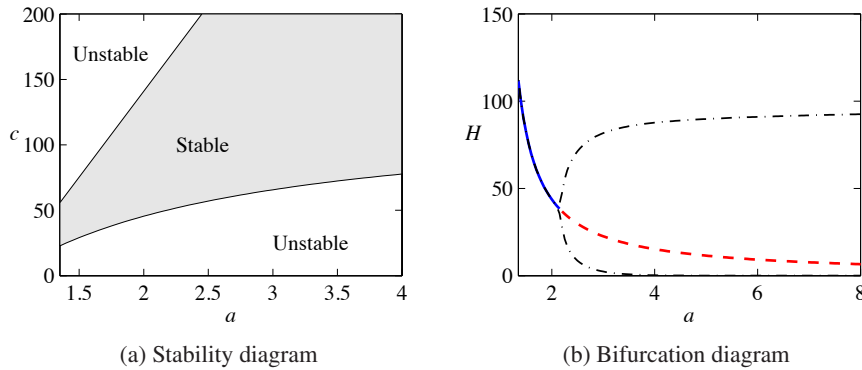

**Figure 5.17:** Bifurcation analysis of the predator–prey system. (a) Parametric stability diagram showing the regions in parameter space for which the system is stable. (b) Bifurcation diagram showing the location and stability of the equilibrium point as a function of  $a$ . The solid line represents a stable equilibrium point, and the dashed line represents an unstable equilibrium point. The dashed-dotted lines indicate the upper and lower bounds for the limit cycle at that parameter value (computed via simulation). The nominal values of the parameters in the model are  $a = 3.2$ ,  $b = 0.6$ ,  $c = 50$ ,  $d = 0.56$ ,  $k = 125$  and  $r = 1.6$ .

stable (leaving the other parameters at their nominal values). We see from this figure that for certain combinations of  $a$  and  $c$  we get a stable equilibrium point, while at other values this equilibrium point is unstable.

Figure 5.17b is a numerically computed *bifurcation diagram* for the system. In this plot, we choose one parameter to vary ( $a$ ) and then plot the equilibrium value of one of the states ( $H$ ) on the vertical axis. The remaining parameters are set to their nominal values. A solid line indicates that the equilibrium point is stable; a dashed line indicates that the equilibrium point is unstable. Note that the stability in the bifurcation diagram matches that in the parametric stability diagram for  $c = 50$  (the nominal value) and  $a$  varying from 1.35 to 4. For the predator–prey system, when the equilibrium point is unstable, the solution converges to a stable limit cycle. The amplitude of this limit cycle is shown by the dashed-dotted line in Figure 5.17b.  $\nabla$

A particular form of bifurcation that is very common when controlling linear systems is that the equilibrium remains fixed but the stability of the equilibrium changes as the parameters are varied. In such a case it is revealing to plot the eigenvalues of the system as a function of the parameters. Such plots are called *root locus diagrams* because they give the locus of the eigenvalues when parameters change. Bifurcations occur when parameter values are such that there are eigenvalues with zero real part. Computing environments such LabVIEW, MATLAB and Mathematica have tools for plotting root loci. A more detailed discussion of the root locus is given in Section 12.5.

#### Example 5.15 Root locus diagram for a bicycle model

Consider the linear bicycle model given by equation (4.7) in Section 4.2. Introduc-

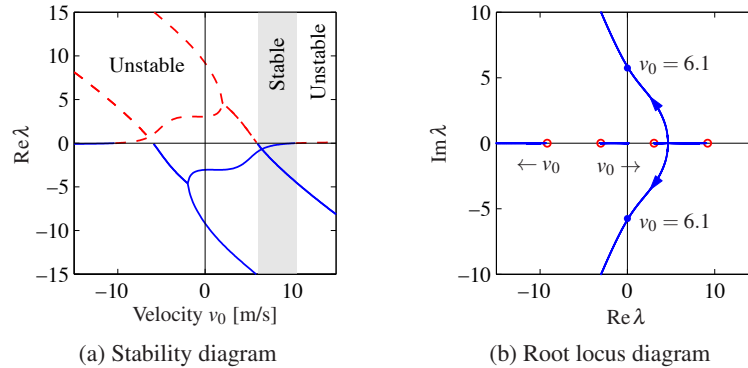

**Figure 5.18:** Stability plots for a bicycle moving at constant velocity. The plot in (a) shows the real part of the system eigenvalues as a function of the bicycle velocity  $v_0$ . The system is stable when all eigenvalues have negative real part (shaded region). The plot in (b) shows the locus of eigenvalues on the complex plane as the velocity  $v$  is varied and gives a different view of the stability of the system. This type of plot is called a *root locus diagram*.

ing the state variables  $x_1 = \phi$ ,  $x_2 = \delta$ ,  $x_3 = \dot{\phi}$  and  $x_4 = \dot{\delta}$  and setting the steering torque  $T = 0$ , the equations can be written as

$$\frac{dx}{dt} = \begin{pmatrix} 0 & I \\ -M^{-1}(K_0 + K_2 v_0^2) & -M^{-1}C v_0 \end{pmatrix} x =: Ax,$$

where  $I$  is a  $2 \times 2$  identity matrix and  $v_0$  is the velocity of the bicycle. Figure 5.18a shows the real parts of the eigenvalues as a function of velocity. Figure 5.18b shows the dependence of the eigenvalues of  $A$  on the velocity  $v_0$ . The figures show that the bicycle is unstable for low velocities because two eigenvalues are in the right half-plane. As the velocity increases, these eigenvalues move into the left half-plane, indicating that the bicycle becomes self-stabilizing. As the velocity is increased further, there is an eigenvalue close to the origin that moves into the right half-plane, making the bicycle unstable again. However, this eigenvalue is small and so it can easily be stabilized by a rider. Figure 5.18a shows that the bicycle is self-stabilizing for velocities between 6 and 10 m/s.  $\nabla$

Parametric stability diagrams and bifurcation diagrams can provide valuable insights into the dynamics of a nonlinear system. It is usually necessary to carefully choose the parameters that one plots, including combining the natural parameters of the system to eliminate extra parameters when possible. Computer programs such as AUTO, LOCBIF and XPPAUT provide numerical algorithms for producing stability and bifurcation diagrams.

### Design of Nonlinear Dynamics Using Feedback

In most of the text we will rely on linear approximations to design feedback laws that stabilize an equilibrium point and provide a desired level of performance. However, for some classes of problems the feedback controller must be nonlinear

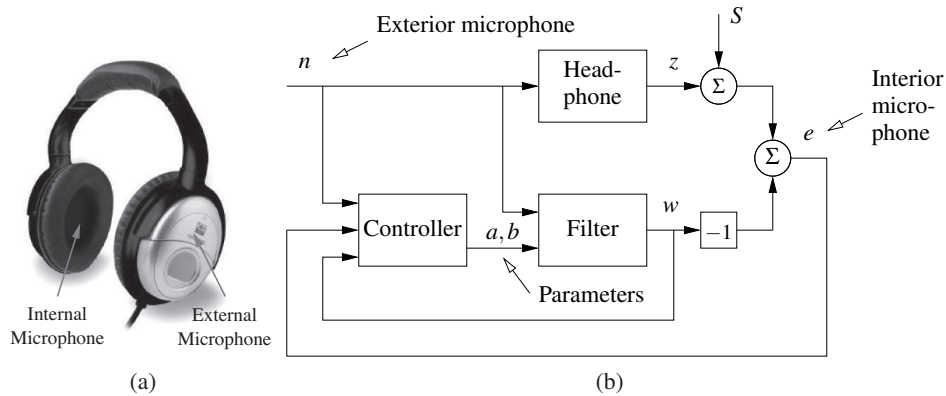

**Figure 5.19:** Headphones with noise cancellation. Noise is sensed by the exterior microphone (a) and sent to a filter in such a way that it cancels the noise that penetrates the headphone (b). The filter parameters  $a$  and  $b$  are adjusted by the controller.  $S$  represents the input signal to the headphones.

to accomplish its function. By making use of Lyapunov functions we can often design a nonlinear control law that provides stable behavior, as we saw in Example 5.12.

One way to systematically design a nonlinear controller is to begin with a candidate Lyapunov function  $V(x)$  and a control system  $\dot{x} = f(x, u)$ . We say that  $V(x)$  is a *control Lyapunov function* if for every  $x$  there exists a  $u$  such that  $\dot{V}(x) = \frac{\partial V}{\partial x} f(x, u) < 0$ . In this case, it may be possible to find a function  $\alpha(x)$  such that  $u = \alpha(x)$  stabilizes the system. The following example illustrates the approach.

#### Example 5.16 Noise cancellation

Noise cancellation is used in consumer electronics and in industrial systems to reduce the effects of noise and vibrations. The idea is to locally reduce the effect of noise by generating opposing signals. A pair of headphones with noise cancellation such as those shown in Figure 5.19a is a typical example. A schematic diagram of the system is shown in Figure 5.19b. The system has two microphones, one outside the headphones that picks up exterior noise  $n$  and another inside the headphones that picks up the signal  $e$ , which is a combination of the desired signal  $S$  and the external noise that penetrates the headphone. The signal from the exterior microphone is filtered and sent to the headphones in such a way that it cancels the external noise that penetrates into the headphones. The parameters of the filter are adjusted by a feedback mechanism to make the noise signal in the internal microphone as small as possible. The feedback is inherently nonlinear because it acts by changing the parameters of the filter.

To analyze the system we assume for simplicity that the propagation of external noise into the headphones is modeled by a first-order dynamical system described by

$$\frac{dz}{dt} = a_0 z + b_0 n, \quad (5.23)$$

where  $z$  is the sound level and the parameters  $a_0 < 0$  and  $b_0$  are not known. Assume that the filter is a dynamical system of the same type:

$$\frac{dw}{dt} = aw + bn,$$

where the parameters  $a$  and  $b$  are adjustable. We wish to find a controller that updates  $a$  and  $b$  so that they converge to the (unknown) parameters  $a_0$  and  $b_0$ . If  $a = a_0$  and  $b = b_0$  we have  $e = S$  and the noise effect of the noise is eliminated. Assuming for simplicity that  $S = 0$ , introduce  $x_1 = e = w - z$ ,  $x_2 = a - a_0$  and  $x_3 = b - b_0$ ; then

$$\frac{dx_1}{dt} = a_0(w - z) + (a - a_0)w + (b - b_0)n = a_0x_1 + x_2w + x_3n. \quad (5.24)$$

We will achieve noise cancellation if we can find a feedback law for changing the parameters  $a$  and  $b$  so that the error  $e$  goes to zero. To do this we choose

$$V(x_1, x_2, x_3) = \frac{1}{2}(\alpha x_1^2 + x_2^2 + x_3^2)$$

as a candidate Lyapunov function for (5.24). The derivative of  $V$  is

$$\dot{V} = \alpha x_1 \dot{x}_1 + x_2 \dot{x}_2 + x_3 \dot{x}_3 = \alpha a_0 x_1^2 + x_2(\dot{x}_2 + \alpha w x_1) + x_3(\dot{x}_3 + \alpha n x_1).$$

Choosing

$$\dot{a} = \dot{x}_2 = -\alpha w x_1 = -\alpha w e, \quad \dot{b} = \dot{x}_3 = -\alpha n x_1 = -\alpha n e, \quad (5.25)$$

we find that  $\dot{V} = \alpha a_0 x_1^2 < 0$ , and it follows that the quadratic function will decrease as long as  $e = x_1 = w - z \neq 0$ . The nonlinear feedback (5.25) thus attempts to change the parameters so that the error between the signal and the noise is small. Notice that feedback law (5.25) does not use the model (5.23) explicitly.

A simulation of the system is shown in Figure 5.20. In the simulation we have represented the signal as a pure sinusoid and the noise as broad band noise. The figure shows the dramatic improvement with noise cancellation. The sinusoidal signal is not visible without noise cancellation. The filter parameters change quickly from their initial values  $a = b = 0$ . Filters of higher order with more coefficients are used in practice.  $\nabla$

## 5.6 Further Reading

The field of dynamical systems has a rich literature that characterizes the possible features of dynamical systems and describes how parametric changes in the dynamics can lead to topological changes in behavior. Readable introductions to dynamical systems are given by Strogatz [Str94] and the highly illustrated text by Abraham and Shaw [AS82]. More technical treatments include Andronov, Vitt and Khaikin [AVK87], Guckenheimer and Holmes [GH83] and Wiggins [Wig90]. For students with a strong interest in mechanics, the texts by Arnold [Arn87] and

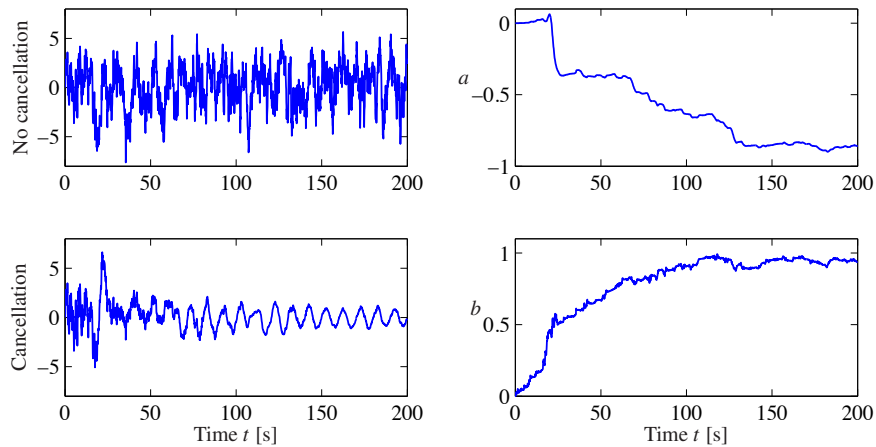

**Figure 5.20:** Simulation of noise cancellation. The top left figure shows the headphone signal without noise cancellation, and the bottom left figure shows the signal with noise cancellation. The right figures show the parameters  $a$  and  $b$  of the filter.

Marsden and Ratiu [MR94] provide an elegant approach using tools from differential geometry. Finally, good treatments of dynamical systems methods in biology are given by Wilson [Wil99] and Ellner and Guckenheimer [EG05]. There is a large literature on Lyapunov stability theory, including the classic texts by Malkin [Mal59], Hahn [Hah67] and Krasovski [Kra63]. We highly recommend the comprehensive treatment by Khalil [Kha01].

## Exercises

**5.1** (Time-invariant systems) Show that if we have a solution of the differential equation (5.1) given by  $x(t)$  with initial condition  $x(t_0) = x_0$ , then  $\tilde{x}(\tau) = x(t - t_0)$  is a solution of the differential equation

$$\frac{d\tilde{x}}{d\tau} = F(\tilde{x})$$

with initial condition  $\tilde{x}(0) = x_0$ , where  $\tau = t - t_0$ .

**5.2** (Flow in a tank) A cylindrical tank has cross section  $A \text{ m}^2$ , effective outlet area  $a \text{ m}^2$  and inflow  $q_{in} \text{ m}^3/\text{s}$ . An energy balance shows that the outlet velocity is  $v = \sqrt{2gh} \text{ m/s}$ , where  $g \text{ m/s}^2$  is the acceleration of gravity and  $h$  is the distance between the outlet and the water level in the tank (in meters). Show that the system can be modeled by

$$\frac{dh}{dt} = -\frac{a}{A}\sqrt{2gh} + \frac{1}{A}q_{in}, \quad q_{out} = a\sqrt{2gh}.$$

Use the parameters  $A = 0.2$ ,  $a = 0.01$ . Simulate the system when the inflow is zero and the initial level is  $h = 0.2$ . Do you expect any difficulties in the simulation?

**5.3 (Cruise control)** Consider the cruise control system described in Section 4.1. Generate a phase portrait for the closed loop system on flat ground ( $\theta = 0$ ), in third gear, using a PI controller (with  $k_p = 0.5$  and  $k_i = 0.1$ ),  $m = 1000$  kg and desired speed 20 m/s. Your system model should include the effects of saturating the input between 0 and 1.

**5.4 (Lyapunov functions)** Consider the second-order system

$$\frac{dx_1}{dt} = -ax_1, \quad \frac{dx_2}{dt} = -bx_1 - cx_2,$$

where  $a, b, c > 0$ . Investigate whether the functions

$$V_1(x) = \frac{1}{2}x_1^2 + \frac{1}{2}x_2^2, \quad V_2(x) = \frac{1}{2}x_1^2 + \frac{1}{2}\left(x_2 + \frac{b}{c-a}x_1\right)^2$$

are Lyapunov functions for the system and give any conditions that must hold.



**5.5 (Damped spring–mass system)** Consider a damped spring–mass system with dynamics

$$m\ddot{q} + c\dot{q} + kq = 0.$$

A natural candidate for a Lyapunov function is the total energy of the system, given by

$$V = \frac{1}{2}m\dot{q}^2 + \frac{1}{2}kq^2.$$

Use the Krasovski–Lasalle theorem to show that the system is asymptotically stable.

**5.6 (Electric generator)** The following simple model for an electric generator connected to a strong power grid was given in Exercise 3.7:

$$J\frac{d^2\varphi}{dt^2} = P_m - P_e = P_m - \frac{EV}{X}\sin\varphi.$$

The parameter

$$a = \frac{P_{\max}}{P_m} = \frac{EV}{XP_m} \quad (5.26)$$

is the ratio between the maximum deliverable power  $P_{\max} = EV/X$  and the mechanical power  $P_m$ .

(a) Consider  $a$  as a bifurcation parameter and discuss how the equilibria depend on  $a$ .

(b) For  $a > 1$ , show that there is a center at  $\varphi_0 = \arcsin(1/a)$  and a saddle at  $\varphi = \pi - \varphi_0$ .

(c) Show that if  $P_m/J = 1$  there is a solution through the saddle that satisfies

$$\frac{1}{2}\left(\frac{d\varphi}{dt}\right)^2 - \varphi + \varphi_0 - a\cos\varphi - \sqrt{a^2 - 1} = 0. \quad (5.27)$$

Use simulation to show that the stability region is the interior of the area enclosed by this solution. Investigate what happens if the system is in equilibrium with a

value of  $a$  that is slightly larger than 1 and  $a$  suddenly decreases, corresponding to the reactance of the line suddenly increasing.

**5.7** (Lyapunov equation) Show that Lyapunov equation (5.15) always has a solution if all of the eigenvalues of  $A$  are in the left half-plane. (Hint: Use the fact that the Lyapunov equation is linear in  $P$  and start with the case where  $A$  has distinct eigenvalues.)

**5.8** (Congestion control) Consider the congestion control problem described in Section 4.4. Confirm that the equilibrium point for the system is given by equation (4.21) and compute the stability of this equilibrium point using a linear approximation.

**5.9** (Swinging up a pendulum) Consider the inverted pendulum, discussed in Example 5.4, that is described by

$$\ddot{\theta} = \sin \theta + u \cos \theta,$$

where  $\theta$  is the angle between the pendulum and the vertical and the control signal  $u$  is the acceleration of the pivot. Using the energy function

$$V(\theta, \dot{\theta}) = \cos \theta - 1 + \frac{1}{2} \dot{\theta}^2,$$

show that the state feedback  $u = k(V_0 - V)\dot{\theta} \cos \theta$  causes the pendulum to “swing up” to the upright position.

**5.10** (Root locus diagram) Consider the linear system

$$\frac{dx}{dt} = \begin{pmatrix} 0 & 1 \\ 0 & -3 \end{pmatrix} x + \begin{pmatrix} -1 \\ 4 \end{pmatrix} u, \quad y = \begin{pmatrix} 1 & 0 \end{pmatrix} x,$$

with the feedback  $u = -ky$ . Plot the location of the eigenvalues as a function the parameter  $k$ .

**5.11** (Discrete-time Lyapunov function) Consider a nonlinear discrete-time system with dynamics  $x[k+1] = f(x[k])$  and equilibrium point  $x_e = 0$ . Suppose there exists a smooth, positive definite function  $V: \mathbb{R}^n \rightarrow \mathbb{R}$  such that  $V(f(x)) - V(x) < 0$  for  $x \neq 0$  and  $V(0) = 0$ . Show that  $x_e = 0$  is (locally) asymptotically stable. 

**5.12** (Operational amplifier oscillator) An op amp circuit for an oscillator was shown in Exercise 4.5. The oscillatory solution for that linear circuit was stable but not asymptotically stable. A schematic of a modified circuit that has nonlinear elements is shown in the figure below. The modification is obtained by making a feedback around each operational amplifier that has capacitors using multipliers. The signal  $a_e = v_1^2 + v_2^2/\alpha^2 - v_0^2$  is the amplitude error. Show that the system is modeled by

$$\begin{aligned} \frac{dv_1}{dt} &= \frac{R_4}{R_1 R_3 C_1} v_2 + \frac{1}{R_{11} C_1} v_1 (v_0^2 - v_1^2 - \frac{v_2^2}{\alpha^2}), \\ \frac{dv_2}{dt} &= -\frac{1}{R_2 C_2} v_1 + \frac{1}{R_{22} C_2} v_2 (v_0^2 - v_1^2 - \frac{v_2^2}{\alpha^2}). \end{aligned}$$

Determine  $\alpha$  so that the the circuit gives an oscillation with a stable limit cycle with amplitude  $v_0$ . (Hint: Use the results of Example 5.8.)

**5.13** (Self-activating genetic circuit) Consider the dynamics of a genetic circuit that implements *self-activation*: the protein produced by the gene is an activator for the protein, thus stimulating its own production through positive feedback. Using the models presented in Example 3.15, the dynamics for the system can be written as

$$\frac{dm}{dt} = \frac{\alpha p^2}{1 + kp^2} + \alpha_0 - \gamma m, \quad \frac{dp}{dt} = \beta m - \delta p, \quad (5.28)$$

for  $p, m \geq 0$ . Find the equilibrium points for the system and analyze the local stability of each using Lyapunov analysis.

**5.14** (Diagonal systems) Let  $A \in \mathbb{R}^{n \times n}$  be a square matrix with real eigenvalues  $\lambda_1, \dots, \lambda_n$  and corresponding eigenvectors  $v_1, \dots, v_n$ .

(a) Show that if the eigenvalues are distinct ( $\lambda_i \neq \lambda_j$  for  $i \neq j$ ), then  $v_i \neq v_j$  for  $i \neq j$ .

(b) Show that the eigenvectors form a basis for  $\mathbb{R}^n$  so that any vector  $x$  can be written as  $x = \sum \alpha_i v_i$  for  $\alpha_i \in \mathbb{R}$ .

(c) Let  $T = \begin{pmatrix} v_1 & v_2 & \dots & v_n \end{pmatrix}$  and show that  $T^{-1}AT$  is a diagonal matrix of the form (5.8).

(d) Show that if some of the  $\lambda_i$  are complex numbers, then  $A$  can be written as

$$A = \begin{pmatrix} \Lambda_1 & & 0 \\ & \ddots & \\ 0 & & \Lambda_k \end{pmatrix} \quad \text{where} \quad \Lambda_i = \lambda \in \mathbb{R} \quad \text{or} \quad \Lambda_i = \begin{pmatrix} \sigma & \omega \\ -\omega & \sigma \end{pmatrix}.$$

in an appropriate set of coordinates.

This form of the dynamics of a linear system is often referred to as *block diagonal form*.

**5.15** (Furuta pendulum) The Furuta pendulum, an inverted pendulum on a rotating arm, is shown to the left in the figure below.

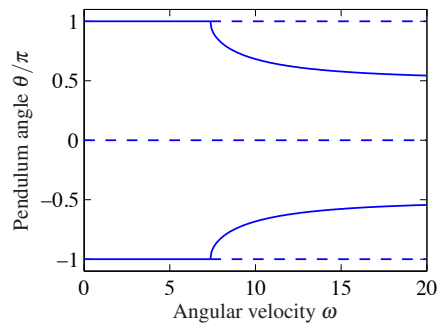
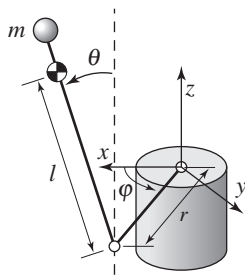



Consider the situation when the pendulum arm is spinning with constant rate. The system has multiple equilibrium points that depend on the angular velocity  $\omega$ , as shown in the bifurcation diagram on the right.

The equations of motion for the system are given by

$$J_p \ddot{\theta} - J_p \omega_0^2 \sin \theta \cos \theta - m_p g l \sin \theta = 0,$$

where  $J_p$  is the moment of inertia of the pendulum with respect to its pivot,  $m_p$  is the pendulum mass,  $l$  is the distance between the pivot and the center of mass of the pendulum and  $\omega_0$  is the the rate of rotation of the arm.

- (a) Determine the equilibria for the system and the condition(s) for stability of each equilibrium point (in terms of  $\omega_0$ ).
- (b) Consider the angular velocity as a bifurcation parameter and verify the bifurcation diagram given above. This is an example of a *pitchfork bifurcation*.

**5.16** (Routh-Hurwitz criterion) Consider a linear differential equation with the characteristic polynomial

$$\lambda(s) = s^2 + a_1 s + a_2, \quad \lambda(s) = s^3 + a_1 s^2 + a_2 s + a_3.$$

Show that the system is asymptotically stable if and only if all the coefficients  $a_i$  are positive and if  $a_1 a_2 > a_3$ . This is a special case of a more general set of criteria known as the Routh-Hurwitz criterion.



---

## Chapter Six

### Linear Systems

*Few physical elements display truly linear characteristics. For example the relation between force on a spring and displacement of the spring is always nonlinear to some degree. The relation between current through a resistor and voltage drop across it also deviates from a straight-line relation. However, if in each case the relation is reasonably linear, then it will be found that the system behavior will be very close to that obtained by assuming an ideal, linear physical element, and the analytical simplification is so enormous that we make linear assumptions wherever we can possibly do so in good conscience.*

Robert H. Cannon, *Dynamics of Physical Systems*, 1967 [Can03].

In Chapters 3–5 we considered the construction and analysis of differential equation models for dynamical systems. In this chapter we specialize our results to the case of linear, time-invariant input/output systems. Two central concepts are the matrix exponential and the convolution equation, through which we can completely characterize the behavior of a linear system. We also describe some properties of the input/output response and show how to approximate a nonlinear system by a linear one.

#### 6.1 Basic Definitions

We have seen several instances of linear differential equations in the examples in the previous chapters, including the spring–mass system (damped oscillator) and the operational amplifier in the presence of small (nonsaturating) input signals. More generally, many dynamical systems can be modeled accurately by linear differential equations. Electrical circuits are one example of a broad class of systems for which linear models can be used effectively. Linear models are also broadly applicable in mechanical engineering, for example, as models of small deviations from equilibria in solid and fluid mechanics. Signal-processing systems, including digital filters of the sort used in CD and MP3 players, are another source of good examples, although these are often best modeled in discrete time (as described in more detail in the exercises).

In many cases, we *create* systems with a linear input/output response through the use of feedback. Indeed, it was the desire for linear behavior that led Harold S. Black to the invention of the negative feedback amplifier. Almost all modern signal processing systems, whether analog or digital, use feedback to produce linear or near-linear input/output characteristics. For these systems, it is often useful to represent the input/output characteristics as linear, ignoring the internal details required to get that linear response.

For other systems, nonlinearities cannot be ignored, especially if one cares about the global behavior of the system. The predator–prey problem is one example of this: to capture the oscillatory behavior of the interdependent populations we must include the nonlinear coupling terms. Other examples include switching behavior and generating periodic motion for locomotion. However, if we care about what happens near an equilibrium point, it often suffices to approximate the nonlinear dynamics by their local linearization, as we already explored briefly in Section 5.3. The linearization is essentially an approximation of the nonlinear dynamics around the desired operating point.

### Linearity

We now proceed to define linearity of input/output systems more formally. Consider a state space system of the form

$$\frac{dx}{dt} = f(x, u), \quad y = h(x, u), \quad (6.1)$$

where  $x \in \mathbb{R}^n$ ,  $u \in \mathbb{R}^p$  and  $y \in \mathbb{R}^q$ . As in the previous chapters, we will usually restrict ourselves to the single-input, single-output case by taking  $p = q = 1$ . We also assume that all functions are smooth and that for a reasonable class of inputs (e.g., piecewise continuous functions of time) the solutions of equation (6.1) exist for all time.

It will be convenient to assume that the origin  $x = 0$ ,  $u = 0$  is an equilibrium point for this system ( $\dot{x} = 0$ ) and that  $h(0, 0) = 0$ . Indeed, we can do so without loss of generality. To see this, suppose that  $(x_e, u_e) \neq (0, 0)$  is an equilibrium point of the system with output  $y_e = h(x_e, u_e)$ . Then we can define a new set of states, inputs and outputs,

$$\tilde{x} = x - x_e, \quad \tilde{u} = u - u_e, \quad \tilde{y} = y - y_e,$$

and rewrite the equations of motion in terms of these variables:

$$\begin{aligned} \frac{d}{dt} \tilde{x} &= f(\tilde{x} + x_e, \tilde{u} + u_e) =: \tilde{f}(\tilde{x}, \tilde{u}), \\ \tilde{y} &= h(\tilde{x} + x_e, \tilde{u} + u_e) - y_e =: \tilde{h}(\tilde{x}, \tilde{u}). \end{aligned}$$

In the new set of variables, the origin is an equilibrium point with output 0, and hence we can carry out our analysis in this set of variables. Once we have obtained our answers in this new set of variables, we simply “translate” them back to the original coordinates using  $x = \tilde{x} + x_e$ ,  $u = \tilde{u} + u_e$  and  $y = \tilde{y} + y_e$ .

Returning to the original equations (6.1), now assuming without loss of generality that the origin is the equilibrium point of interest, we write the output  $y(t)$  corresponding to the initial condition  $x(0) = x_0$  and input  $u(t)$  as  $y(t; x_0, u)$ . Using this notation, a system is said to be a *linear input/output system* if the following

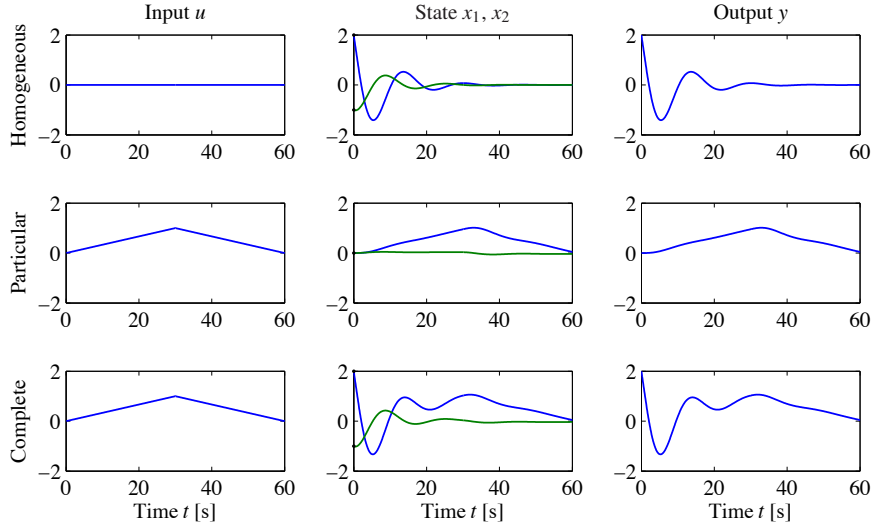

**Figure 6.1:** Superposition of homogeneous and particular solutions. The first row shows the input, state and output corresponding to the initial condition response. The second row shows the same variables corresponding to zero initial condition but nonzero input. The third row is the complete solution, which is the sum of the two individual solutions.

conditions are satisfied:

$$\begin{aligned}
 \text{(i)} \quad & y(t; \alpha x_1 + \beta x_2, 0) = \alpha y(t; x_1, 0) + \beta y(t; x_2, 0), \\
 \text{(ii)} \quad & y(t; \alpha x_0, \delta u) = \alpha y(t; x_0, 0) + \delta y(t; 0, u), \\
 \text{(iii)} \quad & y(t; 0, \delta u_1 + \gamma u_2) = \delta y(t; 0, u_1) + \gamma y(t; 0, u_2).
 \end{aligned} \tag{6.2}$$

Thus, we define a system to be linear if the outputs are jointly linear in the initial condition response ( $u = 0$ ) and the forced response ( $x(0) = 0$ ). Property (iii) is a statement of the *principle of superposition*: the response of a linear system to the sum of two inputs  $u_1$  and  $u_2$  is the sum of the outputs  $y_1$  and  $y_2$  corresponding to the individual inputs.

The general form of a linear state space system is

$$\frac{dx}{dt} = Ax + Bu, \quad y = Cx + Du, \tag{6.3}$$

where  $A \in \mathbb{R}^{n \times n}$ ,  $B \in \mathbb{R}^{n \times p}$ ,  $C \in \mathbb{R}^{q \times n}$  and  $D \in \mathbb{R}^{q \times p}$ . In the special case of a single-input, single-output system,  $B$  is a column vector,  $C$  is a row vector and  $D$  is scalar. Equation (6.3) is a system of linear first-order differential equations with input  $u$ , state  $x$  and output  $y$ . It is easy to show that given solutions  $x_1(t)$  and  $x_2(t)$  for this set of equations, the corresponding outputs satisfy the linearity conditions (6.2).

We define  $x_h(t)$  to be the solution with zero input (the *homogeneous solution*) and the solution  $x_p(t)$  to be the input dependent solution with zero initial condition (the *forced solution* or a *particular solution*). Figure 6.1 illustrates how these two individual solutions can be superimposed to form the complete solution.

It is also possible to show that if a dynamical system with a finite number of states is input/output linear in the sense we have described, it can always be represented by a state space equation of the form (6.3) through an appropriate choice of state variables. In Section 6.2 we will give an explicit solution of equation (6.3), but we illustrate the basic form through a simple example.

### Example 6.1 Scalar system

Consider the first-order differential equation

$$\frac{dx}{dt} = ax + u, \quad y = x,$$

with  $x(0) = x_0$ . Let  $u_1 = A \sin \omega_1 t$  and  $u_2 = B \cos \omega_2 t$ . The homogeneous solution is  $x_h(t) = e^{at} x_0$ , and two particular solutions with  $x(0) = 0$  are

$$x_{p1}(t) = -A \frac{-\omega_1 e^{at} + \omega_1 \cos \omega_1 t + a \sin \omega_1 t}{a^2 + \omega_1^2},$$

$$x_{p2}(t) = B \frac{a e^{at} - a \cos \omega_2 t + \omega_2 \sin \omega_2 t}{a^2 + \omega_2^2}.$$

Suppose that we now choose  $x(0) = \alpha x_0$  and  $u = u_1 + u_2$ . Then the resulting solution is the weighted sum of the individual solutions:

$$x(t) = e^{at} \left( \alpha x_0 + \frac{A \omega_1}{a^2 + \omega_1^2} + \frac{Ba}{a^2 + \omega_2^2} \right) - A \frac{\omega_1 \cos \omega_1 t + a \sin \omega_1 t}{a^2 + \omega_1^2} + B \frac{-a \cos \omega_2 t + \omega_2 \sin \omega_2 t}{a^2 + \omega_2^2}. \quad (6.4)$$

To see this, substitute equation (6.4) into the differential equation. Thus, the properties of a linear system are satisfied.  $\nabla$

### Time Invariance

*Time invariance* is an important concept that is used to describe a system whose properties do not change with time. More precisely, for a time-invariant system if the input  $u(t)$  gives output  $y(t)$ , then if we shift the time at which the input is applied by a constant amount  $a$ ,  $u(t+a)$  gives the output  $y(t+a)$ . Systems that are linear and time-invariant, often called *LTI systems*, have the interesting property that their response to an arbitrary input is completely characterized by their response to step inputs or their response to short “impulses.”

To explore the consequences of time invariance, we first compute the response to a piecewise constant input. Assume that the system is initially at rest and consider the piecewise constant input shown in Figure 6.2a. The input has jumps at times  $t_k$ , and its values after the jumps are  $u(t_k)$ . The input can be viewed as a combination of steps: the first step at time  $t_0$  has amplitude  $u(t_0)$ , the second step at time  $t_1$  has amplitude  $u(t_1) - u(t_0)$ , etc.

Assuming that the system is initially at an equilibrium point (so that the initial condition response is zero), the response to the input can be obtained by superim-

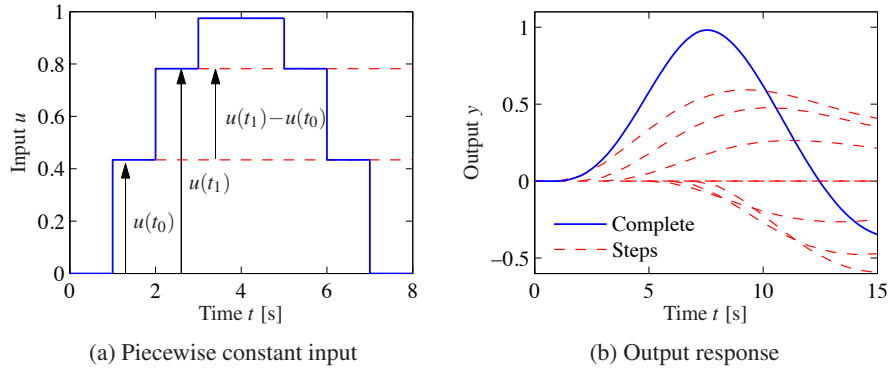

**Figure 6.2:** Response to piecewise constant inputs. A piecewise constant signal can be represented as a sum of step signals (a), and the resulting output is the sum of the individual outputs (b).

posing the responses to a combination of step inputs. Let  $H(t)$  be the response to a unit step applied at time 0. The response to the first step is then  $H(t - t_0)u(t_0)$ , the response to the second step is  $H(t - t_1)(u(t_1) - u(t_0))$ , and we find that the complete response is given by

$$\begin{aligned}
 y(t) &= H(t - t_0)u(t_0) + H(t - t_1)(u(t_1) - u(t_0)) + \cdots \\
 &= (H(t - t_0) - H(t - t_1))u(t_0) + (H(t - t_1) - H(t - t_2))u(t_1) + \cdots \\
 &= \sum_{n=0}^{t_n < t} (H(t - t_n) - H(t - t_{n+1}))u(t_n) \\
 &= \sum_{n=0}^{t_n < t} \frac{H(t - t_n) - H(t - t_{n+1})}{t_{n+1} - t_n} u(t_n) (t_{n+1} - t_n).
 \end{aligned}$$

An example of this computation is shown in Figure 6.2b.

The response to a continuous input signal is obtained by taking the limit as  $t_{n+1} - t_n \rightarrow 0$ , which gives

$$y(t) = \int_0^t H'(t - \tau)u(\tau)d\tau, \quad (6.5)$$

where  $H'$  is the derivative of the step response, also called the *impulse response*. The response of a linear time-invariant system to any input can thus be computed from the step response. Notice that the output depends only on the input since we assumed the system was initially at rest,  $x(0) = 0$ . We will derive equation (6.5) in a slightly different way in the Section 6.3.

## 6.2 The Matrix Exponential

Equation (6.5) shows that the output of a linear system with zero initial state can be written as an integral over the inputs  $u(t)$ . In this section and the next we derive a more general version of this formula, which includes nonzero initial conditions. We begin by exploring the initial condition response using the matrix exponential.

### Initial Condition Response

We will now show explicitly show the output of a linear system depends on the input and the initial conditions. We begin by considering the homogeneous response corresponding to the system

$$\frac{dx}{dt} = Ax. \quad (6.6)$$

For the *scalar* differential equation

$$\frac{dx}{dt} = ax, \quad x \in \mathbb{R}, a \in \mathbb{R},$$

the solution is given by the exponential

$$x(t) = e^{at}x(0).$$

We wish to generalize this to the vector case, where  $A$  becomes a matrix. We define the *matrix exponential* as the infinite series

$$e^X = I + X + \frac{1}{2}X^2 + \frac{1}{3!}X^3 + \cdots = \sum_{k=0}^{\infty} \frac{1}{k!}X^k, \quad (6.7)$$

where  $X \in \mathbb{R}^{n \times n}$  is a square matrix and  $I$  is the  $n \times n$  identity matrix. We make use of the notation

$$X^0 = I, \quad X^2 = XX, \quad X^n = X^{n-1}X,$$

which defines what we mean by the “power” of a matrix. Equation (6.7) is easy to remember since it is just the Taylor series for the scalar exponential, applied to the matrix  $X$ . It can be shown that the series in equation (6.7) converges for any matrix  $X \in \mathbb{R}^{n \times n}$  in the same way that the normal exponential is defined for any scalar  $a \in \mathbb{R}$ .

Replacing  $X$  in equation (6.7) by  $At$ , where  $t \in \mathbb{R}$ , we find that

$$e^{At} = I + At + \frac{1}{2}A^2t^2 + \frac{1}{3!}A^3t^3 + \cdots = \sum_{k=0}^{\infty} \frac{1}{k!}A^k t^k,$$

and differentiating this expression with respect to  $t$  gives

$$\frac{d}{dt}e^{At} = A + A^2t + \frac{1}{2}A^3t^2 + \cdots = A \sum_{k=0}^{\infty} \frac{1}{k!}A^k t^k = Ae^{At}. \quad (6.8)$$

Multiplying by  $x(0)$  from the right, we find that  $x(t) = e^{At}x(0)$  is the solution to the differential equation (6.6) with initial condition  $x(0)$ . We summarize this important result as a proposition.



**Proposition 6.1.** *The solution to the homogeneous system of differential equations (6.6) is given by*

$$x(t) = e^{At}x(0).$$

Notice that the form of the solution is exactly the same as for scalar equations, but we must put the vector  $x(0)$  on the right of the matrix  $e^{At}$ .

The form of the solution immediately allows us to see that the solution is linear in the initial condition. In particular, if  $x_{h1}(t)$  is the solution to equation (6.6) with initial condition  $x(0) = x_{01}$  and  $x_{h2}(t)$  with initial condition  $x(0) = x_{02}$ , then the solution with initial condition  $x(0) = \alpha x_{01} + \beta x_{02}$  is given by

$$x(t) = e^{At}(\alpha x_{01} + \beta x_{02}) = (\alpha e^{At}x_{01} + \beta e^{At}x_{02}) = \alpha x_{h1}(t) + \beta x_{h2}(t).$$

Similarly, we see that the corresponding output is given by

$$y(t) = Cx(t) = \alpha y_{h1}(t) + \beta y_{h2}(t),$$

where  $y_{h1}(t)$  and  $y_{h2}(t)$  are the outputs corresponding to  $x_{h1}(t)$  and  $x_{h2}(t)$ .

We illustrate computation of the matrix exponential by two examples.

**Example 6.2 Double integrator**

A very simple linear system that is useful in understanding basic concepts is the second-order system given by

$$\ddot{q} = u, \quad y = q.$$

This system is called a *double integrator* because the input  $u$  is integrated twice to determine the output  $y$ .

In state space form, we write  $x = (q, \dot{q})$  and

$$\frac{dx}{dt} = \begin{pmatrix} 0 & 1 \\ 0 & 0 \end{pmatrix} x + \begin{pmatrix} 0 \\ 1 \end{pmatrix} u.$$

The dynamics matrix of a double integrator is

$$A = \begin{pmatrix} 0 & 1 \\ 0 & 0 \end{pmatrix},$$

and we find by direct calculation that  $A^2 = 0$  and hence

$$e^{At} = \begin{pmatrix} 1 & t \\ 0 & 1 \end{pmatrix}.$$

Thus the homogeneous solution ( $u = 0$ ) for the double integrator is given by

$$x(t) = \begin{pmatrix} 1 & t \\ 0 & 1 \end{pmatrix} \begin{pmatrix} x_1(0) \\ x_2(0) \end{pmatrix} = \begin{pmatrix} x_1(0) + tx_2(0) \\ x_2(0) \end{pmatrix},$$

$$y(t) = x_1(0) + tx_2(0).$$

▽

**Example 6.3 Undamped oscillator**

A model for an oscillator, such as the spring–mass system with zero damping, is

$$\ddot{q} + \omega_0^2 q = u.$$

Putting the system into state space form using  $x_1 = q$ ,  $x_2 = \dot{q}/\omega_0$ , the dynamics matrix for this system can be written as

$$A = \begin{pmatrix} 0 & \omega_0 \\ -\omega_0 & 0 \end{pmatrix} \quad \text{and} \quad e^{At} = \begin{pmatrix} \cos \omega_0 t & \sin \omega_0 t \\ -\sin \omega_0 t & \cos \omega_0 t \end{pmatrix}.$$

This expression for  $e^{At}$  can be verified by differentiation:

$$\begin{aligned} \frac{d}{dt} e^{At} &= \begin{pmatrix} -\omega_0 \sin \omega_0 t & \omega_0 \cos \omega_0 t \\ -\omega_0 \cos \omega_0 t & -\omega_0 \sin \omega_0 t \end{pmatrix} \\ &= \begin{pmatrix} 0 & \omega_0 \\ -\omega_0 & 0 \end{pmatrix} \begin{pmatrix} \cos \omega_0 t & \sin \omega_0 t \\ -\sin \omega_0 t & \cos \omega_0 t \end{pmatrix} = A e^{At}. \end{aligned}$$

The solution is then given by

$$x(t) = e^{At} x(0) = \begin{pmatrix} \cos \omega_0 t & \sin \omega_0 t \\ -\sin \omega_0 t & \cos \omega_0 t \end{pmatrix} \begin{pmatrix} x_1(0) \\ x_2(0) \end{pmatrix}.$$

The solution is more complicated if the system has damping:

$$\ddot{q} + 2\zeta \omega_0 \dot{q} + \omega_0^2 q = u.$$

If  $\zeta < 1$  we have

$$\exp \begin{pmatrix} -\zeta \omega_0 & \omega_d \\ -\omega_d & -\zeta \omega_0 \end{pmatrix} t = e^{-\zeta \omega_0 t} \begin{pmatrix} \cos \omega_d t & \sin \omega_d t \\ -\sin \omega_d t & \cos \omega_d t \end{pmatrix}.$$

where  $\omega_d = \omega_0 \sqrt{1 - \zeta^2}$ . The result can be proven by differentiating the exponential matrix. The corresponding results for  $\zeta \geq 1$  are given in Exercise 6.4.  $\nabla$

An important class of linear systems are those that can be converted into diagonal form by a linear change of coordinates. Suppose that we are given a system

$$\frac{dx}{dt} = Ax$$

such that all the eigenvalues of  $A$  are distinct. It can be shown (Exercise 5.14) that there exists an invertible matrix  $T$  such that  $TAT^{-1}$  is diagonal. If we choose a set of coordinates  $z = Tx$ , then in the new coordinates the dynamics become

$$\frac{dz}{dt} = T \frac{dx}{dt} = TAx = TAT^{-1}z.$$

By definition of  $T$ , this system will be diagonal.

Now consider a diagonal matrix  $A$  and the corresponding  $k$ th power of  $At$ , which is also diagonal:

$$A = \begin{pmatrix} \lambda_1 & & & 0 \\ & \lambda_2 & & \\ & & \ddots & \\ 0 & & & \lambda_n \end{pmatrix}, \quad (At)^k = \begin{pmatrix} \lambda_1^k t^k & & & 0 \\ & \lambda_2^k t^k & & \\ & & \ddots & \\ 0 & & & \lambda_n^k t^k \end{pmatrix},$$

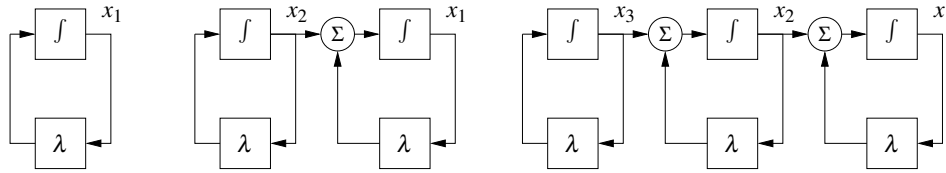

**Figure 6.3:** Representations of linear systems where the dynamics matrices are Jordan blocks. A first-order Jordan block can be represented as an integrator with feedback  $\lambda$ , as shown on the left. Second- and third-order Jordan blocks can be represented as series connections of integrators with identical feedback, as shown on the right.

It follows from the series expansion that the matrix exponential is given by

$$e^{At} = \begin{pmatrix} e^{\lambda_1 t} & & & 0 \\ & e^{\lambda_2 t} & & \\ & & \ddots & \\ 0 & & & e^{\lambda_n t} \end{pmatrix}.$$

A similar expansion can be done in the case where the eigenvalues are complex, using a block diagonal matrix, similar to what was done in Section 5.3.

### Jordan Form



Some matrices with repeated eigenvalues cannot be transformed to diagonal form. They can, however, be transformed to a closely related form, called the *Jordan form*, in which the dynamics matrix has the eigenvalues along the diagonal. When there are equal eigenvalues, there may be 1's appearing in the superdiagonal indicating that there is coupling between the states.

Specifically, we define a matrix to be in Jordan form if it can be written as

$$J = \begin{pmatrix} J_1 & 0 & \dots & 0 & 0 \\ 0 & J_2 & \ddots & 0 & 0 \\ \vdots & & \ddots & \ddots & \vdots \\ 0 & 0 & & J_{k-1} & 0 \\ 0 & 0 & \dots & 0 & J_k \end{pmatrix}, \quad \text{where } J_i = \begin{pmatrix} \lambda_i & 1 & 0 & \dots & 0 \\ 0 & \lambda_i & 1 & & 0 \\ \vdots & & \ddots & \ddots & \vdots \\ 0 & 0 & & \lambda_i & 1 \\ 0 & 0 & \dots & 0 & \lambda_i \end{pmatrix}, \quad (6.9)$$

where  $\lambda_i$  is an eigenvalue of  $J_i$ . Each matrix  $J_i$  is called a *Jordan block*. A first-order Jordan block can be represented as a system consisting of an integrator with feedback  $\lambda$ . A Jordan block of higher order can be represented as series connections of such systems, as illustrated in Figure 6.3.

**Theorem 6.2** (Jordan decomposition). *Any matrix  $A \in \mathbb{R}^{n \times n}$  can be transformed into Jordan form with the eigenvalues of  $A$  determining  $\lambda_i$  in the Jordan form.*

*Proof.* See any standard text on linear algebra, such as Strang [Str88]. The special case where the eigenvalues are distinct is examined in Exercise 5.14.  $\square$

Converting a matrix into Jordan form can be complicated, although MATLAB can do this conversion for numerical matrices using the `jordan` function. There is no requirement that the individual  $\lambda_i$ 's be distinct, and hence for a given eigenvalue we can have one or more Jordan blocks of different sizes.

Once a matrix is in Jordan form, the exponential of the matrix can be computed in terms of the Jordan blocks:

$$e^{Jt} = \begin{pmatrix} e^{J_1 t} & 0 & \dots & 0 \\ 0 & e^{J_2 t} & & \vdots \\ \vdots & & \ddots & 0 \\ 0 & \dots & 0 & e^{J_k t} \end{pmatrix}. \quad (6.10)$$

This follows from the block diagonal form of  $J$ . The exponentials of the Jordan blocks can in turn be written as

$$e^{J_i t} = \begin{pmatrix} 1 & t & \frac{t^2}{2!} & \dots & \frac{t^{n-1}}{(n-1)!} \\ 0 & 1 & t & \dots & \frac{t^{n-2}}{(n-2)!} \\ \vdots & & 1 & \ddots & \vdots \\ & & & \ddots & t \\ 0 & \dots & 0 & 0 & 1 \end{pmatrix} e^{\lambda_i t}. \quad (6.11)$$

When there are multiple eigenvalues, the invariant subspaces associated with each eigenvalue correspond to the Jordan blocks of the matrix  $A$ . Note that some eigenvalues of  $A$  may be complex, in which case the transformation  $T$  that converts a matrix into Jordan form will also be complex. When  $\lambda$  has a nonzero imaginary component, the solutions will have oscillatory components since

$$e^{(\sigma+i\omega)t} = e^{\sigma t} (\cos \omega t + i \sin \omega t).$$

We can now use these results to prove Theorem 5.1, which states that the equilibrium point  $x_e = 0$  of a linear system is asymptotically stable if and only if  $\operatorname{Re} \lambda_i < 0$  for all  $i$ .

*Proof of Theorem 5.1.* Let  $T \in \mathbb{C}^{n \times n}$  be an invertible matrix that transforms  $A$  into Jordan form,  $J = TAT^{-1}$ . Using coordinates  $z = Tx$ , we can write the solution  $z(t)$  as

$$z(t) = e^{Jt} z(0),$$

where  $z(0) = Tx(0)$ , so that  $x(t) = T^{-1} e^{Jt} z(0)$ .

The solution  $z(t)$  can be written in terms of the elements of the matrix exponential. From equation (6.11) these elements all decay to zero for arbitrary  $z(0)$  if and only if  $\operatorname{Re} \lambda_i < 0$  for all  $i$ . Furthermore, if any  $\lambda_i$  has positive real part, then there exists an initial condition  $z(0)$  such that the corresponding solution increases without bound. Since we can scale this initial condition to be arbitrarily small, it follows that the equilibrium point is unstable if any eigenvalue has positive real part.  $\square$

The existence of a canonical form allows us to prove many properties of linear systems by changing to a set of coordinates in which the  $A$  matrix is in Jordan form. We illustrate this in the following proposition, which follows along the same lines as the proof of Theorem 5.1.

**Proposition 6.3.** *Suppose that the system*

$$\frac{dx}{dt} = Ax$$

*has no eigenvalues with strictly positive real part and one or more eigenvalues with zero real part. Then the system is stable if and only if the Jordan blocks corresponding to each eigenvalue with zero real part are scalar ( $1 \times 1$ ) blocks.*

*Proof.* See Exercise 6.6b. □

The following example illustrates the use of the Jordan form.

**Example 6.4 Linear model of a vectored thrust aircraft**

Consider the dynamics of a vectored thrust aircraft such as that described in Example 3.11. Suppose that we choose  $u_1 = u_2 = 0$  so that the dynamics of the system become

$$\frac{dz}{dt} = \begin{pmatrix} z_4 \\ z_5 \\ z_6 \\ -g \sin z_3 - \frac{c}{m} z_4 \\ g(\cos z_3 - 1) - \frac{c}{m} z_5 \\ 0 \end{pmatrix}, \quad (6.12)$$

where  $z = (x, y, \theta, \dot{x}, \dot{y}, \dot{\theta})$ . The equilibrium points for the system are given by setting the velocities  $\dot{x}$ ,  $\dot{y}$  and  $\dot{\theta}$  to zero and choosing the remaining variables to satisfy

$$\begin{aligned} -g \sin z_{3,e} &= 0 \\ g(\cos z_{3,e} - 1) &= 0 \end{aligned} \quad \implies \quad z_{3,e} = \theta_e = 0.$$

This corresponds to the upright orientation for the aircraft. Note that  $x_e$  and  $y_e$  are not specified. This is because we can translate the system to a new (upright) position and still obtain an equilibrium point.

To compute the stability of the equilibrium point, we compute the linearization using equation (5.11):

$$A = \left. \frac{\partial F}{\partial z} \right|_{z_e} = \begin{pmatrix} 0 & 0 & 0 & 1 & 0 & 0 \\ 0 & 0 & 0 & 0 & 1 & 0 \\ 0 & 0 & 0 & 0 & 0 & 1 \\ 0 & 0 & -g & -c/m & 0 & 0 \\ 0 & 0 & 0 & 0 & -c/m & 0 \\ 0 & 0 & 0 & 0 & 0 & 0 \end{pmatrix}.$$

The eigenvalues of the system can be computed as

$$\lambda(A) = \{0, 0, 0, 0, -c/m, -c/m\}.$$

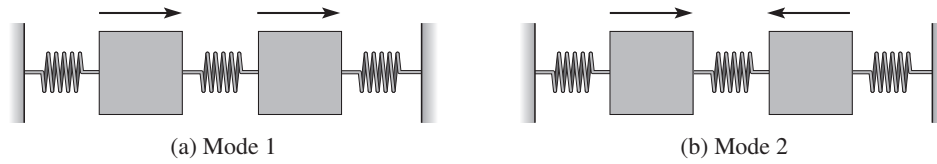

**Figure 6.4:** Modes of vibration for a system consisting of two masses connected by springs. In (a) the masses move left and right in synchronization in (b) they move toward or against each other.

We see that the linearized system is not asymptotically stable since not all of the eigenvalues have strictly negative real part.

To determine whether the system is stable in the sense of Lyapunov, we must make use of the Jordan form. It can be shown that the Jordan form of  $A$  is given by

$$J = \left( \begin{array}{cccc|cc} 0 & 0 & 0 & 0 & 0 & 0 \\ 0 & 0 & 1 & 0 & 0 & 0 \\ 0 & 0 & 0 & 1 & 0 & 0 \\ 0 & 0 & 0 & 0 & 0 & 0 \\ \hline 0 & 0 & 0 & 0 & -c/m & 0 \\ 0 & 0 & 0 & 0 & 0 & -c/m \end{array} \right).$$

Since the second Jordan block has eigenvalue 0 and is not a simple eigenvalue, the linearization is unstable.  $\nabla$

### Eigenvalues and Modes

The eigenvalues and eigenvectors of a system provide a description of the types of behavior the system can exhibit. For oscillatory systems, the term *mode* is often used to describe the vibration patterns that can occur. Figure 6.4 illustrates the modes for a system consisting of two masses connected by springs. One pattern is when both masses oscillate left and right in unison, and another is when the masses move toward and away from each other.

The initial condition response of a linear system can be written in terms of a matrix exponential involving the dynamics matrix  $A$ . The properties of the matrix  $A$  therefore determine the resulting behavior of the system. Given a matrix  $A \in \mathbb{R}^{n \times n}$ , recall that  $v$  is an eigenvector of  $A$  with eigenvalue  $\lambda$  if

$$Av = \lambda v.$$

In general  $\lambda$  and  $v$  may be complex-valued, although if  $A$  is real-valued, then for any eigenvalue  $\lambda$  its complex conjugate  $\lambda^*$  will also be an eigenvalue (with  $v^*$  as the corresponding eigenvector).

Suppose first that  $\lambda$  and  $v$  are a real-valued eigenvalue/eigenvector pair for  $A$ . If we look at the solution of the differential equation for  $x(0) = v$ , it follows from

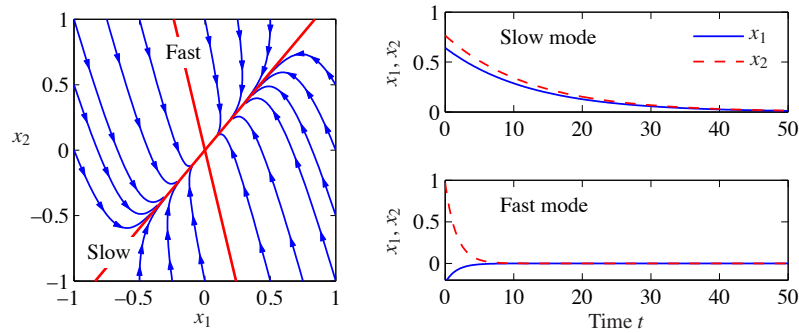

**Figure 6.5:** The notion of modes for a second-order system with real eigenvalues. The left figure shows the phase portrait and the modes corresponding to solutions that start on the eigenvectors (bold lines). The corresponding time functions are shown on the right.

the definition of the matrix exponential that

$$e^{At}v = \left(I + At + \frac{1}{2}A^2t^2 + \dots\right)v = v + \lambda tv + \frac{\lambda^2 t^2}{2}v + \dots = e^{\lambda t}v.$$

The solution thus lies in the subspace spanned by the eigenvector. The eigenvalue  $\lambda$  describes how the solution varies in time, and this solution is often called a *mode* of the system. (In the literature, the term “mode” is also often used to refer to the eigenvalue rather than the solution.)

If we look at the individual elements of the vectors  $x$  and  $v$ , it follows that

$$\frac{x_i(t)}{x_j(t)} = \frac{e^{\lambda t}v_i}{e^{\lambda t}v_j} = \frac{v_i}{v_j},$$

and hence the ratios of the components of the state  $x$  are constants for a (real) mode. The eigenvector thus gives the “shape” of the solution and is also called a *mode shape* of the system. Figure 6.5 illustrates the modes for a second-order system consisting of a fast mode and a slow mode. Notice that the state variables have the same sign for the slow mode and different signs for the fast mode.

The situation is more complicated when the eigenvalues of  $A$  are complex. Since  $A$  has real elements, the eigenvalues and the eigenvectors are complex conjugates  $\lambda = \sigma \pm i\omega$  and  $v = u \pm iw$ , which implies that

$$u = \frac{v + v^*}{2}, \quad w = \frac{v - v^*}{2i}.$$

Making use of the matrix exponential, we have

$$e^{At}v = e^{\lambda t}(u + iw) = e^{\sigma t}((u \cos \omega t - w \sin \omega t) + i(u \sin \omega t + w \cos \omega t)),$$

from which it follows that

$$\begin{aligned} e^{At}u &= \frac{1}{2} \left( e^{At}v + e^{At}v^* \right) = ue^{\sigma t} \cos \omega t - we^{\sigma t} \sin \omega t, \\ e^{At}w &= \frac{1}{2i} \left( e^{At}v - e^{At}v^* \right) = ue^{\sigma t} \sin \omega t + we^{\sigma t} \cos \omega t. \end{aligned}$$

A solution with initial conditions in the subspace spanned by the real part  $u$  and imaginary part  $w$  of the eigenvector will thus remain in that subspace. The solution will be a logarithmic spiral characterized by  $\sigma$  and  $\omega$ . We again call the solution corresponding to  $\lambda$  a mode of the system, and  $v$  the mode shape.

If a matrix  $A$  has  $n$  distinct eigenvalues  $\lambda_1, \dots, \lambda_n$ , then the initial condition response can be written as a linear combination of the modes. To see this, suppose for simplicity that we have all real eigenvalues with corresponding unit eigenvectors  $v_1, \dots, v_n$ . From linear algebra, these eigenvectors are linearly independent, and we can write the initial condition  $x(0)$  as

$$x(0) = \alpha_1 v_1 + \alpha_2 v_2 + \dots + \alpha_n v_n.$$

Using linearity, the initial condition response can be written as

$$x(t) = \alpha_1 e^{\lambda_1 t} v_1 + \alpha_2 e^{\lambda_2 t} v_2 + \dots + \alpha_n e^{\lambda_n t} v_n.$$

Thus, the response is a linear combination of the modes of the system, with the amplitude of the individual modes growing or decaying as  $e^{\lambda_i t}$ . The case for distinct complex eigenvalues follows similarly (the case for nondistinct eigenvalues is more subtle and requires making use of the Jordan form discussed in the previous section).

### Example 6.5 Coupled spring–mass system

Consider the spring–mass system shown in Figure 6.4, but with the addition of dampers on each mass. The equations of motion of the system are

$$m\ddot{q}_1 = -2kq_1 - c\dot{q}_1 + kq_2, \quad m\ddot{q}_2 = kq_1 - 2kq_2 - c\dot{q}_2.$$

In state space form, we define the state to be  $x = (q_1, q_2, \dot{q}_1, \dot{q}_2)$ , and we can rewrite the equations as

$$\frac{dx}{dt} = \begin{pmatrix} 0 & 0 & 1 & 0 \\ 0 & 0 & 0 & 1 \\ -\frac{2k}{m} & \frac{k}{m} & -\frac{c}{m} & 0 \\ \frac{k}{m} & -\frac{2k}{m} & 0 & -\frac{c}{m} \end{pmatrix} x.$$

We now define a transformation  $z = Tx$  that puts this system into a simpler form.



Let  $z_1 = \frac{1}{2}(q_1 + q_2)$ ,  $z_2 = \dot{z}_1$ ,  $z_3 = \frac{1}{2}(q_1 - q_2)$  and  $z_4 = \dot{z}_3$ , so that

$$z = Tx = \frac{1}{2} \begin{pmatrix} 1 & 1 & 0 & 0 \\ 0 & 0 & 1 & 1 \\ 1 & -1 & 0 & 0 \\ 0 & 0 & 1 & -1 \end{pmatrix} x.$$

In the new coordinates, the dynamics become

$$\frac{dz}{dt} = \begin{pmatrix} 0 & 1 & 0 & 0 \\ -\frac{k}{m} & -\frac{c}{m} & 0 & 0 \\ 0 & 0 & 0 & 1 \\ 0 & 0 & -\frac{3k}{m} & -\frac{c}{m} \end{pmatrix} z,$$

and we see that the system is in block diagonal form.

In the  $z$  coordinates, the states  $z_1$  and  $z_2$  parameterize one mode with eigenvalues  $\lambda \approx -c/(2m) \pm i\sqrt{k}/m$ , and the states  $z_3$  and  $z_4$  another mode with  $\lambda \approx -c/(2m) \pm i\sqrt{3k}/m$ . From the form of the transformation  $T$  we see that these modes correspond exactly to the modes in Figure 6.4, in which  $q_1$  and  $q_2$  move either toward or against each other. The real and imaginary parts of the eigenvalues give the decay rates  $\sigma$  and frequencies  $\omega$  for each mode.  $\nabla$

### 6.3 Input/Output Response

In the previous section we saw how to compute the initial condition response using the matrix exponential. In this section we derive the convolution equation, which includes the inputs and outputs as well.

#### The Convolution Equation

We return to the general input/output case in equation (6.3), repeated here:

$$\frac{dx}{dt} = Ax + Bu, \quad y = Cx + Du. \quad (6.13)$$

Using the matrix exponential, the solution to equation (6.13) can be written as follows.

**Theorem 6.4.** *The solution to the linear differential equation (6.13) is given by*

$$x(t) = e^{At}x(0) + \int_0^t e^{A(t-\tau)}Bu(\tau)d\tau. \quad (6.14)$$

*Proof.* To prove this, we differentiate both sides and use the property (6.8) of the matrix exponential. This gives

$$\frac{dx}{dt} = Ae^{At}x(0) + \int_0^t Ae^{A(t-\tau)}Bu(\tau)d\tau + Bu(t) = Ax + Bu,$$

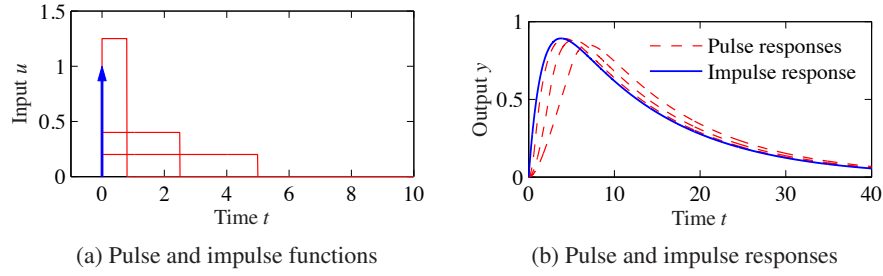

**Figure 6.6:** Pulse response and impulse response. (a) The rectangles show pulses of width 5, 2.5 and 0.8, each with total area equal to 1. The arrow denotes an impulse  $\delta(t)$  defined by equation (6.17). The corresponding pulse responses for a linear system with eigenvalues  $\lambda = \{-0.08, -0.62\}$  are shown in (b) as dashed lines. The solid line is the true impulse response, which is well approximated by a pulse of duration 0.8.

which proves the result since the initial conditions are also met. Notice that the calculation is essentially the same as for proving the result for a first-order equation.  $\square$

It follows from equations (6.13) and (6.14) that the input/output relation for a linear system is given by

$$y(t) = Ce^{At}x(0) + \int_0^t Ce^{A(t-\tau)}Bu(\tau)d\tau + Du(t). \quad (6.15)$$

It is easy to see from this equation that the output is jointly linear in both the initial conditions and the input, which follows from the linearity of matrix/vector multiplication and integration.

Equation (6.15) is called the *convolution equation*, and it represents the general form of the solution of a system of coupled linear differential equations. We see immediately that the dynamics of the system, as characterized by the matrix  $A$ , play a critical role in both the stability and performance of the system. Indeed, the matrix exponential describes *both* what happens when we perturb the initial condition and how the system responds to inputs.



Another interpretation of the convolution equation can be given using the concept of the *impulse response* of a system. Consider the application of an input signal  $u(t)$  given by the following equation:

$$u(t) = p_\varepsilon(t) = \begin{cases} 0 & t < 0 \\ 1/\varepsilon & 0 \leq t < \varepsilon \\ 0 & t \geq \varepsilon. \end{cases} \quad (6.16)$$

This signal is a *pulse* of duration  $\varepsilon$  and amplitude  $1/\varepsilon$ , as illustrated in Figure 6.6a. We define an *impulse*  $\delta(t)$  to be the limit of this signal as  $\varepsilon \rightarrow 0$ :

$$\delta(t) = \lim_{\varepsilon \rightarrow 0} p_\varepsilon(t). \quad (6.17)$$

This signal, sometimes called a *delta function*, is not physically achievable but provides a convenient abstraction in understanding the response of a system. Note that the integral of an impulse is 1:

$$\begin{aligned}\int_0^t \delta(\tau) d\tau &= \int_0^t \lim_{\varepsilon \rightarrow 0} p_\varepsilon(t) d\tau = \lim_{\varepsilon \rightarrow 0} \int_0^t p_\varepsilon(t) d\tau \\ &= \lim_{\varepsilon \rightarrow 0} \int_0^\varepsilon 1/\varepsilon d\tau = 1 \quad t > 0.\end{aligned}$$

In particular, the integral of an impulse over an arbitrarily short period of time that includes the origin is identically 1.

We define the *impulse response*  $h(t)$  for a system as the output of the system with zero initial condition and having an impulse as its input:

$$h(t) = \int_0^t C e^{A(t-\tau)} B \delta(\tau) d\tau = C e^{At} B, \quad (6.18)$$

where the second equality follows from the fact that  $\delta(t)$  is zero everywhere except the origin and its integral is identically 1. We can now write the convolution equation in terms of the initial condition response, the convolution of the impulse response and the input signal, and the direct term:

$$y(t) = C e^{At} x(0) + \int_0^t h(t-\tau) u(\tau) d\tau + D u(t). \quad (6.19)$$

One interpretation of this equation, explored in Exercise 6.2, is that the response of the linear system is the superposition of the response to an infinite set of shifted impulses whose magnitudes are given by the input  $u(t)$ . This is essentially the argument used in analyzing Figure 6.2 and deriving equation (6.5). Note that the second term in equation (6.19) is identical to equation (6.5), and it can be shown that the impulse response is the derivative of the step response.

The use of pulses  $p_\varepsilon(t)$  as approximations of the impulse function  $\delta(t)$  also provides a mechanism for identifying the dynamics of a system from experiments. Figure 6.6b shows the pulse responses of a system for different pulse widths. Notice that the pulse responses approach the impulse response as the pulse width goes to zero. As a general rule, if the fastest eigenvalue of a stable system has real part  $-\sigma_{\max}$ , then a pulse of length  $\varepsilon$  will provide a good estimate of the impulse response if  $\varepsilon \sigma_{\max} \ll 1$ . Note that for Figure 6.6, a pulse width of  $\varepsilon = 1$  s gives  $\varepsilon \sigma_{\max} = 0.62$  and the pulse response is already close to the impulse response.

### Coordinate Invariance

The components of the input vector  $u$  and the output vector  $y$  are determined by the chosen inputs and outputs of a model, but the state variables depend on the coordinate frame chosen to represent the state. This choice of coordinates affects the values of the matrices  $A$ ,  $B$  and  $C$  that are used in the model. (The direct term  $D$  is not affected since it maps inputs to outputs.) We now investigate some of the consequences of changing coordinate systems.

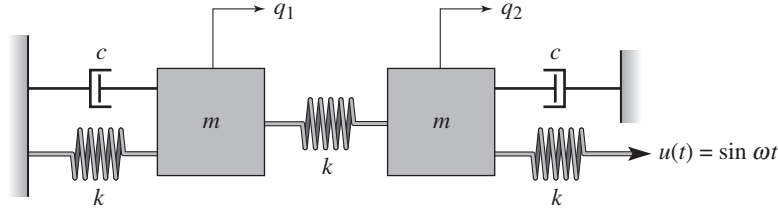

**Figure 6.7:** Coupled spring mass system. Each mass is connected to two springs with stiffness  $k$  and a viscous damper with damping coefficient  $c$ . The mass on the right is driven through a spring connected to a sinusoidally varying attachment.

Introduce new coordinates  $z$  by the transformation  $z = Tx$ , where  $T$  is an invertible matrix. It follows from equation (6.3) that

$$\begin{aligned}\frac{dz}{dt} &= T(Ax + Bu) = TAT^{-1}z + TBu =: \tilde{A}z + \tilde{B}u, \\ y &= Cx + Du = CT^{-1}z + Du =: \tilde{C}z + Du.\end{aligned}$$

The transformed system has the same form as equation (6.3), but the matrices  $A$ ,  $B$  and  $C$  are different:

$$\tilde{A} = TAT^{-1}, \quad \tilde{B} = TB, \quad \tilde{C} = CT^{-1}. \quad (6.20)$$

There are often special choices of coordinate systems that allow us to see a particular property of the system, hence coordinate transformations can be used to gain new insight into the dynamics. The eigenvalues of  $\tilde{A}$  are the same as those of  $A$ , so stability is not affected.

We can also compare the solution of the system in transformed coordinates to that in the original state coordinates. We make use of an important property of the exponential map,

$$e^{TST^{-1}} = Te^ST^{-1},$$

which can be verified by substitution in the definition of the matrix exponential. Using this property, it is easy to show that

$$x(t) = T^{-1}z(t) = T^{-1}e^{\tilde{A}t}Tx(0) + T^{-1}\int_0^t e^{\tilde{A}(t-\tau)}\tilde{B}u(\tau)d\tau.$$

From this form of the equation, we see that if it is possible to transform  $A$  into a form  $\tilde{A}$  for which the matrix exponential is easy to compute, we can use that computation to solve the general convolution equation for the untransformed state  $x$  by simple matrix multiplications. This technique is illustrated in the following example.

### Example 6.6 Coupled spring–mass system

Consider the coupled spring–mass system shown in Figure 6.7. The input to this system is the sinusoidal motion of the position of the rightmost spring, and the output is the position of each mass,  $q_1$  and  $q_2$ . The equations of motion are given

by

$$m\ddot{q}_1 = -2kq_1 - c\dot{q}_1 + kq_2, \quad m\ddot{q}_2 = kq_1 - 2kq_2 - c\dot{q}_2 + ku.$$

In state space form, we define the state to be  $x = (q_1, q_2, \dot{q}_1, \dot{q}_2)$ , and we can rewrite the equations as

$$\frac{dx}{dt} = \begin{pmatrix} 0 & 0 & 1 & 0 \\ 0 & 0 & 0 & 1 \\ -\frac{2k}{m} & \frac{k}{m} & -\frac{c}{m} & 0 \\ \frac{k}{m} & -\frac{2k}{m} & 0 & -\frac{c}{m} \end{pmatrix} x + \begin{pmatrix} 0 \\ 0 \\ 0 \\ \frac{k}{m} \end{pmatrix} u.$$

This is a coupled set of four differential equations and is quite complicated to solve in analytical form.

The dynamics matrix is the same as in Example 6.5, and we can use the coordinate transformation defined there to put the system in block diagonal form:

$$\frac{dz}{dt} = \begin{pmatrix} 0 & 1 & 0 & 0 \\ -\frac{k}{m} & -\frac{c}{m} & 0 & 0 \\ 0 & 0 & 0 & 1 \\ 0 & 0 & -\frac{3k}{m} & -\frac{c}{m} \end{pmatrix} z + \begin{pmatrix} 0 \\ \frac{k}{2m} \\ 0 \\ -\frac{k}{2m} \end{pmatrix} u.$$

Note that the resulting matrix equations are block diagonal and hence decoupled. We can solve for the solutions by computing the solutions of two sets of second-order systems represented by the states  $(z_1, z_2)$  and  $(z_3, z_4)$ . Indeed, the functional form of each set of equations is identical to that of a single spring–mass system. (The explicit solution is derived in Section 7.3.)

Once we have solved the two sets of independent second-order equations, we can recover the dynamics in the original coordinates by inverting the state transformation and writing  $x = T^{-1}z$ . We can also determine the stability of the system by looking at the stability of the independent second-order systems.  $\nabla$

### Steady-State Response

Given a linear input/output system

$$\frac{dx}{dt} = Ax + Bu, \quad y = Cx + Du, \quad (6.21)$$

the general form of the solution to equation (6.21) is given by the convolution equation:

$$y(t) = Ce^{At}x(0) + \int_0^t Ce^{A(t-\tau)}Bu(\tau)d\tau + Du(t).$$

We see from the form of this equation that the solution consists of an initial condition response and an input response.

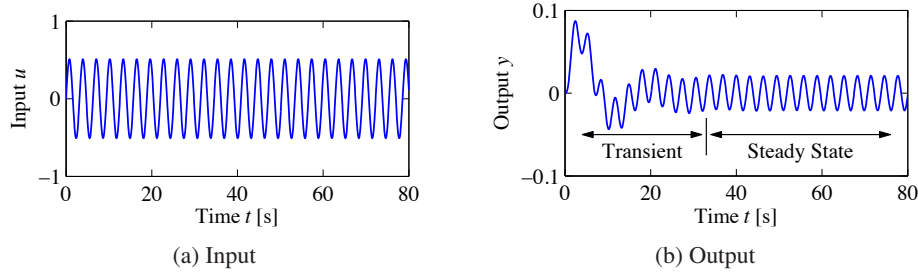

**Figure 6.8:** Transient versus steady-state response. The input to a linear system is shown in (a), and the corresponding output with  $x(0) = 0$  is shown in (b). The output signal initially undergoes a transient before settling into its steady-state behavior.

The input response, corresponding to the last two terms in the equation above, itself consists of two components—the *transient response* and the *steady-state response*. The transient response occurs in the first period of time after the input is applied and reflects the mismatch between the initial condition and the steady-state solution. The steady-state response is the portion of the output response that reflects the long-term behavior of the system under the given inputs. For inputs that are periodic the steady-state response will often be periodic, and for constant inputs the response will often be constant. An example of the transient and the steady-state response for a periodic input is shown in Figure 6.8.

A particularly common form of input is a *step input*, which represents an abrupt change in input from one value to another. A *unit step* (sometimes called the Heaviside step function) is defined as

$$u(t) = S(t) = \begin{cases} 0 & t = 0 \\ 1 & t > 0. \end{cases}$$

The *step response* of the system (6.21) is defined as the output  $y(t)$  starting from zero initial condition (or the appropriate equilibrium point) and given a step input. We note that the step input is discontinuous and hence is not practically implementable. However, it is a convenient abstraction that is widely used in studying input/output systems.

We can compute the step response to a linear system using the convolution equation. Setting  $x(0) = 0$  and using the definition of the step input above, we have

$$\begin{aligned} y(t) &= \int_0^t C e^{A(t-\tau)} B u(\tau) d\tau + D u(t) = C \int_0^t e^{A(t-\tau)} B d\tau + D \\ &= C \int_0^t e^{A\sigma} B d\sigma + D = C (A^{-1} e^{A\sigma} B) \Big|_{\sigma=0}^{\sigma=t} + D \\ &= C A^{-1} e^{At} B - C A^{-1} B + D. \end{aligned}$$

If all eigenvalues of  $A$  have negative real parts (implying that the origin is a stable

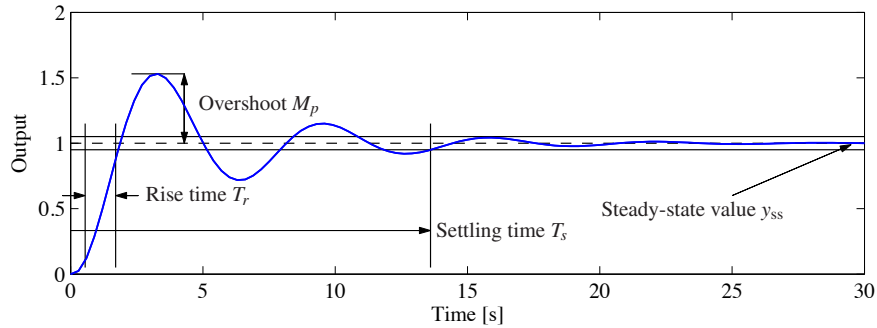

**Figure 6.9:** Sample step response. The rise time, overshoot, settling time and steady-state value give the key performance properties of the signal.

equilibrium point in the absence of any input), then we can rewrite the solution as

$$y(t) = \underbrace{CA^{-1}e^{At}B}_{\text{transient}} + \underbrace{D - CA^{-1}B}_{\text{steady-state}}, \quad t > 0. \quad (6.22)$$

The first term is the transient response and decays to zero as  $t \rightarrow \infty$ . The second term is the steady-state response and represents the value of the output for large time.

A sample step response is shown in Figure 6.9. Several key properties are used when describing a step response. The *steady-state value*  $y_{ss}$  of a step response is the final level of the output, assuming it converges. The *rise time*  $T_r$  is the amount of time required for the signal to first go from 10% of its final value to 90% of its final value. It is possible to define other limits as well, but in this book we shall use these percentages unless otherwise indicated. The *overshoot*  $M_p$  is the percentage of the final value by which the signal initially rises above the final value. This usually assumes that future values of the signal do not overshoot the final value by more than this initial transient, otherwise the term can be ambiguous. Finally, the *settling time*  $T_s$  is the amount of time required for the signal to stay within 2% of its final value for all future times. The settling time is also sometimes defined as reaching 1% or 5% of the final value (see Exercise 6.7). In general these performance measures can depend on the amplitude of the input step, but for linear systems the last three quantities defined above are independent of the size of the step.

### Example 6.7 Compartment model

Consider the compartment model illustrated in Figure 6.10 and described in more detail in Section ?? . Assume that a drug is administered by constant infusion in compartment  $V_1$  and that the drug has its effect in compartment  $V_2$ . To assess how quickly the concentration in the compartment reaches steady state we compute the step response, which is shown in Figure 6.10b. The step response is quite slow, with a settling time of 39 min. It is possible to obtain the steady-state concentration much faster by having a faster injection rate initially, as shown in Figure 6.10c.

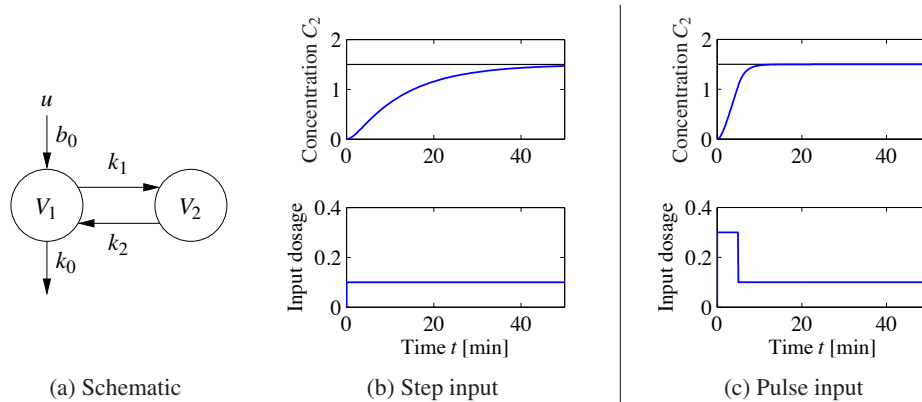

**Figure 6.10:** Response of a compartment model to a constant drug infusion. A simple diagram of the system is shown in (a). The step response (b) shows the rate of concentration buildup in compartment 2. In (c) a pulse of initial concentration is used to speed up the response.

The response of the system in this case can be computed by combining two step responses (Exercise 6.3).  $\nabla$

Another common input signal to a linear system is a sinusoid (or a combination of sinusoids). The *frequency response* of an input/output system measures the way in which the system responds to a sinusoidal excitation on one of its inputs. As we have already seen for scalar systems, the particular solution associated with a sinusoidal excitation is itself a sinusoid at the same frequency. Hence we can compare the magnitude and phase of the output sinusoid to the input.

To see this in more detail, we must evaluate the convolution equation (6.15) for  $u = \cos \omega t$ . This turns out to be a very messy calculation, but we can make use of the fact that the system is linear to simplify the derivation. In particular, we note that

$$\cos \omega t = \frac{1}{2} \left( e^{i\omega t} + e^{-i\omega t} \right).$$

Since the system is linear, it suffices to compute the response of the system to the complex input  $u(t) = e^{st}$  and we can then reconstruct the input to a sinusoid by averaging the responses corresponding to  $s = i\omega$  and  $s = -i\omega$ .

Applying the convolution equation to the input  $u = e^{st}$  we have

$$\begin{aligned} y(t) &= Ce^{At}x(0) + \int_0^t Ce^{A(t-\tau)}Be^{s\tau}d\tau + De^{st} \\ &= Ce^{At}x(0) + Ce^{At} \int_0^t e^{(sI-A)\tau}Bd\tau + De^{st}. \end{aligned}$$

If we assume that none of the eigenvalues of  $A$  are equal to  $s = \pm i\omega$ , then the



matrix  $sI - A$  is invertible, and we can write

$$\begin{aligned} y(t) &= Ce^{At}x(0) + Ce^{At} \left( (sI - A)^{-1} e^{(sI - A)\tau} B \right) \Big|_0^t + De^{st} \\ &= Ce^{At}x(0) + Ce^{At}(sI - A)^{-1} \left( e^{(sI - A)t} - I \right) B + De^{st} \\ &= Ce^{At}x(0) + C(sI - A)^{-1} e^{st} B - Ce^{At}(sI - A)^{-1} B + De^{st}, \end{aligned}$$

and we obtain

$$y(t) = \underbrace{Ce^{At} \left( x(0) - (sI - A)^{-1} B \right)}_{\text{transient}} + \underbrace{\left( C(sI - A)^{-1} B + D \right) e^{st}}_{\text{steady-state}}. \quad (6.23)$$

Notice that once again the solution consists of both a transient component and a steady-state component. The transient component decays to zero if the system is asymptotically stable and the steady-state component is proportional to the (complex) input  $u = e^{st}$ .

We can simplify the form of the solution slightly further by rewriting the steady-state response as

$$y_{\text{ss}}(t) = Me^{i\theta} e^{st} = Me^{(st + i\theta)},$$

where

$$Me^{i\theta} = C(sI - A)^{-1} B + D \quad (6.24)$$

and  $M$  and  $\theta$  represent the magnitude and phase of the complex number  $C(sI - A)^{-1} B + D$ . When  $s = i\omega$ , we say that  $M$  is the *gain* and  $\theta$  is the *phase* of the system at a given forcing frequency  $\omega$ . Using linearity and combining the solutions for  $s = +i\omega$  and  $s = -i\omega$ , we can show that if we have an input  $u = A_u \sin(\omega t + \psi)$  and an output  $y = A_y \sin(\omega t + \phi)$ , then

$$\text{gain}(\omega) = \frac{A_y}{A_u} = M, \quad \text{phase}(\omega) = \phi - \psi = \theta.$$

The steady-state solution for a sinusoid  $u = \cos \omega t = \sin(\omega t + \pi/2)$  is now given by

$$y_{\text{ss}}(t) = M \cos(\omega t + \theta).$$

If the phase  $\theta$  is positive, we say that the output *leads* the input, otherwise we say it *lags* the input.

A sample steady-state sinusoidal response is illustrated in Figure 6.11a. The dashed line shows the input sinusoid, which has amplitude 1. The output sinusoid is shown as a solid line and has a different amplitude plus a shifted phase. The gain is the ratio of the amplitudes of the sinusoids, which can be determined by measuring the height of the peaks. The phase is determined by comparing the ratio of the time between zero crossings of the input and output to the overall period of the sinusoid:

$$\theta = -2\pi \cdot \frac{\Delta T}{T}.$$

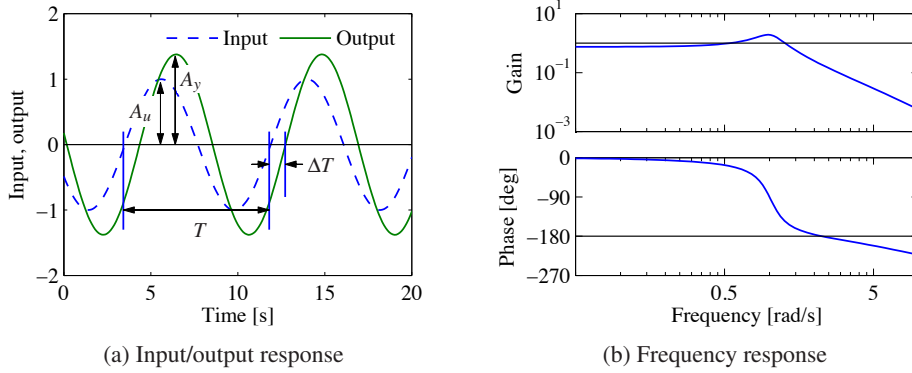

**Figure 6.11:** Steady-state response of an asymptotically stable linear system to a sinusoid. (a) A sinusoidal input of magnitude  $A_u$  (dashed) gives a sinusoidal output of magnitude  $A_y$  (solid), delayed by  $\Delta T$  seconds. (b) Frequency response, showing gain and phase. The gain is given by the ratio of the output amplitude to the input amplitude,  $M = A_y/A_u$ . The phase lag is given by  $\theta = -2\pi\Delta T/T$ ; it is negative for the case shown because the output lags the input.

A convenient way to view the frequency response is to plot how the gain and phase in equation (6.24) depend on  $\omega$  (through  $s = i\omega$ ). Figure 6.11b shows an example of this type of representation.

### Example 6.8 Active band-pass filter

Consider the op amp circuit shown in Figure 6.12a. We can derive the dynamics of the system by writing the *nodal equations*, which state that the sum of the currents at any node must be zero. Assuming that  $v_- = v_+ = 0$ , as we did in Section 4.3, we have

$$0 = \frac{v_1 - v_2}{R_1} - C_1 \frac{dv_2}{dt}, \quad 0 = C_1 \frac{dv_2}{dt} + \frac{v_3}{R_2} + C_2 \frac{dv_3}{dt}.$$

Choosing  $v_2$  and  $v_3$  as our states and using these equations, we obtain

$$\frac{dv_2}{dt} = \frac{v_1 - v_2}{R_1 C_1}, \quad \frac{dv_3}{dt} = \frac{-v_3}{R_2 C_2} - \frac{v_1 - v_2}{R_1 C_2}.$$

Rewriting these in linear state space form, we obtain

$$\frac{dx}{dt} = \begin{bmatrix} -\frac{1}{R_1 C_1} & 0 \\ \frac{1}{R_1 C_2} & -\frac{1}{R_2 C_2} \end{bmatrix} x + \begin{bmatrix} \frac{1}{R_1 C_1} \\ -\frac{1}{R_1 C_2} \end{bmatrix} u, \quad y = \begin{bmatrix} 0 & 1 \end{bmatrix} x, \quad (6.25)$$

where  $x = (v_2, v_3)$ ,  $u = v_1$  and  $y = v_3$ .

The frequency response for the system can be computed using equation (6.24):

$$Me^{j\theta} = C(sI - A)^{-1}B + D = -\frac{R_2}{R_1} \frac{R_1 C_1 s}{(1 + R_1 C_1 s)(1 + R_2 C_2 s)}, \quad s = i\omega.$$

The magnitude and phase are plotted in Figure 6.12b for  $R_1 = 100 \Omega$ ,  $R_2 = 5 \text{ k}\Omega$

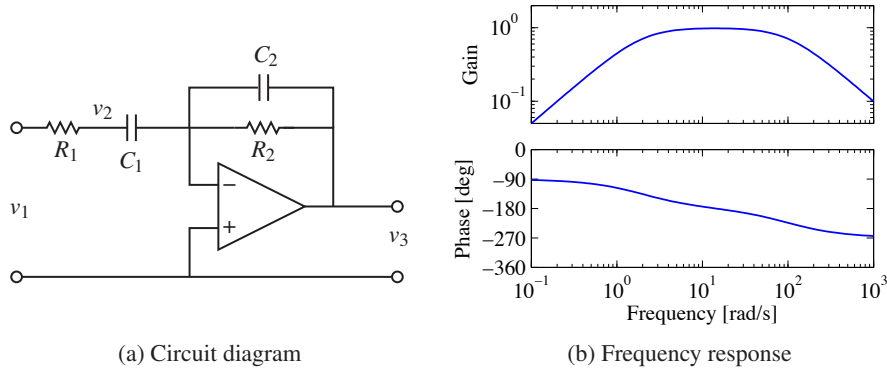

**Figure 6.12:** Active band-pass filter. The circuit diagram (a) shows an op amp with two  $RC$  filters arranged to provide a band-pass filter. The plot in (b) shows the gain and phase of the filter as a function of frequency. Note that the phase starts at  $-90^\circ$  due to the negative gain of the operational amplifier.

and  $C_1 = C_2 = 100 \mu\text{F}$ . We see that the circuit passes through signals with frequencies at about 10 rad/s, but attenuates frequencies below 5 rad/s and above 50 rad/s. At 0.1 rad/s the input signal is attenuated by  $20 \times (0.05)$ . This type of circuit is called a *band-pass filter* since it passes through signals in the band of frequencies between 5 and 50 rad/s.  $\nabla$

As in the case of the step response, a number of standard properties are defined for frequency responses. The gain of a system at  $\omega = 0$  is called the *zero frequency gain* and corresponds to the ratio between a constant input and the steady output:

$$M_0 = -CA^{-1}B + D$$

(compare to equation (6.20)). The zero frequency gain is well defined only if  $A$  is invertible (i.e., if it does not have eigenvalues at 0). It is also important to note that the zero frequency gain is a relevant quantity only when a system is stable about the corresponding equilibrium point. So, if we apply a constant input  $u = r$ , then the corresponding equilibrium point  $x_e = -A^{-1}Br$  must be stable in order to talk about the zero frequency gain. (In electrical engineering, the zero frequency gain is often called the *DC gain*. DC stands for direct current and reflects the common separation of signals in electrical engineering into a direct current (zero frequency) term and an alternating current (AC) term.)

The *bandwidth*  $\omega_b$  of a system is the frequency range over which the gain has decreased by no more than a factor of  $1/\sqrt{2}$  from its reference value. For systems with nonzero, finite zero frequency gain, the reference value is taken as the zero frequency gain. For systems that attenuate low frequencies but pass through high frequencies, the reference gain is taken as the high-frequency gain. For a system such as the band-pass filter in Example 6.8, bandwidth is defined as the range of frequencies where the gain is larger than  $1/\sqrt{2}$  of the gain at the center of the band. (For Example 6.8 this would give a bandwidth of approximately 50 rad/s.)

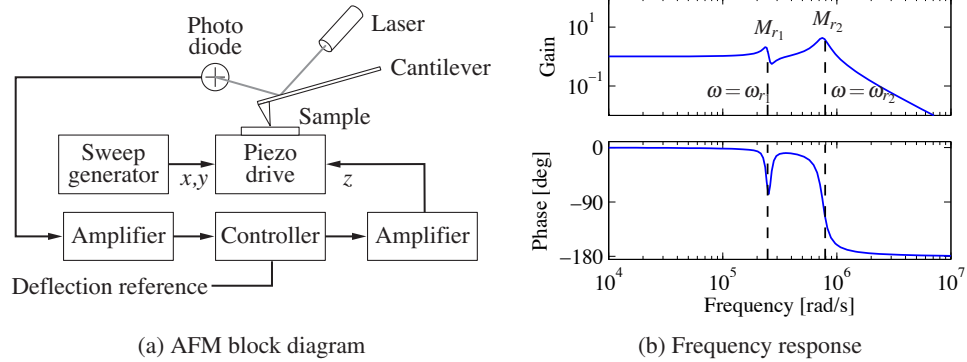

**Figure 6.13:** AFM frequency response. (a) A block diagram for the vertical dynamics of an atomic force microscope in contact mode. The plot in (b) shows the gain and phase for the piezo stack. The response contains two frequency peaks at resonances of the system, along with an antiresonance at  $\omega = 268$  krad/s. The combination of a resonant peak followed by an antiresonance is common for systems with multiple lightly damped modes.

Other important properties of the frequency response are the *resonant peak*  $M_r$ , the largest value of the frequency response, and the *peak frequency*  $\omega_{mr}$ , the frequency where the maximum occurs. These two properties describe the frequency of the sinusoidal input that produces the largest possible output and the gain at the frequency.

### Example 6.9 Atomic force microscope in contact mode

Consider the model for the vertical dynamics of the atomic force microscope in contact mode, discussed in Section 4.5. The basic dynamics are given by equation (4.23). The piezo stack can be modeled by a second-order system with undamped natural frequency  $\omega_3$  and damping ratio  $\zeta_3$ . The dynamics are then described by the linear system

$$\frac{dx}{dt} = \begin{pmatrix} 0 & 1 & 0 & 0 \\ -k_2/(m_1 + m_2) & -c_2/(m_1 + m_2) & 1/m_2 & 0 \\ 0 & 0 & 0 & \omega_3 \\ 0 & 0 & -\omega_3 & -2\zeta_3\omega_3 \end{pmatrix} x + \begin{pmatrix} 0 \\ 0 \\ 0 \\ \omega_3 \end{pmatrix} u,$$

$$y = \frac{m_2}{m_1 + m_2} \begin{pmatrix} m_1 k_2 & m_1 c_2 & 1 & 0 \end{pmatrix} x,$$

where the input signal is the drive signal to the amplifier and the output is the elongation of the piezo. The frequency response of the system is shown in Figure 6.13b. The zero frequency gain of the system is  $M_0 = 1$ . There are two resonant poles with peaks  $M_{r1} = 2.12$  at  $\omega_{mr1} = 238$  krad/s and  $M_{r2} = 4.29$  at  $\omega_{mr2} = 746$  krad/s. The bandwidth of the system, defined as the lowest frequency where the gain is  $\sqrt{2}$  less than the zero frequency gain, is  $\omega_b = 292$  krad/s. There is also a dip in the gain  $M_d = 0.556$  for  $\omega_{md} = 268$  krad/s. This dip, called an *antiresonance*, is associated with a dip in the phase and limits the performance when the system is controlled by simple controllers, as we will see in Chapter 11.  $\nabla$

### Sampling

It is often convenient to use both differential and difference equations in modeling and control. For linear systems it is straightforward to transform from one to the other. Consider the general linear system described by equation (6.13) and assume that the control signal is constant over a sampling interval of constant length  $h$ . It follows from equation (6.14) of Theorem 6.4 that

$$x(t+h) = e^{Ah}x(t) + \int_t^{t+h} e^{A(t+h-\tau)}Bu(\tau)d\tau = \Phi x(t) + \Gamma u(t), \quad (6.26)$$

where we have assumed that the discontinuous control signal is continuous from the right. The behavior of the system at the sampling times  $t = kh$  is described by the difference equation

$$x[k+1] = \Phi x[k] + \Gamma u[k], \quad y[k] = Cx[k] + Du[k], \quad (6.27)$$

where

$$\Phi = e^{Ah}, \quad \Gamma = \left( \int_0^h e^{As} ds \right) B.$$

Notice that the difference equation (6.27) is an exact representation of the behavior of the system at the sampling instants. Similar expressions can also be obtained if the control signal is linear over the sampling interval.

The transformation from (6.26) to (6.27) is called *sampling*. The relations between the system matrices in the continuous and sampled representations are as follows:

$$A = \frac{1}{h} \log \Phi, \quad B = \left( \int_0^h e^{As} ds \right)^{-1} \Gamma. \quad (6.28)$$

Notice that if  $A$  is invertible, we have

$$\Gamma = A^{-1}(e^{Ah} - I)B.$$

All continuous-time systems can be sampled to obtain a discrete-time version, but there are discrete-time systems that do not have a continuous-time equivalent. The precise condition is that the matrix  $\Phi$  cannot have real eigenvalues on the negative real axis.

#### Example 6.10 IBM Lotus server

In Example 3.4 we described how the dynamics of an IBM Lotus server were obtained as the discrete-time system

$$y[k+1] = ay[k] + bu[k],$$

where  $a = 0.43$ ,  $b = 0.47$  and the sampling period is  $h = 60$  s. A differential equation model is needed if we would like to design control systems based on continuous-time theory. Such a model is obtained by applying equation (6.28); hence

$$A = \frac{\log a}{h} = -0.0141, \quad B = \left( \int_0^h e^{At} dt \right)^{-1} b = 0.0116,$$

and we find that the difference equation can be interpreted as a sampled version of the ordinary differential equation

$$\frac{dx}{dt} = -0.0141x + 0.0116u.$$

▽

## 6.4 Linearization

As described at the beginning of the chapter, a common source of linear system models is through the approximation of a nonlinear system by a linear one. These approximations are aimed at studying the local behavior of a system, where the nonlinear effects are expected to be small. In this section we discuss how to locally approximate or convert a nonlinear system to a linear one, and what can be said about the stability of the original system in each case. We begin with an illustration of the basic concept using the cruise control example, which is described in more detail in Chapter 4.

### Example 6.11 Cruise control

The dynamics for the cruise control system are derived in Section 4.1 and have the form

$$m \frac{dv}{dt} = \alpha_n u T(\alpha_n v) - mg C_r \operatorname{sgn}(v) - \frac{1}{2} \rho C_d A v^2 - mg \sin \theta, \quad (6.29)$$

where the first term on the right-hand side of the equation is the force generated by the engine and the remaining three terms are the rolling friction, aerodynamic drag and gravitational disturbance force. There is an equilibrium  $(v_e, u_e)$  when the force applied by the engine balances the disturbance forces.

To explore the behavior of the system near the equilibrium we will linearize the system. A Taylor series expansion of equation (6.29) around the equilibrium gives

$$\frac{d(v - v_e)}{dt} = a(v_e - v) - b_g(\theta - \theta_e) + b(u - u_e) + \text{higher order terms}, \quad (6.30)$$

where

$$a = -\frac{u_e \alpha_n^2 T'(\alpha_n v_e) + \rho C_d A v_e}{m}, \quad b_g = g \cos \theta_e, \quad b = \frac{\alpha_n T(\alpha_n v_e)}{m}. \quad (6.31)$$

Notice that the term corresponding to rolling friction disappears if  $v = 0$ . For a car in fourth gear with  $v_e = 20$  m/s,  $\theta_e = 0$  and the numerical values for the car from Section 4.1, the equilibrium value for the throttle is  $u_e = 0.1687$  and the parameters are  $a = 0.0101$ ,  $b = 1.32$  and  $b_g = 9.8$ . This linear model describes how small perturbations in the velocity about the nominal speed evolve in time.

Figure 6.14 shows a simulation of a cruise controller with linear and nonlinear models; the differences between the linear and nonlinear models are small, and hence the linearized model provides a reasonable approximation. ▽

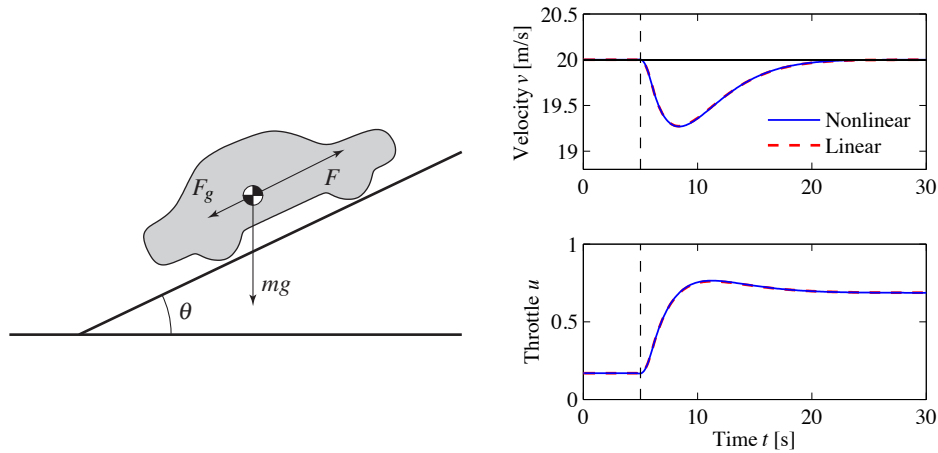

**Figure 6.14:** Simulated response of a vehicle with PI cruise control as it climbs a hill with a slope of  $4^\circ$ . The solid line is the simulation based on a nonlinear model, and the dashed line shows the corresponding simulation using a linear model. The controller gains are  $k_p = 0.5$  and  $k_i = 0.1$ .

### Jacobian Linearization Around an Equilibrium Point

To proceed more formally, consider a single-input, single-output nonlinear system

$$\begin{aligned} \frac{dx}{dt} &= f(x, u), & x \in \mathbb{R}^n, u \in \mathbb{R}, \\ y &= h(x, u), & y \in \mathbb{R}, \end{aligned} \quad (6.32)$$

with an equilibrium point at  $x = x_e$ ,  $u = u_e$ . Without loss of generality we can assume that  $x_e = 0$  and  $u_e = 0$ , although initially we will consider the general case to make the shift of coordinates explicit.

To study the *local* behavior of the system around the equilibrium point  $(x_e, u_e)$ , we suppose that  $x - x_e$  and  $u - u_e$  are both small, so that nonlinear perturbations around this equilibrium point can be ignored compared with the (lower-order) linear terms. This is roughly the same type of argument that is used when we do small-angle approximations, replacing  $\sin \theta$  with  $\theta$  and  $\cos \theta$  with 1 for  $\theta$  near zero.

As we did in Chapter 5, we define a new set of state variables  $z$ , as well as inputs  $v$  and outputs  $w$ :

$$z = x - x_e, \quad v = u - u_e, \quad w = y - h(x_e, u_e).$$

These variables are all close to zero when we are near the equilibrium point, and so in these variables the nonlinear terms can be thought of as the higher-order terms in a Taylor series expansion of the relevant vector fields (assuming for now that these exist).

Formally, the *Jacobian linearization* of the nonlinear system (6.32) is

$$\frac{dz}{dt} = Az + Bv, \quad w = Cz + Dv, \quad (6.33)$$

where

$$A = \left. \frac{\partial f}{\partial x} \right|_{(x_e, u_e)}, \quad B = \left. \frac{\partial f}{\partial u} \right|_{(x_e, u_e)}, \quad C = \left. \frac{\partial h}{\partial x} \right|_{(x_e, u_e)}, \quad D = \left. \frac{\partial h}{\partial u} \right|_{(x_e, u_e)}. \quad (6.34)$$

The system (6.33) approximates the original system (6.32) when we are near the equilibrium point about which the system was linearized. It follows from Theorem 5.3 that if the linearization is asymptotically stable, then the equilibrium point  $x_e$  is locally asymptotically stable for the full nonlinear system.

It is important to note that we can define the linearization of a system only near an equilibrium point. To see this, consider a polynomial system

$$\frac{dx}{dt} = a_0 + a_1x + a_2x^2 + a_3x^3 + u,$$

where  $a_0 \neq 0$ . A set of equilibrium points for this system is given by  $(x_e, u_e) = (x_e, -a_0 - a_1x_e - a_2x_e^2 - a_3x_e^3)$ , and we can linearize around any of them. Suppose that we try to linearize around the origin of the system  $x = 0, u = 0$ . If we drop the higher-order terms in  $x$ , then we get

$$\frac{dx}{dt} = a_0 + a_1x + u,$$

which is *not* the Jacobian linearization if  $a_0 \neq 0$ . The constant term must be kept, and it is not present in (6.33). Furthermore, even if we kept the constant term in the approximate model, the system would quickly move away from this point (since it is “driven” by the constant term  $a_0$ ), and hence the approximation could soon fail to hold.

Software for modeling and simulation frequently has facilities for performing linearization symbolically or numerically. The MATLAB command `trim` finds the equilibrium, and `linmod` extracts linear state space models from a SIMULINK system around an operating point.

### Example 6.12 Vehicle steering

Consider the vehicle steering system introduced in Example 3.10. The nonlinear equations of motion for the system are given by equations (3.26)–(3.28) and can be written as

$$\frac{d}{dt} \begin{pmatrix} x \\ y \\ \theta \end{pmatrix} = \begin{pmatrix} v \cos(\alpha(\delta) + \theta) \\ v \sin(\alpha(\delta) + \theta) \\ \frac{v_0}{b} \tan \delta \end{pmatrix}, \quad \alpha(\delta) = \arctan\left(\frac{a \tan \delta}{b}\right),$$

where  $x, y$  and  $\theta$  are the position and orientation of the center of mass of the vehicle,  $v_0$  is the velocity of the rear wheel,  $b$  is the distance between the front and rear wheels,  $\delta$  is the angle of the front wheel and  $v$  is the velocity of the center of



mass. The function  $\alpha(\delta)$  is the angle between the velocity vector and the vehicle's length axis.

We are interested in the motion of the vehicle about a straight-line path ( $\theta = \theta_0$ ) with fixed velocity  $v_0 \neq 0$ . To find the relevant equilibrium point, we first set  $\dot{\theta} = 0$  and we see that we must have  $\delta = 0$ , corresponding to the steering wheel being straight. This also yields  $\alpha = 0$ . Looking at the first two equations in the dynamics, we see that the motion in the  $xy$  direction is by definition *not* at equilibrium since  $\dot{x}^2 + \dot{y}^2 = v^2 \neq 0$ . Therefore we cannot formally linearize the full model.

Suppose instead that we are concerned with the lateral deviation of the vehicle from a straight line. For simplicity, we let  $\theta_e = 0$ , which corresponds to driving along the  $x$  axis. We can then focus on the equations of motion in the  $y$  and  $\theta$  directions. With some abuse of notation we introduce the state  $x = (y, \theta)$  and  $u = \delta$ . The system is then in standard form with

$$f(x, u) = \begin{pmatrix} v \sin(\alpha(u) + x_2) \\ \frac{v_0}{b} \tan u \end{pmatrix}, \quad \alpha(u) = \arctan\left(\frac{a \tan u}{b}\right), \quad h(x, u) = x_1.$$

The equilibrium point of interest is given by  $x = (0, 0)$  and  $u = 0$ . To compute the linearized model around this equilibrium point, we make use of the formulas (6.34). A straightforward calculation yields

$$\begin{aligned} A &= \left. \frac{\partial f}{\partial x} \right|_{\substack{x=0 \\ u=0}} = \begin{pmatrix} 0 & v_0 \\ 0 & 0 \end{pmatrix}, & B &= \left. \frac{\partial f}{\partial u} \right|_{\substack{x=0 \\ u=0}} = \begin{pmatrix} av_0/b \\ v_0/b \end{pmatrix}, \\ C &= \left. \frac{\partial h}{\partial x} \right|_{\substack{x=0 \\ u=0}} = \begin{pmatrix} 1 & 0 \end{pmatrix}, & D &= \left. \frac{\partial h}{\partial u} \right|_{\substack{x=0 \\ u=0}} = 0, \end{aligned}$$

and the linearized system

$$\frac{dx}{dt} = Ax + Bu, \quad y = Cx + Du \quad (6.35)$$

thus provides an approximation to the original nonlinear dynamics.

The linearized model can be simplified further by introducing normalized variables, as discussed in Section 3.3. For this system, we choose the wheel base  $b$  as the length unit and the time unit as the time required to travel a wheel base. The normalized state is thus  $z = (x_1/b, x_2)$ , and the new time variable is  $\tau = v_0 t/b$ . The model (6.35) then becomes

$$\frac{dz}{d\tau} = \begin{pmatrix} z_2 + \gamma u \\ u \end{pmatrix} = \begin{pmatrix} 0 & 1 \\ 0 & 0 \end{pmatrix} z + \begin{pmatrix} \gamma \\ 1 \end{pmatrix} u, \quad y = \begin{pmatrix} 1 & 0 \end{pmatrix} z, \quad (6.36)$$

where  $\gamma = a/b$ . The normalized linear model for vehicle steering with nonslipping wheels is thus a linear system with only one parameter.  $\nabla$

### Feedback Linearization

Another type of linearization is the use of feedback to convert the dynamics of a nonlinear system into those of a linear one. We illustrate the basic idea with an example.

#### Example 6.13 Cruise control

Consider again the cruise control system from Example 6.11, whose dynamics are given in equation (6.29):

$$m \frac{dv}{dt} = \alpha_n u T(\alpha_n v) - mg C_r \operatorname{sgn}(v) - \frac{1}{2} \rho C_d A v^2 - mg \sin \theta.$$

If we choose  $u$  as a feedback law of the form

$$u = \frac{1}{\alpha_n T(\alpha_n v)} \left( u' + mg C_r \operatorname{sgn}(v) + \frac{1}{2} \rho C_d A v^2 \right), \quad (6.37)$$

then the resulting dynamics become

$$m \frac{dv}{dt} = u' + d, \quad (6.38)$$

where  $d(t) = -mg \sin \theta(t)$  is the disturbance force due the slope of the road (which may be changing as we drive). If we now define a feedback law for  $u'$  (such as a proportional-integral-derivative [PID] controller), we can use equation (6.37) to compute the final input that should be commanded.

Equation (6.38) is a linear differential equation. We have essentially “inverted” the nonlinearity through the use of the feedback law (6.37). This requires that we have an accurate measurement of the vehicle velocity  $v$  as well as an accurate model of the torque characteristics of the engine, gear ratios, drag and friction characteristics and mass of the car. While such a model is not generally available (remembering that the parameter values can change), if we design a good feedback law for  $u'$ , then we can achieve robustness to these uncertainties.  $\nabla$

More generally, we say that a system of the form

$$\frac{dx}{dt} = f(x, u), \quad y = h(x),$$

is *feedback linearizable* if there exists a control law  $u = \alpha(x, v)$  such that the resulting closed loop system is input/output linear with input  $v$  and output  $y$ , as shown in Figure 6.15. To fully characterize such systems is beyond the scope of this text, but we note that in addition to changes in the input, the general theory also allows for (nonlinear) changes in the states that are used to describe the system, keeping only the input and output variables fixed. More details of this process can be found in the textbooks by Isidori [Isi95] and Khalil [Kha01].



One case that comes up relatively frequently, and is hence worth special mention, is the set of mechanical systems of the form

$$M(q)\ddot{q} + C(q, \dot{q}) = B(q)u.$$

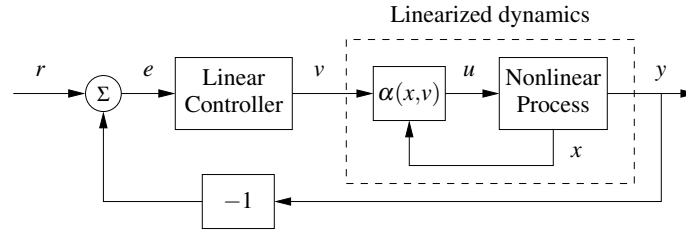

**Figure 6.15:** Feedback linearization. A nonlinear feedback of the form  $u = \alpha(x, v)$  is used to modify the dynamics of a nonlinear process so that the response from the input  $v$  to the output  $y$  is linear. A linear controller can then be used to regulate the system's dynamics.

Here  $q \in \mathbb{R}^n$  is the configuration of the mechanical system,  $M(q) \in \mathbb{R}^{n \times n}$  is the configuration-dependent inertia matrix,  $C(q, \dot{q}) \in \mathbb{R}^n$  represents the Coriolis forces and additional nonlinear forces (such as stiffness and friction) and  $B(q) \in \mathbb{R}^{n \times p}$  is the input matrix. If  $p = n$ , then we have the same number of inputs and configuration variables, and if we further have that  $B(q)$  is an invertible matrix for all configurations  $q$ , then we can choose

$$u = B^{-1}(q)(M(q)v + C(q, \dot{q})). \quad (6.39)$$

The resulting dynamics become

$$M(q)\ddot{q} = M(q)v \quad \implies \quad \ddot{q} = v,$$

which is a linear system. We can now use the tools of linear system theory to analyze and design control laws for the linearized system, remembering to apply equation (6.39) to obtain the actual input that will be applied to the system.

This type of control is common in robotics, where it goes by the name of *computed torque*, and in aircraft flight control, where it is called *dynamic inversion*. Some modeling tools like Modelica can generate the code for the inverse model automatically. One caution is that feedback linearization can often cancel out beneficial terms in the natural dynamics, and hence it must be used with care. Extensions that do not require complete cancellation of nonlinearities are discussed in Khalil [Kha01] and Krstić et al. [KKK95].

## 6.5 Further Reading

The majority of the material in this chapter is classical and can be found in most books on dynamics and control theory, including early works on control such as James, Nichols and Phillips [JNP47] and more recent textbooks such as Dorf and Bishop [DB04], Franklin, Powell and Emami-Naeini [FPEN05] and Ogata [Oga01]. An excellent presentation of linear systems based on the matrix exponential is given in the book by Brockett [Bro70], a more comprehensive treatment is given by Rugh [Rug95] and an elegant mathematical treatment is given in Sontag [Son98]. Material on feedback linearization can be found in books on nonlinear control theory such as Isidori [Isi95] and Khalil [Kha01]. The idea of characterizing dynamics

by considering the responses to step inputs is due to Heaviside, he also introduced an operator calculus to analyze linear systems. The unit step is therefore also called the *Heaviside step function*. Analysis of linear systems was simplified significantly, but Heaviside's work was heavily criticized because of lack of mathematical rigor, as described in the biography by Nahin [Nah88]. The difficulties were cleared up later by the mathematician Laurent Schwartz who developed *distribution theory* in the late 1940s. In engineering, linear systems have traditionally been analyzed using Laplace transforms as described in Gardner and Barnes [GB42]. Use of the matrix exponential started with developments of control theory in the 1960s, strongly stimulated by a textbook by Zadeh and Desoer [ZD63]. Use of matrix techniques expanded rapidly when the powerful methods of numeric linear algebra were packaged in programs like LabVIEW, MATLAB and Mathematica.

### Exercises

**6.1** (Response to the derivative of a signal) Show that if  $y(t)$  is the output of a linear system corresponding to input  $u(t)$ , then the output corresponding to an input  $\dot{u}(t)$  is given by  $\dot{y}(t)$ . (Hint: Use the definition of the derivative:  $\dot{y}(t) = \lim_{\varepsilon \rightarrow 0} (y(t + \varepsilon) - y(t)) / \varepsilon$ .)



**6.2** (Impulse response and convolution) Show that a signal  $u(t)$  can be decomposed in terms of the impulse function  $\delta(t)$  as

$$u(t) = \int_0^t \delta(t - \tau) u(\tau) d\tau$$

and use this decomposition plus the principle of superposition to show that the response of a linear system to an input  $u(t)$  (assuming a zero initial condition) can be written as

$$y(t) = \int_0^t h(t - \tau) u(\tau) d\tau,$$

where  $h(t)$  is the impulse response of the system.

**6.3** (Pulse response for a compartment model) Consider the compartment model given in Example 6.7. Compute the step response for the system and compare it with Figure 6.10b. Use the principle of superposition to compute the response to the 5 s pulse input shown in Figure 6.10c. Use the parameter values  $k_0 = 0.1$ ,  $k_1 = 0.1$ ,  $k_2 = 0.5$  and  $b_0 = 1.5$ .

**6.4** (Matrix exponential for second-order system) Assume that  $\zeta > 1$  and let  $\omega_d = \omega_0 \sqrt{\zeta^2 - 1}$ . Show that

$$\exp \begin{pmatrix} -\zeta \omega_0 & \omega_d \\ \omega_d & -\zeta \omega_0 \end{pmatrix} t = e^{-\zeta \omega_0 t} \begin{pmatrix} \cos \omega_d t & \sin \omega_d t \\ \sin \omega_d t & \cos \omega_d t \end{pmatrix}.$$

Also show that

$$\exp \begin{pmatrix} -\omega_0 & \omega_0 \\ 0 & -\omega_0 \end{pmatrix} t = e^{-\omega_0 t} \begin{pmatrix} 1 & \omega_0 t \\ 0 & 1 \end{pmatrix}.$$

**6.5** (Lyapunov function for a linear system) Consider a linear system  $\dot{x} = Ax$  with  $\operatorname{Re} \lambda_j < 0$  for all eigenvalues  $\lambda_j$  of the matrix  $A$ . Show that the matrix

$$P = \int_0^{\infty} e^{A^T \tau} Q e^{A \tau} d\tau$$

defines a Lyapunov function of the form  $V(x) = x^T P x$ .

**6.6** (Nondiagonal Jordan form) Consider a linear system with a Jordan form that is non-diagonal.

(a) Prove Proposition 6.3 by showing that if the system contains a real eigenvalue  $\lambda = 0$  with a nontrivial Jordan block, then there exists an initial condition with a solution that grows in time.

(b) Extend this argument to the case of complex eigenvalues with  $\operatorname{Re} \lambda = 0$  by using the block Jordan form 

$$J_i = \begin{pmatrix} 0 & \omega & 1 & 0 \\ -\omega & 0 & 0 & 1 \\ 0 & 0 & 0 & \omega \\ 0 & 0 & -\omega & 0 \end{pmatrix}.$$

**6.7** (Rise time for a first-order system) Consider a first-order system of the form

$$\tau \frac{dx}{dt} = -x + u, \quad y = x.$$

We say that the parameter  $\tau$  is the *time constant* for the system since the zero input system approaches the origin as  $e^{-t/\tau}$ . For a first-order system of this form, show that the rise time for a step response of the system is approximately  $2\tau$ , and that 1%, 2%, and 5% settling times approximately corresponds to  $4.6\tau$ ,  $4\tau$  and  $3\tau$ .

**6.8** (Discrete-time systems) Consider a linear discrete-time system of the form

$$x[k+1] = Ax[k] + Bu[k], \quad y[k] = Cx[k] + Du[k].$$

(a) Show that the general form of the output of a discrete-time linear system is given by the discrete-time convolution equation:

$$y[k] = CA^k x[0] + \sum_{j=0}^{k-1} CA^{k-j-1} Bu[j] + Du[k].$$

(b) Show that a discrete-time linear system is asymptotically stable if and only if all the eigenvalues of  $A$  have a magnitude strictly less than 1.

**6.9** (Keynesian economics) Consider the following simple Keynesian macroeconomic model in the form of a linear discrete-time system discussed in Exercise 6.8:

$$\begin{pmatrix} C[t+1] \\ I[t+1] \end{pmatrix} = \begin{pmatrix} a & a \\ ab-b & ab \end{pmatrix} \begin{pmatrix} C[t] \\ I[t] \end{pmatrix} + \begin{pmatrix} a \\ ab \end{pmatrix} G[t],$$

$$Y[t] = C[t] + I[t] + G[t].$$

Determine the eigenvalues of the dynamics matrix. When are the magnitudes of the eigenvalues less than 1? Assume that the system is in equilibrium with constant values capital spending  $C$ , investment  $I$  and government expenditure  $G$ . Explore what happens when government expenditure increases by 10%. Use the values  $a = 0.25$  and  $b = 0.5$ .

**6.10** Consider a scalar system

$$\frac{dx}{dt} = 1 - x^3 + u.$$

Compute the equilibrium points for the unforced system ( $u = 0$ ) and use a Taylor series expansion around the equilibrium point to compute the linearization. Verify that this agrees with the linearization in equation (6.33).

**6.11** (Transcriptional regulation) Consider the dynamics of a genetic circuit that implements *self-repression*: the protein produced by a gene is a repressor for that gene, thus restricting its own production. Using the models presented in Example 3.15, the dynamics for the system can be written as

$$\frac{dm}{dt} = \frac{\alpha}{1 + kp^2} + \alpha_0 - \gamma m - u, \quad \frac{dp}{dt} = \beta m - \delta p, \quad (6.40)$$

where  $u$  is a disturbance term that affects RNA transcription and  $m, p \geq 0$ . Find the equilibrium points for the system and use the linearized dynamics around each equilibrium point to determine the local stability of the equilibrium point and the step response of the system to a disturbance.

---

## Chapter Seven

### State Feedback

*Intuitively, the state may be regarded as a kind of information storage or memory or accumulation of past causes. We must, of course, demand that the set of internal states  $\Sigma$  be sufficiently rich to carry all information about the past history of  $\Sigma$  to predict the effect of the past upon the future. We do not insist, however, that the state is the least such information although this is often a convenient assumption.*

R. E. Kalman, P. L. Falb and M. A. Arbib, *Topics in Mathematical System Theory*, 1969 [KFA69].

This chapter describes how the feedback of a system's state can be used to shape the local behavior of a system. The concept of reachability is introduced and used to investigate how to design the dynamics of a system through assignment of its eigenvalues. In particular, it will be shown that under certain conditions it is possible to assign the system eigenvalues arbitrarily by appropriate feedback of the system state.

#### 7.1 Reachability

One of the fundamental properties of a control system is what set of points in the state space can be reached through the choice of a control input. It turns out that the property of reachability is also fundamental in understanding the extent to which feedback can be used to design the dynamics of a system.

##### Definition of Reachability

We begin by disregarding the output measurements of the system and focusing on the evolution of the state, given by

$$\frac{dx}{dt} = Ax + Bu, \quad (7.1)$$

where  $x \in \mathbb{R}^n$ ,  $u \in \mathbb{R}$ ,  $A$  is an  $n \times n$  matrix and  $B$  a column vector. A fundamental question is whether it is possible to find control signals so that any point in the state space can be reached through some choice of input. To study this, we define the *reachable set*  $\mathcal{R}(x_0, \leq T)$  as the set of all points  $x_f$  such that there exists an input  $u(t)$ ,  $0 \leq t \leq T$  that steers the system from  $x(0) = x_0$  to  $x(T) = x_f$ , as illustrated in Figure 7.1a.

**Definition 7.1** (Reachability). A linear system is *reachable* if for any  $x_0, x_f \in \mathbb{R}^n$  there exists a  $T > 0$  and  $u: [0, T] \rightarrow \mathbb{R}$  such that if  $x(0) = x_0$  then the corresponding solution satisfies  $x(T) = x_f$ .

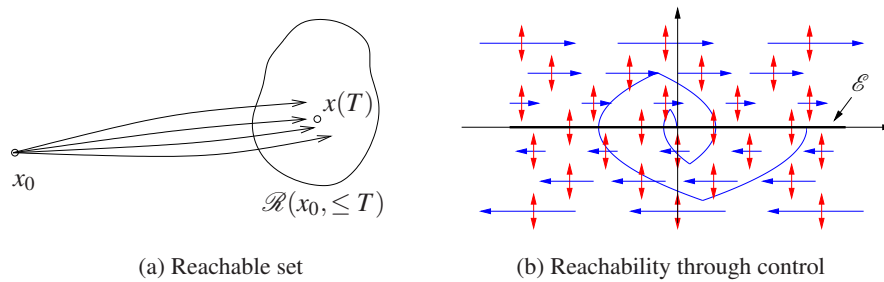

**Figure 7.1:** The reachable set for a control system. The set  $\mathcal{R}(x_0, \leq T)$  shown in (a) is the set of points reachable from  $x_0$  in time less than  $T$ . The phase portrait in (b) shows the dynamics for a double integrator, with the natural dynamics drawn as horizontal arrows and the control inputs drawn as vertical arrows. The set of achievable equilibrium points is the  $x$  axis. By setting the control inputs as a function of the state, it is possible to steer the system to the origin, as shown on the sample path.

The definition of reachability addresses whether it is possible to reach all points in the state space in a *transient* fashion. In many applications, the set of points that we are most interested in reaching is the set of equilibrium points of the system (since we can remain at those points with constant input  $u$ ). The set of all possible equilibria for constant controls is given by

$$\mathcal{E} = \{x_e : Ax_e + Bu_e = 0 \text{ for some } u_e \in \mathbb{R}\}.$$

This means that possible equilibria lie in a one- (or possibly higher) dimensional subspace. If the matrix  $A$  is invertible, this subspace is one-dimensional and is spanned by  $A^{-1}B$ .

The following example provides some insight into the possibilities.

### Example 7.1 Double integrator

Consider a linear system consisting of a double integrator whose dynamics are given by

$$\frac{dx_1}{dt} = x_2, \quad \frac{dx_2}{dt} = u.$$

Figure 7.1b shows a phase portrait of the system. The open loop dynamics ( $u = 0$ ) are shown as horizontal arrows pointed to the right for  $x_2 > 0$  and to the left for  $x_2 < 0$ . The control input is represented by a double-headed arrow in the vertical direction, corresponding to our ability to set the value of  $\dot{x}_2$ . The set of equilibrium points  $\mathcal{E}$  corresponds to the  $x_1$  axis, with  $u_e = 0$ .

Suppose first that we wish to reach the origin from an initial condition  $(a, 0)$ . We can directly move the state up and down in the phase plane, but we must rely on the natural dynamics to control the motion to the left and right. If  $a > 0$ , we can move toward the origin by first setting  $u < 0$ , which will cause  $x_2$  to become negative. Once  $x_2 < 0$ , the value of  $x_1$  will begin to decrease and we will move to the left. After a while, we can set  $u_2$  to be positive, moving  $x_2$  back toward zero



and slowing the motion in the  $x_1$  direction. If we bring  $x_2$  to a positive value, we can move the system state in the opposite direction.

Figure 7.1b shows a sample trajectory bringing the system to the origin. Note that if we steer the system to an equilibrium point, it is possible to remain there indefinitely (since  $\dot{x}_1 = 0$  when  $x_2 = 0$ ), but if we go to any other point in the state space, we can pass through the point only in a transient fashion.  $\nabla$

To find general conditions under which a linear system is reachable, we will first give a heuristic argument based on formal calculations with impulse functions. We note that if we can reach all points in the state space through some choice of input, then we can also reach all equilibrium points.

### Testing for Reachability

When the initial state is zero, the response of the system (7.1) to an input  $u(t)$  is given by

$$x(t) = \int_0^t e^{A(t-\tau)} B u(\tau) d\tau. \quad (7.2)$$

If we choose the input to be a impulse function  $\delta(t)$  as defined in Section 6.3, the state becomes

$$x_\delta = \int_0^t e^{A(t-\tau)} B \delta(\tau) d\tau = e^{At} B.$$

(Note that the state changes instantaneously in response to the impulse.) We can find the response to the derivative of an impulse function by taking the derivative of the impulse response (Exercise 6.1):

$$x_{\dot{\delta}} = \frac{dx_\delta}{dt} = A e^{At} B.$$

Continuing this process and using the linearity of the system, the input

$$u(t) = \alpha_1 \delta(t) + \alpha_2 \dot{\delta}(t) + \alpha_3 \ddot{\delta}(t) + \cdots + \alpha_n \delta^{(n-1)}(t)$$

gives the state

$$x(t) = \alpha_1 e^{At} B + \alpha_2 A e^{At} B + \alpha_3 A^2 e^{At} B + \cdots + \alpha_n A^{n-1} e^{At} B.$$

Taking the limit as  $t$  goes to zero through positive values, we get

$$\lim_{t \rightarrow 0^+} x(t) = \alpha_1 B + \alpha_2 AB + \alpha_3 A^2 B + \cdots + \alpha_n A^{n-1} B.$$

On the right is a linear combination of the columns of the matrix

$$W_r = \begin{bmatrix} B & AB & \cdots & A^{n-1}B \end{bmatrix}. \quad (7.3)$$

To reach an arbitrary point in the state space, we thus require that  $W_r$  is nonsingular (and hence invertible). The matrix  $W_r$  is called the *reachability matrix*.

Although we have only considered the scalar input case, it turns out that this same test works in the multi-input case, where we require that  $W_r$  be full rank (have  $n$  linearly independent columns). In addition, it can be shown that only the terms

up to  $A^{n-1}B$  must be computed; additional terms add no new directions to  $W_r$  (see Exercise 7.10).

An input consisting of a sum of impulse functions and their derivatives is a very violent signal. To see that an arbitrary point can be reached with smoother signals we can make use of the convolution equation. Assuming that the initial condition is zero, the state of a linear system is given by

$$x(t) = \int_0^t e^{A(t-\tau)} B u(\tau) d\tau = \int_0^t e^{A\tau} B u(t-\tau) d\tau.$$

It follows from the theory of matrix functions, specifically the Cayley–Hamilton theorem (see Exercise 7.10), that

$$e^{A\tau} = I\alpha_0(\tau) + A\alpha_1(\tau) + \cdots + A^{n-1}\alpha_{n-1}(\tau),$$

where  $\alpha_i(\tau)$  are scalar functions, and we find that

$$\begin{aligned} x(t) &= B \int_0^t \alpha_0(\tau) u(t-\tau) d\tau + AB \int_0^t \alpha_1(\tau) u(t-\tau) d\tau \\ &\quad + \cdots + A^{n-1}B \int_0^t \alpha_{n-1}(\tau) u(t-\tau) d\tau. \end{aligned}$$

Again we observe that the right-hand side is a linear combination of the columns of the reachability matrix  $W_r$  given by equation (7.3). This basic approach leads to the following theorem.

**Theorem 7.1** (Reachability rank condition). *A linear system of the form (7.1) is reachable if and only if the reachability matrix  $W_r$  is invertible (full rank).*

The formal proof of this theorem is beyond the scope of this text but follows along the lines of the sketch above and can be found in most books on linear control theory, such as Callier and Desoer [CD91] or Lewis [Lew03]. It is also interesting to note that Theorem 7.1 makes no mention of the time  $T$  that was in our definition of reachability. For a linear system, it turns out that we can find an input taking  $x_0$  to  $x_f$  for *any*  $T > 0$ , though the size of the input required can be very large when  $T$  is very small.

We illustrate the concept of reachability with the following example.

### Example 7.2 Balance system

Consider the balance system introduced in Example 3.1 and shown in Figure 7.2. Recall that this system is a model for a class of examples in which the center of mass is balanced above a pivot point. One example is the Segway Personal Transporter shown in Figure 7.2a, about which a natural question to ask is whether we can move from one stationary point to another by appropriate application of forces through the wheels.

The nonlinear equations of motion for the system are given in equation (3.9) and repeated here:

$$\begin{aligned} (M+m)\ddot{p} - ml \cos \theta \ddot{\theta} &= -c\dot{p} - ml \sin \theta \dot{\theta}^2 + F, \\ (J+ml^2)\ddot{\theta} - ml \cos \theta \ddot{p} &= -\gamma\dot{\theta} + mgl \sin \theta. \end{aligned} \tag{7.4}$$



(a) Segway

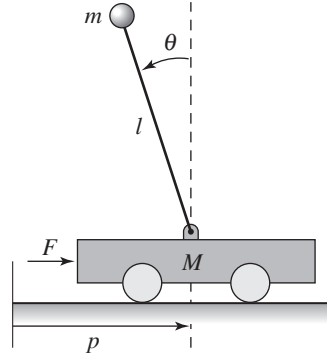

(b) Cart-pendulum system

**Figure 7.2:** Balance system. The Segway Personal Transporter shown in (a) is an example of a balance system that uses torque applied to the wheels to keep the rider upright. A simplified diagram for a balance system is shown in (b). The system consists of a mass  $m$  on a rod of length  $l$  connected by a pivot to a cart with mass  $M$ .

For simplicity, we take  $c = \gamma = 0$ . Linearizing around the equilibrium point  $x_e = (p, 0, 0, 0)$ , the dynamics matrix and the control matrix are

$$A = \begin{pmatrix} 0 & 0 & 1 & 0 \\ 0 & 0 & 0 & 1 \\ 0 & m^2 l^2 g / \mu & 0 & 0 \\ 0 & M_t m g l / \mu & 0 & 0 \end{pmatrix}, \quad B = \begin{pmatrix} 0 \\ 0 \\ J_t / \mu \\ l m / \mu \end{pmatrix},$$

where  $\mu = M_t J_t - m^2 l^2$ ,  $M_t = M + m$  and  $J_t = J + m l^2$ . The reachability matrix is

$$W_r = \begin{pmatrix} 0 & J_t / \mu & 0 & g l^3 m^3 / \mu^2 \\ 0 & l m / \mu & 0 & g l^2 m^2 (m + M) / \mu^2 \\ J_t / \mu & 0 & g l^3 m^3 / \mu^2 & 0 \\ l m / \mu & 0 & g l^2 m^2 (m + M) / \mu^2 & 0 \end{pmatrix}. \quad (7.5)$$

The determinant of this matrix is

$$\det(W_r) = \frac{g^2 l^4 m^4}{(\mu)^4} \neq 0,$$

and we can conclude that the system is reachable. This implies that we can move the system from any initial state to any final state and, in particular, that we can always find an input to bring the system from an initial state to an equilibrium point.  $\nabla$

It is useful to have an intuitive understanding of the mechanisms that make a system unreachable. An example of such a system is given in Figure 7.3. The system consists of two identical systems with the same input. We cannot separately cause the first and the second systems to do something different since they have the same input. Hence we cannot reach arbitrary states, and so the system is not

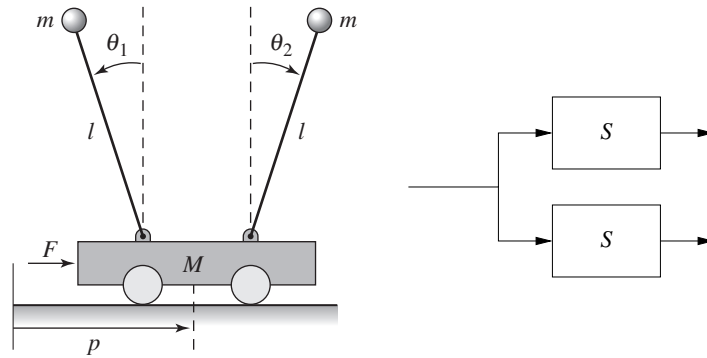

**Figure 7.3:** An unreachable system. The cart–pendulum system shown on the left has a single input that affects two pendula of equal length and mass. Since the forces affecting the two pendula are the same and their dynamics are identical, it is not possible to arbitrarily control the state of the system. The figure on the right is a block diagram representation of this situation.

reachable (Exercise ??).

More subtle mechanisms for nonreachability can also occur. For example, if there is a linear combination of states that always remains constant, then the system is not reachable. To see this, suppose that there exists a row vector  $H$  such that

$$0 = \frac{d}{dt} Hx = H(Ax + Bu), \quad \text{for all } x \text{ and } u.$$

Then  $H$  is in the left null space of both  $A$  and  $B$  and it follows that

$$HW_r = H \begin{pmatrix} B & AB & \cdots & A^{n-1}B \end{pmatrix} = 0.$$

Hence the reachability matrix is not full rank. In this case, if we have an initial condition  $x_0$  and we wish to reach a state  $x_f$  for which  $Hx_0 \neq Hx_f$ , then since  $Hx(t)$  is constant, no input  $u$  can move the state from  $x_0$  to  $x_f$ .

### Reachable Canonical Form

As we have already seen in previous chapters, it is often convenient to change coordinates and write the dynamics of the system in the transformed coordinates  $z = Tx$ . One application of a change of coordinates is to convert a system into a canonical form in which it is easy to perform certain types of analysis.

A linear state space system is in *reachable canonical form* if its dynamics are

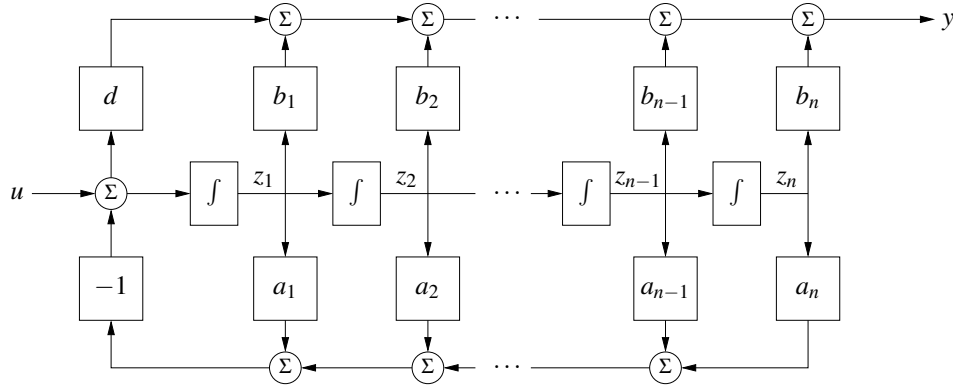

**Figure 7.4:** Block diagram for a system in reachable canonical form. The individual states of the system are represented by a chain of integrators whose input depends on the weighted values of the states. The output is given by an appropriate combination of the system input and other states.

given by

$$\frac{dz}{dt} = \begin{pmatrix} -a_1 & -a_2 & -a_3 & \dots & -a_n \\ 1 & 0 & 0 & \dots & 0 \\ 0 & 1 & 0 & \dots & 0 \\ \vdots & & \ddots & \ddots & \vdots \\ 0 & & & 1 & 0 \end{pmatrix} z + \begin{pmatrix} 1 \\ 0 \\ 0 \\ \vdots \\ 0 \end{pmatrix} u, \quad (7.6)$$

$$y = \begin{pmatrix} b_1 & b_2 & b_3 & \dots & b_n \end{pmatrix} z + du.$$

A block diagram for a system in reachable canonical form is shown in Figure 7.4. We see that the coefficients that appear in the  $A$  and  $B$  matrices show up directly in the block diagram. Furthermore, the output of the system is a simple linear combination of the outputs of the integration blocks.

The characteristic polynomial for a system in reachable canonical form is given by

$$\lambda(s) = s^n + a_1 s^{n-1} + \dots + a_{n-1} s + a_n. \quad (7.7)$$

The reachability matrix also has a relatively simple structure:

$$\tilde{W}_r = \begin{pmatrix} \tilde{B} & \tilde{A}\tilde{B} & \dots & \tilde{A}^{n-1}\tilde{B} \end{pmatrix} = \begin{pmatrix} 1 & -a_1 & a_1^2 - a_2 & \dots & * \\ 0 & 1 & -a_1 & \dots & * \\ \vdots & \vdots & \ddots & \ddots & \vdots \\ 0 & 0 & 0 & 1 & * \\ 0 & 0 & 0 & \dots & 1 \end{pmatrix},$$

where  $*$  indicates a possibly nonzero term and we use a tilde to remind us that  $A$  and  $B$  are in a special form. The matrix  $W_r$  is full rank since no column can be written as a linear combination of the others because of the triangular structure of the matrix.

We now consider the problem of finding a change of coordinates such that the dynamics of a system can be written in reachable canonical form. Let  $A, B$  represent the dynamics of a given system and  $\tilde{A}, \tilde{B}$  be the dynamics in reachable canonical form. Suppose that we wish to transform the original system into reachable canonical form using a coordinate transformation  $z = Tx$ . As shown in the previous chapter, the dynamics matrix and the control matrix for the transformed system are

$$\tilde{A} = TAT^{-1}, \quad \tilde{B} = TB.$$

The reachability matrix for the transformed system then becomes

$$\tilde{W}_r = \begin{pmatrix} \tilde{B} & \tilde{A}\tilde{B} & \cdots & \tilde{A}^{n-1}\tilde{B} \end{pmatrix}.$$

Transforming each element individually, we have

$$\begin{aligned} \tilde{A}\tilde{B} &= TAT^{-1}TB = TAB, \\ \tilde{A}^2\tilde{B} &= (TAT^{-1})^2TB = TAT^{-1}TAT^{-1}TB = TA^2B, \\ &\vdots \\ \tilde{A}^n\tilde{B} &= TA^nB, \end{aligned}$$

and hence the reachability matrix for the transformed system is

$$\tilde{W}_r = T \begin{pmatrix} B & AB & \cdots & A^{n-1}B \end{pmatrix} = TW_r. \quad (7.8)$$

If  $W_r$  is invertible, we can thus solve for the transformation  $T$  that takes the system into reachable canonical form:

$$T = \tilde{W}_r W_r^{-1}.$$

The following example illustrates the approach.

### Example 7.3 Transformation to reachable form

Consider a simple two-dimensional system of the form

$$\frac{dx}{dt} = \begin{pmatrix} \alpha & \omega \\ -\omega & \alpha \end{pmatrix} x + \begin{pmatrix} 0 \\ 1 \end{pmatrix} u.$$

We wish to find the transformation that converts the system into reachable canonical form:

$$\tilde{A} = \begin{pmatrix} -a_1 & -a_2 \\ 1 & 0 \end{pmatrix}, \quad \tilde{B} = \begin{pmatrix} 1 \\ 0 \end{pmatrix}.$$

The coefficients  $a_1$  and  $a_2$  can be determined from the characteristic polynomial for the original system:

$$\lambda(s) = \det(sI - A) = s^2 - 2\alpha s + (\alpha^2 + \omega^2) \quad \implies \begin{aligned} a_1 &= -2\alpha, \\ a_2 &= \alpha^2 + \omega^2. \end{aligned}$$

The reachability matrix for each system is

$$W_r = \begin{pmatrix} 0 & \omega \\ 1 & \alpha \end{pmatrix}, \quad \tilde{W}_r = \begin{pmatrix} 1 & -a_1 \\ 0 & 1 \end{pmatrix}.$$

The transformation  $T$  becomes

$$T = \tilde{W}_r W_r^{-1} = \begin{pmatrix} -(a_1 + \alpha)/\omega & 1 \\ 1/\omega & 0 \end{pmatrix} = \begin{pmatrix} \alpha/\omega & 1 \\ 1/\omega & 0 \end{pmatrix},$$

and hence the coordinates

$$\begin{pmatrix} z_1 \\ z_2 \end{pmatrix} = Tx = \begin{pmatrix} \alpha x_1/\omega + x_2 \\ x_1/\omega \end{pmatrix}$$

put the system in reachable canonical form. ∇

We summarize the results of this section in the following theorem.

**Theorem 7.2** (Reachable canonical form). *Let  $A$  and  $B$  be the dynamics and control matrices for a reachable system and suppose that the characteristic polynomial for  $A$  is given by*

$$\det(sI - A) = s^n + a_1 s^{n-1} + \cdots + a_{n-1} s + a_n.$$

*Then there exists a transformation  $z = Tx$  such that in the transformed coordinates the dynamics and control matrices are in reachable canonical form (7.6).*

One important implication of this theorem is that for any reachable system, we can assume without loss of generality that the coordinates are chosen such that the system is in reachable canonical form. This is particularly useful for proofs, as we shall see later in this chapter. However, for high-order systems, small changes in the coefficients  $a_i$  can give large changes in the eigenvalues. Hence, the reachable canonical form is not always well conditioned and must be used with some care.

## 7.2 Stabilization by State Feedback

The state of a dynamical system is a collection of variables that permits prediction of the future evolution of a system given its future inputs. We now explore the idea of designing the dynamics of a system through feedback of the state. We will assume that the system to be controlled is described by a linear state model and has a single input (for simplicity). The feedback control law will be developed step by step using a single idea: the positioning of closed loop eigenvalues in desired locations.

### State Space Controller Structure

Figure 7.5 is a diagram of a typical control system using state feedback. The full system consists of the process dynamics, which we take to be linear, the controller

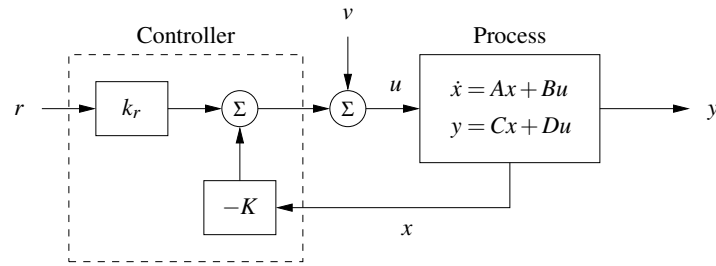

**Figure 7.5:** A feedback control system with state feedback. The controller uses the system state  $x$  and the reference input  $r$  to command the process through its input  $u$ . We model disturbances via the additive input  $v$ .

elements  $K$  and  $k_r$ , the reference input (or command signal)  $r$  and process disturbances  $v$ . The goal of the feedback controller is to regulate the output of the system  $y$  such that it tracks the reference input in the presence of disturbances and also uncertainty in the process dynamics.

An important element of the control design is the performance specification. The simplest performance specification is that of stability: given a constant reference  $r$  and in the absence of any disturbances, we would like the equilibrium point of the system to be asymptotically stable. More sophisticated performance specifications typically involve giving desired properties of the step or frequency response of the system, such as specifying the desired rise time, overshoot and settling time of the step response. Finally, we are often concerned with the disturbance attenuation properties of the system: to what extent can we experience disturbance inputs  $v$  and still hold the output  $y$  near the desired value?

Consider a system described by the linear differential equation

$$\frac{dx}{dt} = Ax + Bu, \quad y = Cx + Du, \quad (7.9)$$

where we have ignored the disturbance signal  $v$  for now. Our goal is to drive the output  $y$  to a given reference value  $r$  and hold it there.

We begin by assuming that all components of the state vector are measured. Since the state at time  $t$  contains all the information necessary to predict the future behavior of the system, the most general time-invariant control law is a function of the state and the reference input:

$$u = \alpha(x, r).$$

If the control law is restricted to be linear, it can be written as

$$u = -Kx + k_r r, \quad (7.10)$$

where  $r$  is the reference value, assumed for now to be a constant.

This control law corresponds to the structure shown in Figure 7.5. The negative sign is a convention to indicate that negative feedback is the normal situation. The term  $k_r r$  represents a feedforward signal from the reference to the control. The closed loop system obtained when the feedback (7.10) is applied to the sys-



tem (7.9) is given by

$$\frac{dx}{dt} = (A - BK)x + Bk_r r. \quad (7.11)$$

We attempt to determine the feedback gain  $K$  so that the closed loop system has the characteristic polynomial

$$p(s) = s^n + p_1 s^{n-1} + \cdots + p_{n-1} s + p_n. \quad (7.12)$$

This control problem is called the *eigenvalue assignment problem* or *pole placement problem* (we will define poles more formally in Chapter 9).

Note that  $k_r$  does not affect the stability of the system (which is determined by the eigenvalues of  $A - BK$ ) but does affect the steady-state solution. In particular, the equilibrium point and steady-state output for the closed loop system are given by

$$x_e = -(A - BK)^{-1} Bk_r r, \quad y_e = Cx_e + Du_e,$$

hence  $k_r$  should be chosen such that  $y_e = r$  (the desired output value). Since  $k_r$  is a scalar, we can easily solve to show that if  $D = 0$  (the most common case),

$$k_r = -1/(C(A - BK)^{-1}B). \quad (7.13)$$

Notice that  $k_r$  is exactly the inverse of the zero frequency gain of the closed loop system. The solution for  $D \neq 0$  is left as an exercise.

Using the gains  $K$  and  $k_r$ , we are thus able to design the dynamics of the closed loop system to satisfy our goal. To illustrate how to construct such a state feedback control law, we begin with a few examples that provide some basic intuition and insights.

#### Example 7.4 Vehicle steering

In Example 6.12 we derived a normalized linear model for vehicle steering. The dynamics describing the lateral deviation were given by

$$\begin{aligned} A &= \begin{pmatrix} 0 & 1 \\ 0 & 0 \end{pmatrix}, & B &= \begin{pmatrix} \gamma \\ 1 \end{pmatrix}, \\ C &= \begin{pmatrix} 1 & 0 \end{pmatrix}, & D &= 0. \end{aligned}$$

We want to design a controller that stabilizes the dynamics and tracks a given reference value  $r$  of the lateral position of the vehicle. To do this we introduce the feedback

$$u = -Kx + k_r r = -k_1 x_1 - k_2 x_2 + k_r r,$$

and the closed loop system becomes

$$\begin{aligned} \frac{dx}{dt} &= (A - BK)x + Bk_r r = \begin{pmatrix} -\gamma k_1 & 1 - \gamma k_2 \\ -k_1 & -k_2 \end{pmatrix} x + \begin{pmatrix} \gamma k_r \\ k_r \end{pmatrix} r, \\ y &= Cx + Du = \begin{pmatrix} 1 & 0 \end{pmatrix} x. \end{aligned} \quad (7.14)$$

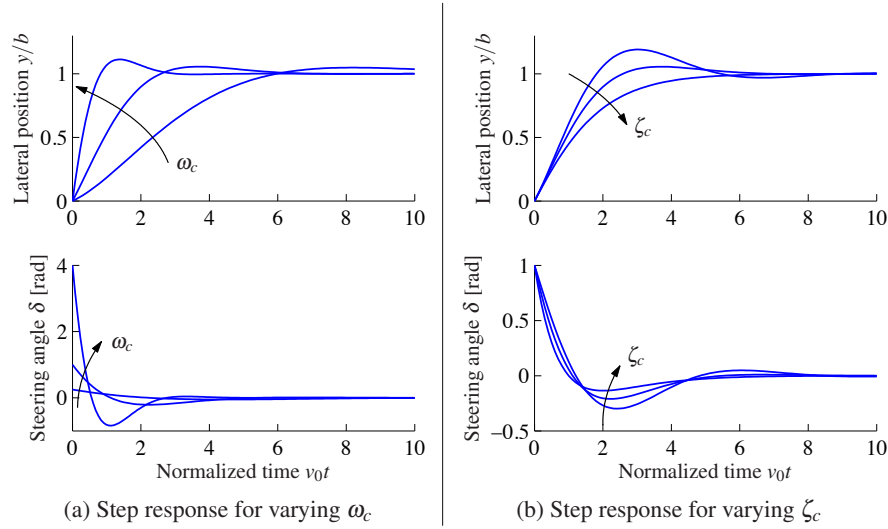

**Figure 7.6:** State feedback control of a steering system. Step responses (from zero initial condition) obtained with controllers designed with  $\zeta_c = 0.7$  and  $\omega_c = 0.5, 1$  and  $2$  [rad/s] are shown in (a). Notice that response speed increases with increasing  $\omega_c$ , but that large  $\omega_c$  also give large initial control actions. Step responses obtained with a controller designed with  $\omega_c = 1$  and  $\zeta_c = 0.5, 0.7$  and  $1$  are shown in (b).

The closed loop system has the characteristic polynomial

$$\det(sI - A + BK) = \det \begin{pmatrix} s + \gamma k_1 & \gamma k_2 - 1 \\ k_1 & s + k_2 \end{pmatrix} = s^2 + (\gamma k_1 + k_2)s + k_1.$$

Suppose that we would like to use feedback to design the dynamics of the system to have the characteristic polynomial

$$p(s) = s^2 + 2\zeta_c \omega_c s + \omega_c^2.$$

Comparing this polynomial with the characteristic polynomial of the closed loop system, we see that the feedback gains should be chosen as

$$k_1 = \omega_c^2, \quad k_2 = 2\zeta_c \omega_c - \gamma \omega_c^2.$$

Equation (7.13) gives  $k_r = k_1 = \omega_c^2$ , and the control law can be written as

$$u = k_1(r - x_1) - k_2 x_2 = \omega_c^2(r - x_1) - (2\zeta_c \omega_c - \gamma \omega_c^2)x_2.$$

The step responses for the closed loop system for different values of the design parameters are shown in Figure 7.6. The effect of  $\omega_c$  is shown in Figure 7.6a, which shows that the response speed increases with increasing  $\omega_c$ . The responses for  $\omega_c = 0.5$  and  $1$  have reasonable overshoot. The settling time is about 15 car lengths for  $\omega_c = 0.5$  (beyond the end of the plot) and decreases to about 6 car lengths for  $\omega_c = 1$ . The initial value of the control signal is  $u(0) = k_r = \omega_c^2 r$ , and thus the achievable response time is limited by the available actuator signal. Notice in particular the dramatic increase in control signal when  $\omega_c$  changes from 1 to 2.

The effect of  $\zeta_c$  is shown in Figure 7.6b. The response speed and the overshoot increase with decreasing damping. Using these plots, we conclude that reasonable values of the design parameters are to have  $\omega_c$  in the range of 0.5 to 1 and  $\zeta_c \approx 0.7$ .  $\nabla$

The example of the vehicle steering system illustrates how state feedback can be used to set the eigenvalues of a closed loop system to arbitrary values. We see that for this example we can set the eigenvalues to any location. We now show that this is a general property for reachable systems.

### State Feedback for Systems in Reachable Canonical Form

The reachable canonical form has the property that the parameters of the system are the coefficients of the characteristic polynomial. It is therefore natural to consider systems in this form when solving the eigenvalue assignment problem.

Consider a system in reachable canonical form, i.e.,

$$\begin{aligned} \frac{dz}{dt} = \tilde{A}z + \tilde{B}u &= \begin{pmatrix} -a_1 & -a_2 & -a_3 & \cdots & -a_n \\ 1 & 0 & 0 & \cdots & 0 \\ 0 & 1 & 0 & \cdots & 0 \\ \vdots & & \ddots & \ddots & \vdots \\ 0 & & & 1 & 0 \end{pmatrix} z + \begin{pmatrix} 1 \\ 0 \\ \vdots \\ 0 \\ 0 \end{pmatrix} u \\ y = \tilde{C}z &= \begin{pmatrix} b_1 & b_2 & \cdots & b_n \end{pmatrix} z. \end{aligned} \quad (7.15)$$

It follows from equation (7.7) that the open loop system has the characteristic polynomial

$$\det(sI - A) = s^n + a_1s^{n-1} + \cdots + a_{n-1}s + a_n.$$

Before making a formal analysis we can gain some insight by investigating the block diagram of the system shown in Figure 7.4. The characteristic polynomial is given by the parameters  $a_k$  in the figure. Notice that the parameter  $a_k$  can be changed by feedback from state  $z_k$  to the input  $u$ . It is thus straightforward to change the coefficients of the characteristic polynomial by state feedback.

Returning to equations, introducing the control law

$$u = -\tilde{K}z + k_r r = -\tilde{k}_1 z_1 - \tilde{k}_2 z_2 - \cdots - \tilde{k}_n z_n + k_r r, \quad (7.16)$$

the closed loop system becomes

$$\begin{aligned} \frac{dz}{dt} &= \begin{pmatrix} -a_1 - \tilde{k}_1 & -a_2 - \tilde{k}_2 & -a_3 - \tilde{k}_3 & \cdots & -a_n - \tilde{k}_n \\ 1 & 0 & 0 & \cdots & 0 \\ 0 & 1 & 0 & \cdots & 0 \\ \vdots & & \ddots & \ddots & \vdots \\ 0 & & & 1 & 0 \end{pmatrix} z + \begin{pmatrix} k_r \\ 0 \\ 0 \\ \vdots \\ 0 \end{pmatrix} r, \\ y &= \begin{pmatrix} b_1 & b_2 & \cdots & b_n \end{pmatrix} z. \end{aligned} \quad (7.17)$$

The feedback changes the elements of the first row of the  $A$  matrix, which corresponds to the parameters of the characteristic polynomial. The closed loop system thus has the characteristic polynomial

$$s^n + (a_1 + \tilde{k}_1)s^{n-1} + (a_2 + \tilde{k}_2)s^{n-2} + \cdots + (a_{n-1} + \tilde{k}_{n-1})s + a_n + \tilde{k}_n.$$

Requiring this polynomial to be equal to the desired closed loop polynomial

$$p(s) = s^n + p_1s^{n-1} + \cdots + p_{n-1}s + p_n,$$

we find that the controller gains should be chosen as

$$\tilde{k}_1 = p_1 - a_1, \quad \tilde{k}_2 = p_2 - a_2, \quad \dots \quad \tilde{k}_n = p_n - a_n.$$

This feedback simply replaces the parameters  $a_i$  in the system (7.15) by  $p_i$ . The feedback gain for a system in reachable canonical form is thus

$$\tilde{K} = \begin{pmatrix} p_1 - a_1 & p_2 - a_2 & \cdots & p_n - a_n \end{pmatrix}. \quad (7.18)$$

To have zero frequency gain equal to unity, we compute the equilibrium point  $z_e$  by setting the right hand side of equation (7.17) to zero and then compute the corresponding output. It can be seen that  $z_{e,1}, \dots, z_{e,n-1}$  must all be zero are we are left with

$$(-a_n - \tilde{k}_n)z_{e,n} + k_r r = 0 \quad \text{and} \quad y_e = b_n z_{e,n}.$$

It follows that in order for  $y_e$  to be equal to  $r$  then the parameter  $k_r$  should be chosen as

$$k_r = \frac{a_n + \tilde{k}_n}{b_n} = \frac{p_n}{b_n}. \quad (7.19)$$

Notice that it is essential to know the precise values of parameters  $a_n$  and  $b_n$  in order to obtain the correct zero frequency gain. The zero frequency gain is thus obtained by precise calibration. This is very different from obtaining the correct steady-state value by integral action, which we shall see in later sections.

### Eigenvalue Assignment

We have seen through the examples how feedback can be used to design the dynamics of a system through assignment of its eigenvalues. To solve the problem in the general case, we simply change coordinates so that the system is in reachable canonical form. Consider the system

$$\frac{dx}{dt} = Ax + Bu, \quad y = Cx + Du. \quad (7.20)$$

We can change the coordinates by a linear transformation  $z = Tx$  so that the transformed system is in reachable canonical form (7.15). For such a system the feedback is given by equation (7.16), where the coefficients are given by equation (7.18). Transforming back to the original coordinates gives the control law

$$u = -\tilde{K}z + k_r r = -\tilde{K}Tx + k_r r.$$

The form of the controller is a feedback term  $-Kx$  and a feedforward term  $k_r r$ .

The results obtained can be summarized as follows.

**Theorem 7.3** (Eigenvalue assignment by state feedback). *Consider the system given by equation (7.20), with one input and one output. Let  $\lambda(s) = s^n + a_1 s^{n-1} + \cdots + a_{n-1} s + a_n$  be the characteristic polynomial of  $A$ . If the system is reachable, then there exists a control law*

$$u = -Kx + k_r r$$

that gives a closed loop system with the characteristic polynomial

$$p(s) = s^n + p_1 s^{n-1} + \cdots + p_{n-1} s + p_n$$

and unity zero frequency gain between  $r$  and  $y$ . The feedback gain is given by

$$K = \tilde{K}T = \begin{pmatrix} p_1 - a_1 & p_2 - a_2 & \cdots & p_n - a_n \end{pmatrix} \tilde{W}_r W_r^{-1}, \quad (7.21)$$

where  $a_i$  are the coefficients of the characteristic polynomial of the matrix  $A$  and the matrices  $W_r$  and  $\tilde{W}_r$  are given by

$$W_r = \begin{pmatrix} B & AB & \cdots & A^{n-1}B \end{pmatrix}, \quad \tilde{W}_r = \begin{pmatrix} 1 & a_1 & a_2 & \cdots & a_{n-1} \\ 0 & 1 & a_1 & \cdots & a_{n-2} \\ \vdots & & \ddots & \ddots & \vdots \\ 0 & 0 & \cdots & 1 & a_1 \\ 0 & 0 & 0 & \cdots & 1 \end{pmatrix}^{-1}.$$

The reference gain is given by

$$k_r = -1 / (C(A - BK)^{-1}B).$$

For simple problems, the eigenvalue assignment problem can be solved by introducing the elements  $k_i$  of  $K$  as unknown variables. We then compute the characteristic polynomial

$$\lambda(s) = \det(sI - A + BK)$$

and equate coefficients of equal powers of  $s$  to the coefficients of the desired characteristic polynomial

$$p(s) = s^n + p_1 s^{n-1} + \cdots + p_{n-1} s + p_n.$$

This gives a system of linear equations to determine  $k_i$ . The equations can always be solved if the system is reachable, exactly as we did in Example 7.4.

Equation (7.21), which is called Ackermann's formula [Ack72, Ack85], can be used for numeric computations. It is implemented in the MATLAB function `acker`. The MATLAB function `place` is preferable for systems of high order because it is better conditioned numerically.

### Example 7.5 Predator-prey

Consider the problem of regulating the population of an ecosystem by modulating

the food supply. We use the predator–prey model introduced in Example 5.14 and described in more detail in Section 4.7. The dynamics for the system are given by

$$\begin{aligned}\frac{dH}{dt} &= (r+u)H \left(1 - \frac{H}{k}\right) - \frac{aHL}{c+H}, & H \geq 0, \\ \frac{dL}{dt} &= b \frac{aHL}{c+H} - dL, & L \geq 0.\end{aligned}$$

We choose the following nominal parameters for the system, which correspond to the values used in previous simulations:

$$\begin{aligned}a &= 3.2, & b &= 0.6, & c &= 50, \\ d &= 0.56, & k &= 125 & r &= 1.6.\end{aligned}$$

We take the parameter  $r$ , corresponding to the growth rate for hares, as the input to the system, which we might modulate by controlling a food source for the hares. This is reflected in our model by the term  $(r+u)$  in the first equation, where here  $r$  represents a constant parameter (not the reference signal) and  $u$  represents the controlled modulation. We choose the number of lynxes  $L$  as the output of our system.

To control this system, we first linearize the system around the equilibrium point of the system  $(H_e, L_e)$ , which can be determined numerically to be  $x_e \approx (20.6, 29.5)$ . This yields a linear dynamical system

$$\frac{d}{dt} \begin{pmatrix} z_1 \\ z_2 \end{pmatrix} = \begin{pmatrix} 0.13 & -0.93 \\ 0.57 & 0 \end{pmatrix} \begin{pmatrix} z_1 \\ z_2 \end{pmatrix} + \begin{pmatrix} 17.2 \\ 0 \end{pmatrix} v, \quad w = \begin{pmatrix} 0 & 1 \end{pmatrix} \begin{pmatrix} z_1 \\ z_2 \end{pmatrix},$$

where  $z_1 = H - H_e$ ,  $z_2 = L - L_e$  and  $v = u$ . It is easy to check that the system is reachable around the equilibrium  $(z, v) = (0, 0)$ , and hence we can assign the eigenvalues of the system using state feedback.

Selecting the eigenvalues of the closed loop system requires balancing the ability to modulate the input against the natural dynamics of the system. This can be done by the process of trial and error or by using some of the more systematic techniques discussed in the remainder of the text. For now, we simply choose the desired closed loop eigenvalues to be at  $\lambda = \{-0.1, -0.2\}$ . We can then solve for the feedback gains using the techniques described earlier, which results in

$$K = \begin{pmatrix} 0.025 & -0.052 \end{pmatrix}.$$

Finally, we solve for the reference gain  $k_r$ , using equation (7.13) to obtain  $k_r = 0.002$ .

Putting these steps together, our control law becomes

$$v = -Kz + k_r L_d,$$

where  $L_d$  is the desired number of lynxes. In order to implement the control law,

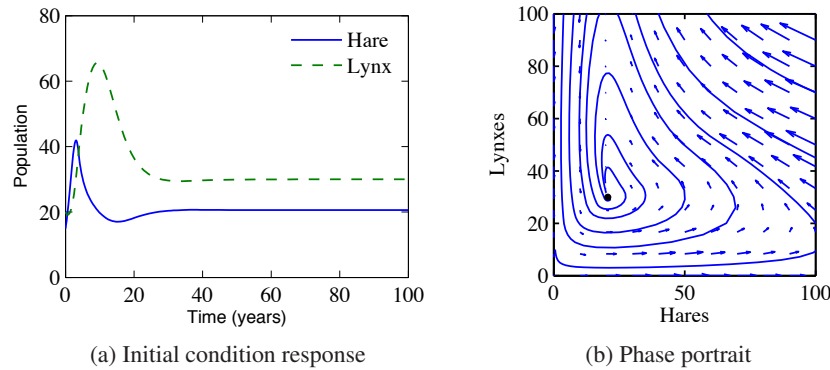

**Figure 7.7:** Simulation results for the controlled predator–prey system. The population of lynxes and hares as a function of time is shown in (a), and a phase portrait for the controlled system is shown in (b). Feedback is used to make the population stable at  $H_e = 20.6$  and  $L_e = 30$ .

we must rewrite it using the original coordinates for the system, yielding

$$\begin{aligned} u &= u_e - K(x - x_e) + k_r(L_d - y_e) \\ &= - \begin{pmatrix} 0.025 & -0.052 \end{pmatrix} \begin{pmatrix} H - 20.6 \\ L - 29.5 \end{pmatrix} + 0.002(L_d - 29.5). \end{aligned}$$

This rule tells us how much we should modulate  $u$  as a function of the current number of lynxes and hares in the ecosystem. Figure 7.7a shows a simulation of the resulting closed loop system using the parameters defined above and starting with an initial population of 15 hares and 20 lynxes. Note that the system quickly stabilizes the population of lynxes at the reference value ( $L_d = 30$ ). A phase portrait of the system is given in Figure 7.7b, showing how other initial conditions converge to the stabilized equilibrium population. Notice that the dynamics are very different from the natural dynamics (shown in Figure 4.20).  $\nabla$

The results of this section show that we can use state feedback to design the dynamics of a reachable system, under the strong assumption that we can measure all of the states. We shall address the availability of the states in the next chapter, when we consider output feedback and state estimation. In addition, Theorem 7.3, which states that the eigenvalues can be assigned to arbitrary locations, is also highly idealized and assumes that the dynamics of the process are known to high precision. The robustness of state feedback combined with state estimators is considered in Chapter 13 after we have developed the requisite tools.

### 7.3 Design Considerations

The location of the eigenvalues determines the behavior of the closed loop dynamics, and hence where we place the eigenvalues is the main design decision to be

made. As with all other feedback design problems, there are trade-offs among the magnitude of the control inputs, the robustness of the system to perturbations and the closed loop performance of the system. In this section we examine some of these trade-offs starting with the special case of second-order systems.

### Second-Order Systems

One class of systems that occurs frequently in the analysis and design of feedback systems is second-order linear differential equations. Because of their ubiquitous nature, it is useful to apply the concepts of this chapter to that specific class of systems and build more intuition about the relationship between stability and performance.

A canonical second-order system is a differential equation of the form

$$\ddot{q} + 2\zeta\omega_0\dot{q} + \omega_0^2q = k\omega_0^2u, \quad y = q. \quad (7.22)$$

In state space form, this system can be represented as

$$\frac{dx}{dt} = \begin{pmatrix} 0 & \omega_0 \\ -\omega_0 & -2\zeta\omega_0 \end{pmatrix} x + \begin{pmatrix} 0 \\ k\omega_0 \end{pmatrix} u, \quad y = \begin{pmatrix} 1 & 0 \end{pmatrix} x, \quad (7.23)$$

where  $x = (q, \dot{q}/\omega_0)$  represents a normalized choice of states. The eigenvalues of this system are given by

$$\lambda = -\zeta\omega_0 \pm \omega_0\sqrt{(\zeta^2 - 1)},$$

and we see that the system is stable if  $\omega_0 > 0$  and  $\zeta > 0$ . Note that the eigenvalues are complex if  $\zeta < 1$  and real otherwise. Equations (7.22) and (7.23) can be used to describe many second-order systems, including damped oscillators, active filters and flexible structures, as shown in the examples below.

The form of the solution depends on the value of  $\zeta$ , which is referred to as the *damping ratio* for the system. If  $\zeta > 1$ , we say that the system is *overdamped*, and the natural response ( $u = 0$ ) of the system is given by

$$y(t) = \frac{\beta x_{10} + x_{20}}{\beta - \alpha} e^{-\alpha t} - \frac{\alpha x_{10} + x_{20}}{\beta - \alpha} e^{-\beta t},$$

where  $\alpha = \omega_0(\zeta + \sqrt{\zeta^2 - 1})$  and  $\beta = \omega_0(\zeta - \sqrt{\zeta^2 - 1})$ . We see that the response consists of the sum of two exponentially decaying signals. If  $\zeta = 1$ , then the system is *critically damped* and solution becomes

$$y(t) = e^{-\zeta\omega_0 t} (x_{10} + (x_{20} + \zeta\omega_0 x_{10})t).$$

Note that this is still asymptotically stable as long as  $\omega_0 > 0$ , although the second term within the outer parentheses is increasing with time (but more slowly than the decaying exponential that is multiplying it).

Finally, if  $0 < \zeta < 1$ , then the solution is oscillatory and equation (7.22) is said



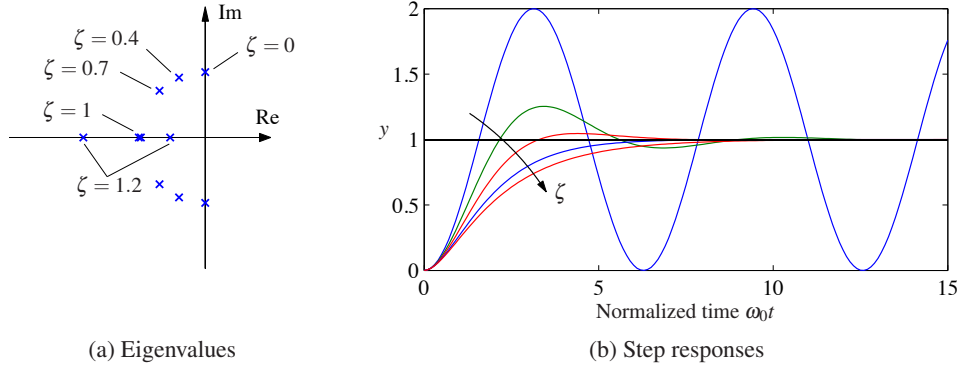

**Figure 7.8:** Step response for a second-order system. Normalized step responses for the system (7.23) for  $\zeta = 0, 0.4, 0.7, 1$  and  $1.2$ . As the damping ratio is increased, the rise time of the system gets longer, but there is less overshoot. The horizontal axis is in scaled units  $\omega_0 t$ ; higher values of  $\omega_0$  result in a faster response (rise time and settling time).

to be *underdamped*. The natural response of the system is given by

$$y(t) = e^{-\zeta\omega_0 t} \left( x_{10} \cos \omega_d t + \left( \frac{\zeta\omega_0}{\omega_d} x_{10} + \frac{1}{\omega_d} x_{20} \right) \sin \omega_d t \right),$$

where  $\omega_d = \omega_0 \sqrt{1 - \zeta^2}$  is called the *damped frequency*. For  $\zeta \ll 1$ ,  $\omega_d \approx \omega_0$  defines the oscillation frequency of the solution and  $\zeta$  gives the damping rate relative to  $\omega_0$ . The parameter  $\omega_0$  is referred to as the *natural frequency* of the system, stemming from the fact that for  $\zeta = 0$  the oscillation frequency is given by  $\omega_0$ .

Because of the simple form of a second-order system, it is possible to solve for the step and frequency responses in analytical form. The solution for the step response depends on the magnitude of  $\zeta$ :

$$y(t) = \begin{cases} k \left( 1 - e^{-\zeta\omega_0 t} \cos \omega_d t - \frac{\zeta}{\sqrt{1-\zeta^2}} e^{-\zeta\omega_0 t} \sin \omega_d t \right), & \zeta < 1; \\ k(1 - e^{-\omega_0 t}(1 + \omega_0 t)), & \zeta = 1; \\ k \left( 1 - \frac{1}{2} \left( \frac{\zeta}{\sqrt{\zeta^2-1}} + 1 \right) e^{-\omega_0 t(\zeta - \sqrt{\zeta^2-1})} \right. \\ \quad \left. + \frac{1}{2} \left( \frac{\zeta}{\sqrt{\zeta^2-1}} - 1 \right) e^{-\omega_0 t(\zeta + \sqrt{\zeta^2-1})} \right), & \zeta > 1, \end{cases} \quad (7.24)$$

where we have taken  $x(0) = 0$ . Note that for the lightly damped case ( $\zeta < 1$ ) we have an oscillatory solution at frequency  $\omega_d$ .

Step responses of systems with  $k = 1$  and different values of  $\zeta$  are shown in Figure 7.8. The shape of the response is determined by  $\zeta$ , and the speed of the response is determined by  $\omega_0$  (included in the time axis scaling): the response is faster if  $\omega_0$  is larger.

In addition to the explicit form of the solution, we can also compute the properties of the step response that were defined in Section 6.3. For example, to compute

**Table 7.1:** Properties of the step response for a second-order system with  $0 < \zeta < 1$ .

Property	Value	$\zeta = 0.5$	$\zeta = 1/\sqrt{2}$	$\zeta = 1$
Steady-state value	$k$	$k$	$k$	$k$
Rise time	$T_r \approx 1/\omega_0 \cdot e^{\varphi/\tan\varphi}$	$1.8/\omega_0$	$2.2/\omega_0$	$2.7/\omega_0$
Overshoot	$M_p = e^{-\pi\zeta/\sqrt{1-\zeta^2}}$	16%	4%	0%
Settling time (2%)	$T_s \approx 4/\zeta\omega_0$	$8.0/\omega_0$	$5.9/\omega_0$	$5.8/\omega_0$

the maximum overshoot for an underdamped system, we rewrite the output as

$$y(t) = k \left( 1 - \frac{1}{\sqrt{1-\zeta^2}} e^{-\zeta\omega_0 t} \sin(\omega_d t + \varphi) \right), \quad (7.25)$$

where  $\varphi = \arccos \zeta$ . The maximum overshoot will occur at the first time in which the derivative of  $y$  is zero, at which time the fraction of the final value can be shown to be

$$M_p = e^{-\pi\zeta/\sqrt{1-\zeta^2}}.$$

Similar computations can be done for the other characteristics of a step response. Table 7.1 summarizes the calculations.

The frequency response for a second-order system can also be computed explicitly and is given by

$$M e^{j\theta} = \frac{k\omega_0^2}{(i\omega)^2 + 2\zeta\omega_0(i\omega) + \omega_0^2} = \frac{k\omega_0^2}{\omega_0^2 - \omega^2 + 2i\zeta\omega_0\omega}.$$

A graphical illustration of the frequency response is given in Figure 7.9. Notice the resonant peak that increases with decreasing  $\zeta$ . The peak is often characterized by its  $Q$ -value, defined as  $Q = 1/2\zeta$ . The properties of the frequency response for a second-order system are summarized in Table 7.2.

**Table 7.2:** Properties of the frequency response for a second-order system with  $0 < \zeta < 1$ .

Property	Value	$\zeta = 0.1$	$\zeta = 0.5$	$\zeta = 1/\sqrt{2}$
Zero frequency gain	$M_0$	$k$	$k$	$k$
Bandwidth	$\omega_b$	$1.54\omega_0$	$1.27\omega_0$	$\omega_0$
Resonant peak gain	$M_r$	$1.54k$	$1.27k$	$k$
Resonant frequency	$\omega_{mr}$	$\omega_0$	$0.707\omega_0$	0

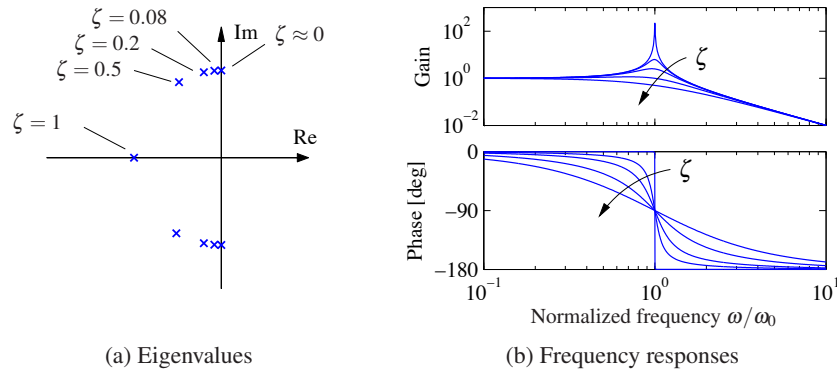

**Figure 7.9:** Frequency response of a second-order system (7.23). (a) Eigenvalues as a function of  $\zeta$ . (b) Frequency response as a function of  $\zeta$ . The upper curve shows the gain ratio  $M$ , and the lower curve shows the phase shift  $\theta$ . For small  $\zeta$  there is a large peak in the magnitude of the frequency response and a rapid change in phase centered at  $\omega = \omega_0$ . As  $\zeta$  is increased, the magnitude of the peak drops and the phase changes more smoothly between  $0^\circ$  and  $-180^\circ$ .

### Example 7.6 Drug administration

To illustrate the use of these formulas, consider the two-compartment model for drug administration, described in Section 4.6. The dynamics of the system are

$$\frac{dc}{dt} = \begin{pmatrix} -k_0 - k_1 & k_1 \\ k_2 & -k_2 \end{pmatrix} c + \begin{pmatrix} b_0 \\ 0 \end{pmatrix} u, \quad y = \begin{pmatrix} 0 & 1 \end{pmatrix} c,$$

where  $c_1$  and  $c_2$  are the concentrations of the drug in each compartment,  $k_i, i = 0, \dots, 2$  and  $b_0$  are parameters of the system,  $u$  is the flow rate of the drug into compartment 1 and  $y$  is the concentration of the drug in compartment 2. We assume that we can measure the concentrations of the drug in each compartment, and we would like to design a feedback law to maintain the output at a given reference value  $r$ .

We choose  $\zeta = 0.9$  to minimize the overshoot and additionally require the rise time to be  $T_r = 10$  min. Using the formulas in Table 7.1, this gives a value for  $\omega_0 = 0.22$ . We can now compute the gains to place the eigenvalues at this location. Setting  $u = -Kx + k_r r$ , the closed loop eigenvalues for the system satisfy

$$\lambda(s) = -0.2 \pm 0.096i.$$

Choosing  $k_1 = -0.2$  and  $k_2 = 0.2$  gives the desired closed loop behavior. Equation (7.13) gives the reference gain  $k_r = 0.065$ . The response of the controller is shown in Figure 7.10 and compared with an open loop strategy involving administering periodic doses of the drug.  $\nabla$

### Higher-Order Systems

Our emphasis so far has considered only second-order systems. For higher-order systems, eigenvalue assignment is considerably more difficult, especially when

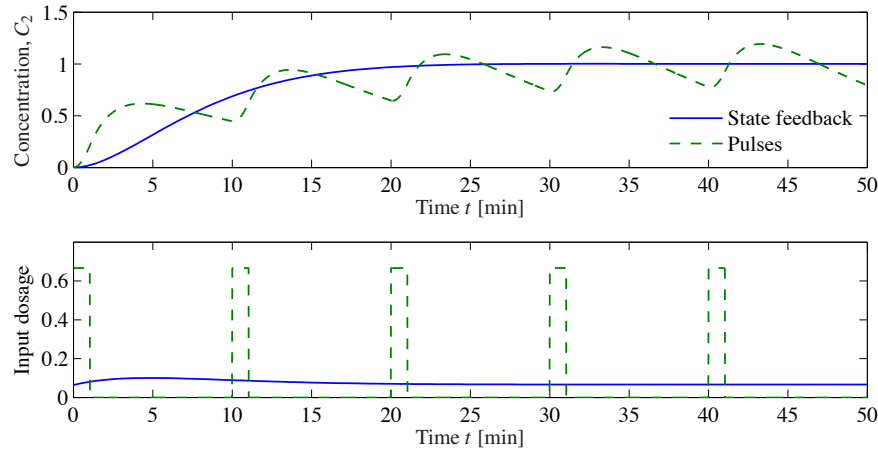

**Figure 7.10:** Open loop versus closed loop drug administration. Comparison between drug administration using a sequence of doses versus continuously monitoring the concentrations and adjusting the dosage continuously. In each case, the concentration is (approximately) maintained at the desired level, but the closed loop system has substantially less variability in drug concentration.

trying to account for the many trade-offs that are present in a feedback design.

One of the other reasons why second-order systems play such an important role in feedback systems is that even for more complicated systems the response is often characterized by the *dominant eigenvalues*. To define these more precisely, consider a stable system with eigenvalues  $\lambda_j$ ,  $j = 1, \dots, n$ . We say that a complex conjugate pair of eigenvalues  $\lambda$ ,  $\lambda^*$  is a *dominant pair* if they are the closest pair to the imaginary axis. In the case when multiple eigenvalues pairs are the same distance to the imaginary axis, a second criterion is to look at the relative damping of the system modes. We define the *damping ratio* for a complex eigenvalue  $\lambda$  to be

$$\zeta = \frac{-\operatorname{Re} \lambda}{|\lambda|}.$$

Given multiple complex conjugate pairs with the same real part, the dominant pair will be the set with the lowest damping ratio.

Assuming that a system is stable, the dominant pair of eigenvalues tends to be the most important element of the response. To see this, assume that we have a system in Jordan form with a simple Jordan block corresponding to the dominant pair of eigenvalues:

$$\frac{dz}{dt} = \begin{pmatrix} \lambda & & & & \\ & \lambda^* & & & \\ & & J_2 & & \\ & & & \ddots & \\ & & & & J_k \end{pmatrix} z + Bu, \quad y = Cz.$$

(Note that the state  $z$  may be complex because of the Jordan transformation.) The response of the system will be a linear combination of the responses from each of the individual Jordan subsystems. As we see from Figure 7.8, for  $\zeta < 1$  the subsystem with the slowest response is precisely the one with the whose eigenvalues are closest to the imaginary axis. Hence, when we add the responses from each of the individual subsystems, it is the dominant pair of eigenvalues that will be the primary factor after the initial transients due to the other terms in the solution die out. While this simple analysis does not always hold (e.g., if some nondominant terms have larger coefficients because of the particular form of the system), it is often the case that the dominant eigenvalues determine the (step) response of the system.

The only formal requirement for eigenvalue assignment is that the system be reachable. In practice there are many other constraints because the selection of eigenvalues has a strong effect on the magnitude and rate of change of the control signal. Large eigenvalues will in general require large control signals as well as fast changes of the signals. The capability of the actuators will therefore impose constraints on the possible location of closed loop eigenvalues. These issues will be discussed in depth in Chapters 12 and 13.

We illustrate some of the main ideas using the balance system as an example.

#### Example 7.7 Balance system

Consider the problem of stabilizing a balance system, whose dynamics were given in Example 7.2. The dynamics are given by

$$A = \begin{pmatrix} 0 & 0 & 1 & 0 \\ 0 & 0 & 0 & 1 \\ 0 & m^2 l^2 g / \mu & -c J_t / \mu & -\gamma J_t l m / \mu \\ 0 & M_t m g l / \mu & -c l m / \mu & -\gamma M_t / \mu \end{pmatrix}, \quad B = \begin{pmatrix} 0 \\ 0 \\ J_t / \mu \\ l m / \mu \end{pmatrix},$$

where  $M_t = M + m$ ,  $J_t = J + m l^2$ ,  $\mu = M_t J_t - m^2 l^2$  and we have left  $c$  and  $\gamma$  nonzero. We use the following parameters for the system (corresponding roughly to a human being balanced on a stabilizing cart):

$$\begin{aligned} M &= 10 \text{ kg}, & m &= 80 \text{ kg}, & c &= 0.1 \text{ N s/m}, & g &= 9.8 \text{ m/s}^2. \\ J &= 100 \text{ kg m}^2/\text{s}^2, & l &= 1 \text{ m}, & \gamma &= 0.01 \text{ N m s}, \end{aligned}$$

The eigenvalues of the open loop dynamics are given by  $\lambda \approx 0, -0.0011, -2.68, 2.68$ . We have verified already in Example 7.2 that the system is reachable, and hence we can use state feedback to stabilize the system and provide a desired level of performance.

To decide where to place the closed loop eigenvalues, we note that the closed loop dynamics will roughly consist of two components: a set of fast dynamics that stabilize the pendulum in the inverted position and a set of slower dynamics that control the position of the cart. For the fast dynamics, we look to the natural period of the pendulum (in the hanging-down position), which is given by  $\omega_0 = \sqrt{m g l / (J + m l^2)} \approx 2.1 \text{ rad/s}$ . To provide a fast response we choose a damping ratio

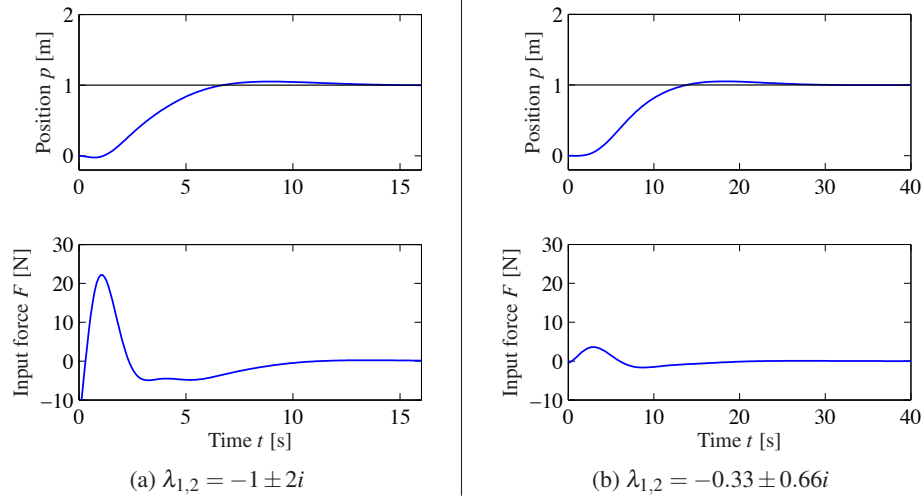

**Figure 7.11:** State feedback control of a balance system. The step response of a controller designed to give fast performance is shown in (a). Although the response characteristics (top left) look very good, the input magnitude (bottom left) is very large. A less aggressive controller is shown in (b). Here the response time is slowed down, but the input magnitude is much more reasonable. Both step responses are applied to the linearized dynamics.

of  $\zeta = 0.5$  and try to place the first pair of eigenvalues at  $\lambda_{1,2} \approx -\zeta \omega_0 \pm i \omega_0 \approx -1 \pm 2i$ , where we have used the approximation that  $\sqrt{1 - \zeta^2} \approx 1$ . For the slow dynamics, we choose the damping ratio to be 0.7 to provide a small overshoot and choose the natural frequency to be 0.5 to give a rise time of approximately 5 s. This gives eigenvalues  $\lambda_{3,4} = -0.35 \pm 0.35i$ .

The controller consists of a feedback on the state and a feedforward gain for the reference input. The feedback gain is given by

$$K = \begin{pmatrix} -15.6 & 1730 & -50.1 & 443 \end{pmatrix},$$

which can be computed using Theorem 7.3 or using the MATLAB `place` command. The feedforward gain is  $k_r = -1/(C(A - BK)^{-1}B) = -15.6$ . The step response for the resulting controller (applied to the linearized system) is given in Figure 7.11a. While the step response gives the desired characteristics, the input required (bottom left) is excessively large, almost three times the force of gravity at its peak.

To provide a more realistic response, we can redesign the controller to have slower dynamics. We see that the peak of the input force occurs on the fast time scale, and hence we choose to slow this down by approximately a factor of 3, leaving the damping ratio unchanged. We also slow down the second set of eigenvalues, with the intuition that we should move the position of the cart more slowly than we stabilize the pendulum dynamics. Leaving the damping ratio for the slow dynamics unchanged at 0.7 and changing the frequency to 1 (corresponding to a

rise time of approximately 10 s), the desired eigenvalues become

$$\lambda = \{-0.33 \pm 0.66i, -0.18 \pm 0.18i\}.$$

The performance of the resulting controller is shown in Figure 7.11b.  $\nabla$

As we see from this example, it can be difficult to decide where to place the eigenvalues using state feedback. This is one of the principal limitations of this approach, especially for systems of higher dimension. Optimal control, such as the linear quadratic regulator problem discussed next, is one approach that is available. One can also focus on the frequency response for performing the design, which is the subject of Chapters 9–13.

### Linear Quadratic Regulators



As an alternative to selecting the closed loop eigenvalue locations to accomplish a certain objective, the gains for a state feedback controller can instead be chosen by attempting to optimize a cost function. This can be particularly useful in helping balance the performance of the system with the magnitude of the inputs required to achieve that level of performance.

The infinite horizon, linear quadratic regulator (LQR) problem is one of the most common optimal control problems. Given a multi-input linear system

$$\frac{dx}{dt} = Ax + Bu, \quad x \in \mathbb{R}^n, u \in \mathbb{R}^p,$$

we attempt to minimize the quadratic cost function

$$\tilde{J} = \int_0^{\infty} (x^T Q_x x + u^T Q_u u) dt, \quad (7.26)$$

where  $Q_x \succeq 0$  and  $Q_u \succ 0$  are symmetric, positive (semi-) definite matrices of the appropriate dimensions. This cost function represents a trade-off between the distance of the state from the origin and the cost of the control input. By choosing the matrices  $Q_x$  and  $Q_u$ , we can balance the rate of convergence of the solutions with the cost of the control.

The solution to the LQR problem is given by a linear control law of the form

$$u = -Q_u^{-1} B^T P x,$$

where  $P \in \mathbb{R}^{n \times n}$  is a positive definite, symmetric matrix that satisfies the equation

$$PA + A^T P - PBQ_u^{-1} B^T P + Q_x = 0. \quad (7.27)$$

Equation (7.27) is called the *algebraic Riccati equation*. If the system is reachable, it can be shown that there is a unique positive definite matrix  $P$  satisfying equation (7.27) that makes the closed loop system stable. The MATLAB command `lqr` returns the optimal controller given  $A$ ,  $B$ ,  $Q_x$  and  $Q_u$ .

One of the key questions in LQR design is how to choose the weights  $Q_x$  and  $Q_u$ . To guarantee that a solution exists, we must have  $Q_x \succeq 0$  and  $Q_u \succ 0$ . In addition, there are certain “observability” conditions on  $Q_x$  that limit its choice. Here

we assume  $Q_x \succ 0$  to ensure that solutions to the algebraic Riccati equation always exist.

To choose specific values for the cost function weights  $Q_x$  and  $Q_u$ , we must use our knowledge of the system we are trying to control. A particularly simple choice is to use diagonal weights

$$Q_x = \begin{pmatrix} q_1 & & 0 \\ & \ddots & \\ 0 & & q_n \end{pmatrix}, \quad Q_u = \begin{pmatrix} \rho_1 & & 0 \\ & \ddots & \\ 0 & & \rho_n \end{pmatrix}.$$

For this choice of  $Q_x$  and  $Q_u$ , the individual diagonal elements describe how much each state and input (squared) should contribute to the overall cost. Hence, we can take states that should remain small and attach higher weight values to them. Similarly, we can penalize an input versus the states and other inputs through choice of the corresponding input weight  $\rho$ .

### Example 7.8 Vectored thrust aircraft

Consider the original dynamics of the system (3.29), written in state space form as

$$\frac{dz}{dt} = \begin{pmatrix} z_4 \\ z_5 \\ z_6 \\ -\frac{c}{m}z_4 \\ -g - \frac{c}{m}z_5 \\ 0 \end{pmatrix} + \begin{pmatrix} 0 \\ 0 \\ 0 \\ \frac{1}{m} \cos \theta F_1 - \frac{1}{m} \sin \theta F_2 \\ \frac{1}{m} \sin \theta F_1 + \frac{1}{m} \cos \theta F_2 \\ \frac{r}{J} F_1 \end{pmatrix}$$

(see also Example 6.4). The system parameters are  $m = 4$  kg,  $J = 0.0475$  kg m<sup>2</sup>,  $r = 0.25$  m,  $g = 9.8$  m/s<sup>2</sup>,  $c = 0.05$  N s/m, which corresponds to a scaled model of the system. The equilibrium point for the system is given by  $F_1 = 0$ ,  $F_2 = mg$  and  $z_e = (x_e, y_e, 0, 0, 0, 0)$ . To derive the linearized model near an equilibrium point, we compute the linearization according to equation (6.34):

$$A = \begin{pmatrix} 0 & 0 & 0 & 1 & 0 & 0 \\ 0 & 0 & 0 & 0 & 1 & 0 \\ 0 & 0 & 0 & 0 & 0 & 1 \\ 0 & 0 & -g & -c/m & 0 & 0 \\ 0 & 0 & 0 & 0 & -c/m & 0 \\ 0 & 0 & 0 & 0 & 0 & 0 \end{pmatrix}, \quad B = \begin{pmatrix} 0 & 0 \\ 0 & 0 \\ 0 & 0 \\ 1/m & 0 \\ 0 & 1/m \\ r/J & 0 \end{pmatrix},$$

$$C = \begin{pmatrix} 1 & 0 & 0 & 0 & 0 & 0 \\ 0 & 1 & 0 & 0 & 0 & 0 \end{pmatrix}, \quad D = \begin{pmatrix} 0 & 0 \\ 0 & 0 \end{pmatrix}.$$

Letting  $\xi = z - z_e$  and  $v = F - F_e$ , the linearized system is given by

$$\frac{d\xi}{dt} = A\xi + Bv, \quad y = C\xi.$$

It can be verified that the system is reachable.



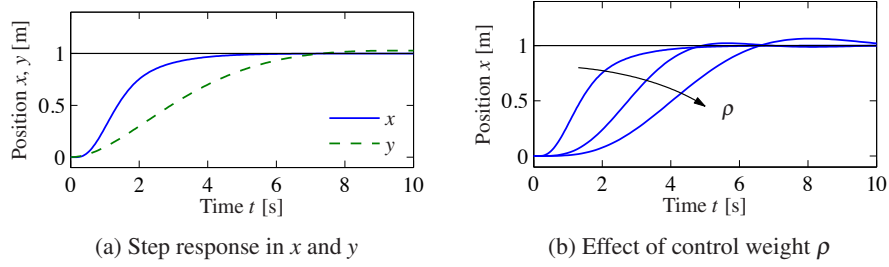

**Figure 7.12:** Step response for a vectored thrust aircraft. The plot in (a) shows the  $x$  and  $y$  positions of the aircraft when it is commanded to move 1 m in each direction. In (b) the  $x$  motion is shown for control weights  $\rho = 1, 10^2, 10^4$ . A higher weight of the input term in the cost function causes a more sluggish response.

To compute a linear quadratic regulator for the system, we write the cost function as

$$J = \int_0^{\infty} (\xi^T Q_{\xi} \xi + v^T Q_v v) dt,$$

where  $\xi = z - z_e$  and  $v = F - F_e$  again represent the local coordinates around the desired equilibrium point  $(z_e, F_e)$ . We begin with diagonal matrices for the state and input costs:

$$Q_{\xi} = \begin{pmatrix} 1 & 0 & 0 & 0 & 0 & 0 \\ 0 & 1 & 0 & 0 & 0 & 0 \\ 0 & 0 & 1 & 0 & 0 & 0 \\ 0 & 0 & 0 & 1 & 0 & 0 \\ 0 & 0 & 0 & 0 & 1 & 0 \\ 0 & 0 & 0 & 0 & 0 & 1 \end{pmatrix}, \quad Q_v = \begin{pmatrix} \rho & 0 \\ 0 & \rho \end{pmatrix}.$$

This gives a control law of the form  $v = -K\xi$ , which can then be used to derive the control law in terms of the original variables:

$$F = v + F_e = -K(z - z_e) + F_e.$$

As computed in Example 6.4, the equilibrium points have  $F_e = (0, mg)$  and  $z_e = (x_e, y_e, 0, 0, 0, 0)$ . The response of the controller to a step change in the desired position is shown in Figure 7.12a for  $\rho = 1$ . The response can be tuned by adjusting the weights in the LQR cost. Figure 7.12b shows the response in the  $x$  direction for different choices of the weight  $\rho$ .

▽

Linear quadratic regulators can also be designed for discrete-time systems, as illustrated by the following example.

### Example 7.9 Web server control

Consider the web server example given in Section 4.4, where a discrete-time model for the system was given. We wish to design a control law that sets the server parameters so that the average server processor load is maintained at a desired

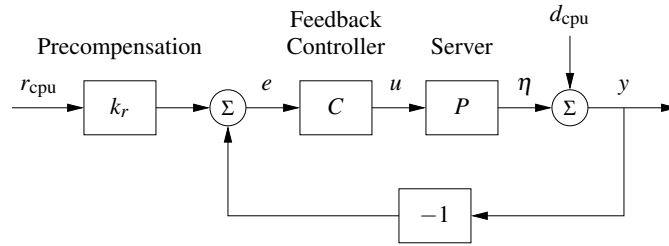

**Figure 7.13:** Feedback control of a web server. The controller sets the values of the web server parameters based on the difference between the nominal parameters (determined by  $k_r r$ ) and the current load  $y_{\text{cpu}}$ . The disturbance  $v$  represents the load due to other processes running on the server. Note that the measurement is taken after the disturbance so that we measure the total load on the server.

level. Since other processes may be running on the server, the web server must adjust its parameters in response to changes in the load.

A block diagram for the control system is shown in Figure 7.13. We focus on the special case where we wish to control only the processor load using both the `KeepAlive` and `MaxClients` parameters. We also include a “disturbance” on the measured load that represents the use of the processing cycles by other processes running on the server. The system has the same basic structure as the generic control system in Figure 7.5, with the variation that the disturbance enters after the process dynamics.

The dynamics of the system are given by a set of difference equations of the form

$$x[k+1] = Ax[k] + Bu[k], \quad y_{\text{cpu}}[k] = x_{\text{cpu}}[k] + d_{\text{cpu}}[k],$$

where  $x = (x_{\text{cpu}}, x_{\text{mem}})$  is the state of the web server,  $u = (u_{\text{ka}}, u_{\text{mc}})$  is the input,  $d_{\text{cpu}}$  is the processing load from other processes on the computer and  $y_{\text{cpu}}$  is the total processor load. The matrices  $A \in \mathbb{R}^{2 \times 2}$  and  $B \in \mathbb{R}^{2 \times 2}$  are described in Section 4.4.

We choose our controller to be a feedback controller of the form

$$u = -K \begin{pmatrix} y_{\text{cpu}} \\ x_{\text{mem}} \end{pmatrix} + k_r r_{\text{cpu}},$$

where  $r_{\text{cpu}}$  is the desired processor load. Note that we have used the measured processor load  $y_{\text{cpu}}$  instead of the CPU state  $x_{\text{cpu}}$  to ensure that we adjust the system operation based on the actual load. (This modification is necessary because of the nonstandard way in which the disturbance enters the process dynamics.)

The feedback gain matrix  $K$  can be chosen by any of the methods described in this chapter. Here we use a linear quadratic regulator, with the cost function given by

$$Q_x = \begin{pmatrix} 5 & 0 \\ 0 & 1 \end{pmatrix}, \quad Q_u = \begin{pmatrix} 1/50^2 & 0 \\ 0 & 1/1000^2 \end{pmatrix}.$$

The cost function for the state  $Q_x$  is chosen so that we place more emphasis on the processor load versus the memory use. The cost function for the inputs  $Q_u$  is chosen so as to normalize the two inputs, with a `KeepAlive` timeout of 50 s hav-

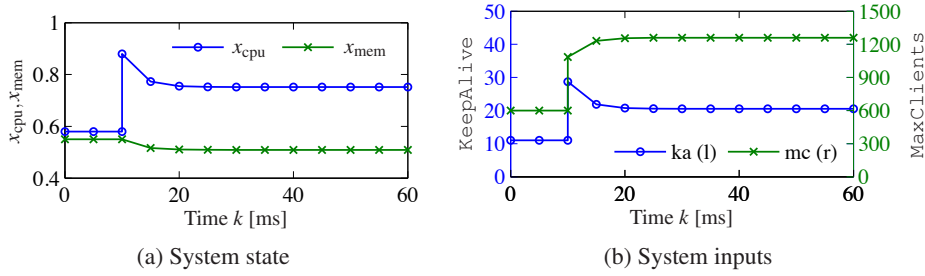

**Figure 7.14:** Web server with LQR control. The plot in (a) shows the state of the system under a change in external load applied at  $k = 10$  ms. The corresponding web server parameters (system inputs) are shown in (b). The controller is able to reduce the effect of the disturbance by approximately 40%.

ing the same weight as a `MaxClients` value of 1000. These values are squared since the cost associated with the inputs is given by  $u^T Q_u u$ . Using the dynamics in Section 4.4 and the `dlqr` command in MATLAB, the resulting gains become

$$K = \begin{pmatrix} -22.3 & 10.1 \\ 382.7 & 77.7 \end{pmatrix}.$$

As in the case of a continuous-time control system, the reference gain  $k_r$  is chosen to yield the desired equilibrium point for the system. Setting  $x[k+1] = x[k] = x_e$ , the steady-state equilibrium point and output for a given reference input  $r$  are given by

$$x_e = (A - BK)x_e + Bk_r r, \quad y_e = Cx_e.$$

This is a matrix equation in which  $k_r$  is a column vector that sets the two inputs values based on the desired reference. If we take the desired output to be of the form  $y_e = (r, 0)$ , then we must solve

$$\begin{pmatrix} 1 \\ 0 \end{pmatrix} = C(A - BK - I)^{-1} Bk_r.$$

Solving this equation for  $k_r$ , we obtain

$$k_r = \left( (C(A - BK - I)^{-1} B) \right)^{-1} \begin{pmatrix} 1 \\ 0 \end{pmatrix} = \begin{pmatrix} 49.3 \\ 539.5 \end{pmatrix}.$$

The dynamics of the closed loop system are illustrated in Figure 7.14. We apply a change in load of  $d_{\text{cpu}} = 0.3$  at time  $t = 10$  s, forcing the controller to adjust the operation of the server to attempt to maintain the desired load at 0.57. Note that both the `KeepAlive` and `MaxClients` parameters are adjusted. Although the load is decreased, it remains approximately 0.2 above the desired steady state. (Better results can be obtained using the techniques of the next section.)  $\nabla$

## 7.4 Integral Action

Controllers based on state feedback achieve the correct steady-state response to command signals by careful calibration of the gain  $k_r$ . However, one of the primary uses of feedback is to allow good performance in the presence of uncertainty, and hence requiring that we have an *exact* model of the process is undesirable. An alternative to calibration is to make use of integral feedback, in which the controller uses an integrator to provide zero steady-state error. The basic concept of integral feedback was introduced in Section 1.5; here we provide a more complete description and analysis.

The basic approach in integral feedback is to create a state within the controller that computes the integral of the error signal, which is then used as a feedback term. We do this by augmenting the description of the system with a new state  $z$ :

$$\frac{d}{dt} \begin{pmatrix} x \\ z \end{pmatrix} = \begin{pmatrix} Ax + Bu \\ y - r \end{pmatrix} = \begin{pmatrix} Ax + Bu \\ Cx - r \end{pmatrix}. \quad (7.28)$$

The state  $z$  is seen to be the integral of the difference between the the actual output  $y$  and desired output  $r$ . Note that if we find a controller  $u = \phi(x, z)$  that stabilizes the system, then we will necessarily have  $\dot{z} = 0$  in steady state and hence  $y = r$  in steady state.

Given the augmented system, we design a state space controller in the usual fashion, with a control law of the form

$$u = -Kx - k_i z + k_r r, \quad (7.29)$$

where  $K$  is the usual state feedback term,  $k_i$  is the integral term and  $k_r$  is used to set the nominal input for the desired steady state. The resulting equilibrium point for the system is given as

$$x_e = -(A - BK)^{-1} B(k_r r - k_i z_e), \quad Cx_e = r,$$

which comes from setting the right hand side of equation (7.28) to zero and substituting  $u$  from equation (7.29). Note that the value of  $z_e$  is not specified but rather will automatically settle to the value that makes  $\dot{z} = y - r = 0$ , which implies that at equilibrium the output will equal the reference value. This holds independently of the specific values of  $A$ ,  $B$  and  $K$  as long as the system is stable (which can be done through appropriate choice of  $K$  and  $k_i$ ).

The final control law is given by

$$u = -Kx - k_i z + k_r r, \quad \frac{dz}{dt} = y - r,$$

where we have now included the dynamics of the integrator as part of the specification of the controller. This type of control law is known as a *dynamic compensator* since it has its own internal dynamics. The following example illustrates the basic approach.

### Example 7.10 Cruise control

Consider the cruise control example introduced in Section 1.4 and considered fur-

ther in Example 6.11 (see also Section 4.1). The linearized dynamics of the process around an equilibrium point  $v_e, u_e$  are given by

$$\frac{dx}{dt} = ax - b_g\theta + bw, \quad y = v = x + v_e,$$

where  $x = v - v_e, w = u - u_e, m$  is the mass of the car and  $\theta$  is the angle of the road. The constant  $a$  depends on the throttle characteristic and is given in Example 6.11.

If we augment the system with an integrator, the process dynamics become

$$\frac{dx}{dt} = ax - b_g\theta + bw, \quad \frac{dz}{dt} = y - v_r = v_e + x - v_r,$$

or, in state space form,

$$\frac{d}{dt} \begin{pmatrix} x \\ z \end{pmatrix} = \begin{pmatrix} a & 0 \\ 1 & 0 \end{pmatrix} \begin{pmatrix} x \\ z \end{pmatrix} + \begin{pmatrix} b \\ 0 \end{pmatrix} w + \begin{pmatrix} -b_g \\ 0 \end{pmatrix} \theta + \begin{pmatrix} 0 \\ v_e - v_r \end{pmatrix}.$$

Note that when the system is at equilibrium, we have that  $\dot{z} = 0$ , which implies that the vehicle speed  $v = v_e + x$  should be equal to the desired reference speed  $v_r$ . Our controller will be of the form

$$\frac{dz}{dt} = y - v_r, \quad w = -k_p x - k_i z + k_r v_r,$$

and the gains  $k_p, k_i$  and  $k_r$  will be chosen to stabilize the system and provide the correct input for the reference speed.

Assume that we wish to design the closed loop system to have the characteristic polynomial

$$\lambda(s) = s^2 + a_1 s + a_2.$$

Setting the disturbance  $\theta = 0$ , the characteristic polynomial of the closed loop system is given by

$$\det(sI - (A - BK)) = s^2 + (bk_p - a)s + bk_i,$$

and hence we set

$$k_p = \frac{a_1 + a}{b}, \quad k_i = \frac{a_2}{b}, \quad k_r = -1 / (C(A - BK)^{-1}B) = \frac{a}{b}.$$

The resulting controller stabilizes the system and hence brings  $\dot{z} = y - v_r$  to zero, resulting in perfect tracking. Notice that even if we have a small error in the values of the parameters defining the system, as long as the closed loop eigenvalues are still stable, then the tracking error will approach zero. Thus the exact calibration required in our previous approach (using  $k_r$ ) is not needed here. Indeed, we can even choose  $k_r = 0$  and let the feedback controller do all of the work. However,  $k_r$  does influence the transient response to command signals and setting it properly will generally give a more favorable response.

Integral feedback can also be used to compensate for constant disturbances. Figure 7.15 shows the results of a simulation in which the car encounters a hill with angle  $\theta = 4^\circ$  at  $t = 8$  s. The stability of the system is not affected by this external disturbance, and so we once again see that the car's velocity converges

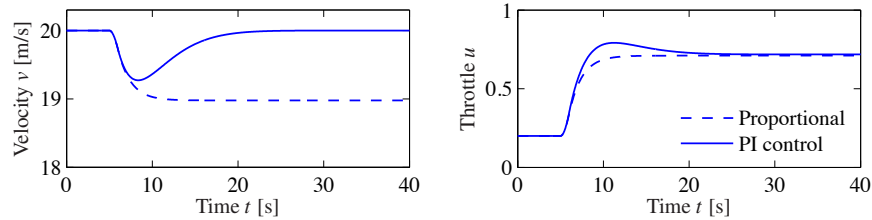

**Figure 7.15:** Velocity and throttle for a car with cruise control based on proportional (dashed) and PI control (solid). The PI controller is able to adjust the throttle to compensate for the effect of the hill and maintain the speed at the reference value of  $v_r = 20$  m/s. The controller gains are  $k_p = 0.5$  and  $k_i = 0.1$ .

to the reference speed. This ability to handle constant disturbances is a general property of controllers with integral feedback (see Exercise 7.4).  $\nabla$

## 7.5 Further Reading

The importance of state models and state feedback was discussed in the seminal paper by Kalman [Kal60], where the state feedback gain was obtained by solving an optimization problem that minimized a quadratic loss function. The notions of reachability and observability (Chapter 8) are also due to Kalman [Kal61b] (see also [Gil63, KHN63]). Kalman defines controllability and reachability as the ability to reach the origin and an arbitrary state, respectively [KFA69]. We note that in most textbooks the term “controllability” is used instead of “reachability,” but we prefer the latter term because it is more descriptive of the fundamental property of being able to reach arbitrary states. Most undergraduate textbooks on control contain material on state space systems, including, for example, Franklin, Powell and Emami-Naeini [FPEN05] and Ogata [Oga01]. Friedland’s textbook [Fri04] covers the material in the previous, current and next chapter in considerable detail, including the topic of optimal control.

## Exercises

**7.1** (Double integrator) Consider the double integrator. Find a piecewise constant control strategy that drives the system from the origin to the state  $x = (1, 1)$ .

**7.2** (Reachability from nonzero initial state) Extend the argument in Section 7.1 to show that if a system is reachable from an initial state of zero, it is reachable from a nonzero initial state.

**7.3** (Unreachable systems) Consider the system shown in Figure 7.3. Write the dynamics of the two systems as

$$\frac{dx}{dt} = Ax + Bu, \quad \frac{dz}{dt} = Az + Bu.$$

If  $x$  and  $z$  have the same initial condition, they will always have the same state regardless of the input that is applied. Show that this violates the definition of reachability and further show that the reachability matrix  $W_r$  is not full rank.

**7.4** (Integral feedback for rejecting constant disturbances) Consider a linear system of the form

$$\frac{dx}{dt} = Ax + Bu + Fd, \quad y = Cx$$

where  $u$  is a scalar and  $v$  is a disturbance that enters the system through a disturbance vector  $F \in \mathbb{R}^n$ . Assume that the matrix  $A$  is invertible and the zero frequency gain  $CA^{-1}B$  is nonzero. Show that integral feedback can be used to compensate for a constant disturbance by giving zero steady-state output error even when  $d \neq 0$ .

**7.5** (Rear-steered bicycle) A simple model for a bicycle was given by equation (4.5) in Section 4.2. A model for a bicycle with rear-wheel steering is obtained by reversing the sign of the velocity in the model. Determine the conditions under which this systems is reachable and explain any situations in which the system is not reachable.

**7.6** (Characteristic polynomial for reachable canonical form) Show that the characteristic polynomial for a system in reachable canonical form is given by equation (7.7) and that

$$\frac{d^n z_k}{dt^n} + a_1 \frac{d^{n-1} z_k}{dt^{n-1}} + \cdots + a_{n-1} \frac{dz_k}{dt} + a_n z_k = \frac{d^{n-k} u}{dt^{n-k}},$$

where  $z_k$  is the  $k$ th state.

**7.7** (Reachability matrix for reachable canonical form) Consider a system in reachable canonical form. Show that the inverse of the reachability matrix is given by

$$\tilde{W}_r^{-1} = \begin{pmatrix} 1 & a_1 & a_2 & \cdots & a_n \\ 0 & 1 & a_1 & \cdots & a_{n-1} \\ 0 & 0 & 1 & \ddots & \vdots \\ \vdots & & & \ddots & a_1 \\ 0 & 0 & 0 & \cdots & 1 \end{pmatrix}.$$

**7.8** (Non-maintainable equilibria) Consider the normalized model of a pendulum on a cart

$$\frac{d^2 x}{dt^2} = u, \quad \frac{d^2 \theta}{dt^2} = -\theta + u,$$

where  $x$  is cart position and  $\theta$  is pendulum angle. Can the angle  $\theta = \theta_0$  for  $\theta_0 \neq 0$  be maintained?

**7.9** (Eigenvalue assignment for unreachable system) Consider the system

$$\frac{dx}{dt} = \begin{pmatrix} 0 & 1 \\ 0 & 0 \end{pmatrix} x + \begin{pmatrix} 1 \\ 0 \end{pmatrix} u, \quad y = \begin{pmatrix} 1 & 0 \end{pmatrix} x,$$

with the control law

$$u = -k_1x_1 - k_2x_2 + k_r r.$$

Compute the rank of the reachability matrix for the system and show that eigenvalues of the system cannot be assigned to arbitrary values.

**7.10** (Cayley–Hamilton theorem) Let  $A \in \mathbb{R}^{n \times n}$  be a matrix with characteristic polynomial  $\lambda(s) = \det(sI - A) = s^n + a_1s^{n-1} + \cdots + a_{n-1}s + a_n$ . Assume that the matrix  $A$  can be diagonalized and show that it satisfies

$$\lambda(A) = A^n + a_1A^{n-1} + \cdots + a_{n-1}A + a_nI = 0,$$

Use the result to show that  $A^k$ ,  $k \geq n$ , can be rewritten in terms of powers of  $A$  of order less than  $n$ .

**7.11** (Dominant pairs)

**7.12** (Motor drive) Consider the normalized model of the motor drive in Exercise ???. Using the following normalized parameters,

$$J_1 = 10/9, \quad J_2 = 10, \quad c = 0.1, \quad k = 1, \quad k_I = 1,$$

verify that the eigenvalues of the open loop system are  $0, 0, -0.05 \pm i$ . Design a state feedback that gives a closed loop system with eigenvalues  $-2, -1$  and  $-1 \pm i$ . This choice implies that the oscillatory eigenvalues will be well damped and that the eigenvalues at the origin are replaced by eigenvalues on the negative real axis. Simulate the responses of the closed loop system to step changes in the command signal for  $\theta_2$  and a step change in a disturbance torque on the second rotor.

**7.13** (Whipple bicycle model) Consider the Whipple bicycle model given by equation (4.7) in Section 4.2. Using the parameters from the companion web site, the model is unstable at the velocity  $v = 5$  m/s and the open loop eigenvalues are  $-1.84, -14.29$  and  $1.30 \pm 4.60i$ . Find the gains of a controller that stabilizes the bicycle and gives closed loop eigenvalues at  $-2, -10$  and  $-1 \pm i$ . Simulate the response of the system to a step change in the steering reference of  $0.002$  rad.

**7.14** (Atomic force microscope) Consider the model of an AFM in contact mode given in Example 6.9:

$$\frac{dx}{dt} = \begin{pmatrix} 0 & 1 & 0 & 0 \\ -k_2/(m_1 + m_2) & -c_2/(m_1 + m_2) & 1/m_2 & 0 \\ 0 & 0 & 0 & \omega_3 \\ 0 & 0 & -\omega_3 & -2\zeta_3\omega_3 \end{pmatrix} x + \begin{pmatrix} 0 \\ 0 \\ 0 \\ \omega_3 \end{pmatrix} u,$$

$$y = \frac{m_2}{m_1 + m_2} \begin{pmatrix} m_1k_2 & m_1c_2 & 1 & 0 \end{pmatrix} x.$$

Use the MATLAB script `afm_data.m` from the companion web site to generate the system matrices.

(a) Compute the reachability matrix of the system and numerically determine its rank. Scale the model by using milliseconds instead of seconds as time units. Repeat the calculation of the reachability matrix and its rank.



- (b) Find a state feedback controller that gives a closed loop system with complex poles having damping ratio 0.707. Use the scaled model for the computations.
- (c) Compute state feedback gains using linear quadratic control. Experiment by using different weights. Compute the gains for  $q_1 = q_2 = 0, q_3 = q_4 = 1$  and  $\rho_1 = 0.1$  and explain the result. Choose  $q_1 = q_2 = q_3 = q_4 = 1$  and explore what happens to the feedback gains and closed loop eigenvalues when you change  $\rho_1$ . Use the scaled system for this computation.

**7.15** Consider the second-order system

$$\frac{d^2y}{dt^2} + 0.5\frac{dy}{dt} + y = a\frac{du}{dt} + u.$$

Let the initial conditions be zero.

- (a) Show that the initial slope of the unit step response is  $a$ . Discuss what it means when  $a < 0$ .
- (b) Show that there are points on the unit step response that are invariant with  $a$ . Discuss qualitatively the effect of the parameter  $a$  on the solution.
- (c) Simulate the system and explore the effect of  $a$  on the rise time and overshoot.

**7.16** (Bryson's rule) Bryson and Ho [BH75] have suggested the following method for choosing the matrices  $Q_x$  and  $Q_u$  in equation (7.26). Start by choosing  $Q_x$  and  $Q_u$  as diagonal matrices whose elements are the inverses of the squares of the maxima of the corresponding variables. Then modify the elements to obtain a compromise among response time, damping and control effort. Apply this method to the motor drive in Exercise 7.12. Assume that the largest values of the  $\phi_1$  and  $\phi_2$  are 1, the largest values of  $\dot{\phi}_1$  and  $\dot{\phi}_2$  are 2 and the largest control signal is 10. Simulate the closed loop system for  $\phi_2(0) = 1$  and all other states are initialized to 0. Explore the effects of different values of the diagonal elements for  $Q_x$  and  $Q_u$ .



---

## Chapter Eight

### Output Feedback

*One may separate the problem of physical realization into two stages: computation of the “best approximation”  $\hat{x}(t_1)$  of the state from knowledge of  $y(t)$  for  $t \leq t_1$  and computation of  $u(t_1)$  given  $\hat{x}(t_1)$ .*

R. E. Kalman, “Contributions to the Theory of Optimal Control,” 1960 [Kal60].

In this chapter we show how to use output feedback to modify the dynamics of the system through the use of observers. We introduce the concept of observability and show that if a system is observable, it is possible to recover the state from measurements of the inputs and outputs to the system. We then show how to design a controller with feedback from the observer state. An important concept is the separation principle quoted above, which is also proved. The structure of the controllers derived in this chapter is quite general and is used by many other design methods.

#### 8.1 Observability

In Section 7.2 of the previous chapter it was shown that it is possible to find a state feedback law that gives desired closed loop eigenvalues provided that the system is reachable and that all the states are measured by sensors. For many situations, it is highly unrealistic to assume that all the states are measured. In this section we investigate how the state can be estimated by using a mathematical model and a few measurements. It will be shown that computation of the states can be carried out by a dynamical system called an *observer*.

##### Definition of Observability

Consider a system described by a set of differential equations

$$\frac{dx}{dt} = Ax + Bu, \quad y = Cx + Du, \quad (8.1)$$

where  $x \in \mathbb{R}^n$  is the state,  $u \in \mathbb{R}^p$  the input and  $y \in \mathbb{R}^q$  the measured output. We wish to estimate the state of the system from its inputs and outputs, as illustrated in Figure 8.1. In some situations we will assume that there is only one measured signal, i.e., that the signal  $y$  is a scalar and that  $C$  is a (row) vector. This signal may be corrupted by noise  $w$ , although we shall start by considering the noise-free case. We write  $\hat{x}$  for the state estimate given by the observer.

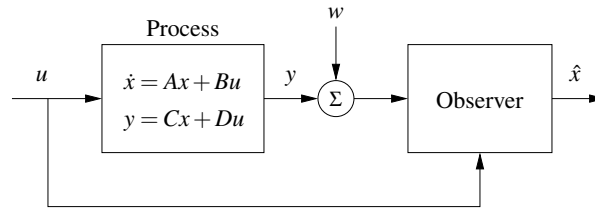

**Figure 8.1:** Block diagram for an observer. The observer uses the process measurement  $y$  (possibly corrupted by noise  $w$ ) and the input  $u$  to estimate the current state of the process, denoted  $\hat{x}$ .

**Definition 8.1** (Observability). A linear system is *observable* if for any  $T > 0$  it is possible to determine the state of the system  $x(T)$  through measurements of  $y(t)$  and  $u(t)$  on the interval  $[0, T]$ .

The definition above holds for nonlinear systems as well, and the results discussed here have extensions to the nonlinear case.

The problem of observability is one that has many important applications, even outside feedback systems. If a system is observable, then there are no “hidden” dynamics inside it; we can understand everything that is going on through observation (over time) of the inputs and outputs. As we shall see, the problem of observability is of significant practical interest because it will determine if a set of sensors is sufficient for controlling a system. Sensors combined with a mathematical model of the system can also be viewed as a “virtual sensor” that gives information about variables that are not measured directly. The process of reconciling signals from many sensors using mathematical models is also called *sensor fusion*.

### Testing for Observability

When discussing reachability in the previous chapter, we neglected the output and focused on the state. Similarly, it is convenient here to initially neglect the input and focus on the autonomous system

$$\frac{dx}{dt} = Ax, \quad y = Cx. \quad (8.2)$$

We wish to understand when it is possible to determine the state from observations of the output.

The output itself gives the projection of the state onto vectors that are rows of the matrix  $C$ . The observability problem can immediately be solved if the matrix  $C$  is invertible. If the matrix is not invertible, we can take derivatives of the output to obtain

$$\frac{dy}{dt} = C \frac{dx}{dt} = CAx.$$

From the derivative of the output we thus get the projection of the state on vectors

that are rows of the matrix  $CA$ . Proceeding in this way, we get at every time  $t$

$$\begin{pmatrix} y(t) \\ \dot{y}(t) \\ \ddot{y}(t) \\ \vdots \\ y^{(n-1)}(t) \end{pmatrix} = \begin{pmatrix} C \\ CA \\ CA^2 \\ \vdots \\ CA^{n-1} \end{pmatrix} x(t). \quad (8.3)$$

We thus find that the state at time  $t$  can be determined from the output and its derivatives at time  $t$  if the *observability matrix*

$$W_o = \begin{pmatrix} C \\ CA \\ CA^2 \\ \vdots \\ CA^{n-1} \end{pmatrix} \quad (8.4)$$

has  $n$  independent rows. As in the case of reachability, it turns out that we need not consider any derivatives higher than  $n - 1$  (this is an application of the Cayley–Hamilton theorem [Exercise 7.10]).

The calculation can easily be extended to systems with inputs. The state is then given by a linear combination of inputs and outputs and their higher derivatives. The observability criterion is unchanged. We leave this case as an exercise for the reader.

In practice, differentiation of the output can give large errors when there is measurement noise, and therefore the method sketched above is not particularly practical. We will address this issue in more detail in the next section, but for now we have the following basic result.

**Theorem 8.1** (Observability rank condition). *A linear system of the form (8.1) is observable if and only if the observability matrix  $W_o$  is invertible (full rank).*

*Proof.* The sufficiency of the observability rank condition follows from the analysis above. To prove necessity, suppose that the system is observable but  $W_o$  is not invertible. Let  $v \in \mathbb{R}^n$ ,  $v \neq 0$ , be a vector in the null space of  $W_o$ , so that  $W_o v = 0$ . If we let  $x(0) = v$  be the initial condition for the system and choose  $u = 0$ , then the output is given by  $y(t) = Ce^{At}v$ . Since  $e^{At}$  can be written as a power series in  $A$  and since  $A^n$  and higher powers can be rewritten in terms of lower powers of  $A$  (by the Cayley–Hamilton theorem), it follows that  $y(t)$  will be identically zero (the reader should fill in the missing steps. However, if both the input and output of the system are 0, then a valid estimate of the state is  $\hat{x} = 0$  for all time, which is clearly incorrect since  $x(0) = v \neq 0$ . Hence by contradiction we must have that  $W_o$  is invertible if the system is observable.  $\square$



### Example 8.1 Compartment model

Consider the two-compartment model in Figure 4.18a, but assume that only the

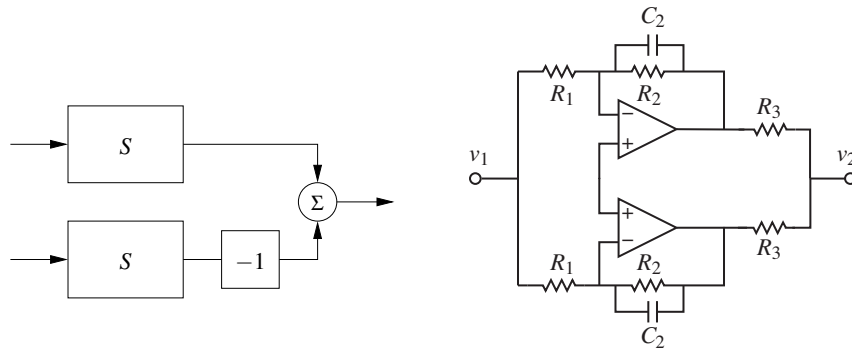

**Figure 8.2:** An unobservable system. Two identical subsystems have outputs that add together to form the overall system output. The individual states of the subsystem cannot be determined since the contributions of each to the output are not distinguishable. The circuit diagram on the right is an example of such a system.

concentration in the first compartment can be measured. The system is described by the linear system

$$\frac{dc}{dt} = \begin{pmatrix} -k_0 - k_1 & k_1 \\ k_2 & -k_2 \end{pmatrix} c + \begin{pmatrix} b_0 \\ 0 \end{pmatrix} u, \quad y = \begin{pmatrix} 1 & 0 \end{pmatrix} c.$$

The first compartment represents the drug concentration in the blood plasma, and the second compartment the drug concentration in the tissue where it is active. To determine if it is possible to find the concentration in the tissue compartment from a measurement of blood plasma, we investigate the observability of the system by forming the observability matrix

$$W_o = \begin{pmatrix} C \\ CA \end{pmatrix} = \begin{pmatrix} 1 & 0 \\ -k_0 - k_1 & k_1 \end{pmatrix}.$$

The rows are linearly independent if  $k_1 \neq 0$ , and under this condition it is thus possible to determine the concentration of the drug in the active compartment from measurements of the drug concentration in the blood.  $\nabla$

It is useful to have an understanding of the mechanisms that make a system unobservable. Such a system is shown in Figure 8.2. The system is composed of two identical systems whose outputs are subtracted. It seems intuitively clear that it is not possible to deduce the states from the output since we cannot deduce the individual output contributions from the difference. This can also be seen formally (Exercise 8.2).

### Observable Canonical Form

As in the case of reachability, certain canonical forms will be useful in studying observability. A linear single-input, single-output state space system is in *observ-*

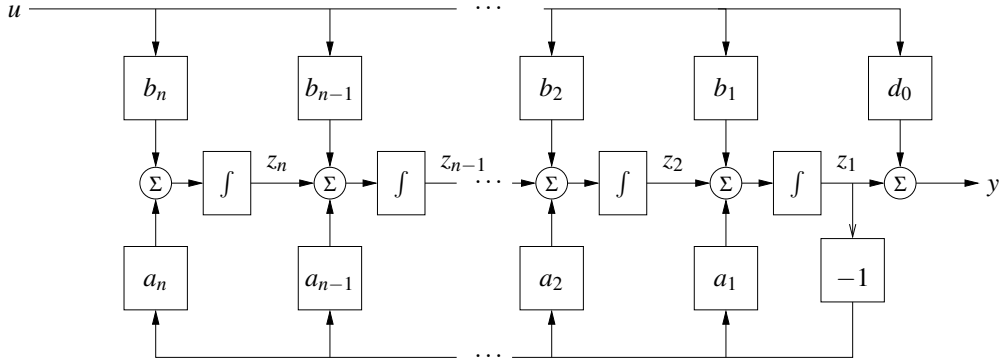

**Figure 8.3:** Block diagram of a system in observable canonical form. The states of the system are represented by individual integrators whose inputs are a weighted combination of the next integrator in the chain, the first state (rightmost integrator) and the system input. The output is a combination of the first state and the input.

*able canonical form* if its dynamics are given by

$$\frac{dz}{dt} = \begin{pmatrix} -a_1 & 1 & 0 & \cdots & 0 \\ -a_2 & 0 & 1 & & 0 \\ \vdots & & & \ddots & \\ -a_{n-1} & 0 & 0 & & 1 \\ -a_n & 0 & 0 & \cdots & 0 \end{pmatrix} z + \begin{pmatrix} b_1 \\ b_2 \\ \vdots \\ b_{n-1} \\ b_n \end{pmatrix} u,$$

$$y = \begin{pmatrix} 1 & 0 & 0 & \cdots & 0 \end{pmatrix} z + d_0 u.$$

The definition can be extended to systems with many inputs; the only difference is that the vector multiplying  $u$  is replaced by a matrix.

Figure 8.3 is a block diagram for a system in observable canonical form. As in the case of reachable canonical form, we see that the coefficients in the system description appear directly in the block diagram. The characteristic polynomial for a system in observable canonical form is

$$\lambda(s) = s^n + a_1 s^{n-1} + \cdots + a_{n-1} s + a_n. \quad (8.5)$$

It is possible to reason about the observability of a system in observable canonical form by studying the block diagram. If the input  $u$  and the output  $y$  are available, the state  $z_1$  can clearly be computed. Differentiating  $z_1$ , we obtain the input to the integrator that generates  $z_1$ , and we can now obtain  $z_2 = \dot{z}_1 + a_1 z_1 - b_1 u$ . Proceeding in this way, we can compute all states. The computation will, however, require that the signals be differentiated.

To check observability more formally, we compute the observability matrix for

a system in observable canonical form, which is given by

$$\tilde{W}_o = \begin{pmatrix} 1 & 0 & 0 & \dots & 0 \\ -a_1 & 1 & 0 & \dots & 0 \\ -a_1^2 - a_2 & -a_1 & 1 & & 0 \\ \vdots & \vdots & & \ddots & \vdots \\ * & * & & \dots & 1 \end{pmatrix},$$

where \* represents an entry whose exact value is not important. The rows of this matrix are linearly independent (since it is lower triangular), and hence  $W_o$  is invertible. A straightforward but tedious calculation shows that the inverse of the observability matrix has a simple form given by

$$\tilde{W}_o^{-1} = \begin{pmatrix} 1 & 0 & 0 & \dots & 0 \\ a_1 & 1 & 0 & \dots & 0 \\ a_2 & a_1 & 1 & \dots & 0 \\ \vdots & \vdots & & \ddots & \vdots \\ a_{n-1} & a_{n-2} & a_{n-3} & \dots & 1 \end{pmatrix}.$$

As in the case of reachability, it turns out that if a system is observable if and only if there always exists a transformation  $T$  that converts the system into observable canonical form. This is useful for proofs since it lets us assume that a system is in observable canonical form without any loss of generality. The observable canonical form may be poorly conditioned numerically.

## 8.2 State Estimation

Having defined the concept of observability, we now return to the question of how to construct an observer for a system. We will look for observers that can be represented as linear dynamical systems that take the inputs and outputs of the system we are observing and produces an estimate of the system's state. That is, we wish to construct a dynamical system of the form

$$\frac{d\hat{x}}{dt} = F\hat{x} + Gu + Hy,$$

where  $u$  and  $y$  are the input and output of the original system and  $\hat{x} \in \mathbb{R}^n$  is an estimate of the state with the property that  $\hat{x}(t) \rightarrow x(t)$  as  $t \rightarrow \infty$ .

### The Observer

We consider the system in equation (8.1) with  $D$  set to zero to simplify the exposition:

$$\frac{dx}{dt} = Ax + Bu, \quad y = Cx. \quad (8.6)$$



We can attempt to determine the state simply by simulating the equations with the correct input. An estimate of the state is then given by

$$\frac{d\hat{x}}{dt} = A\hat{x} + Bu. \quad (8.7)$$

To find the properties of this estimate, introduce the estimation error  $\tilde{x} = x - \hat{x}$ . It follows from equations (8.6) and (8.7) that

$$\frac{d\tilde{x}}{dt} = A\tilde{x}.$$

If matrix  $A$  has all its eigenvalues in the left half-plane, the error  $\tilde{x}$  will go to zero, and hence equation (8.7) is a dynamical system whose output converges to the state of the system (8.6). However, the convergence might be slower than desired.

The observer given by equation (8.7) uses only the process input  $u$ ; the measured signal does not appear in the equation. We must also require that the system be stable, and essentially our estimator converges because the state of both the observer and the estimator are going to zero. This is not very useful in a control design context since we want to have our estimate converge quickly to a nonzero state so that we can make use of it in our controller. We will therefore attempt to modify the observer so that the output is used and its convergence properties can be designed to be fast relative to the system's dynamics. This version will also work for unstable systems.

Consider the observer

$$\frac{d\hat{x}}{dt} = A\hat{x} + Bu + L(y - C\hat{x}). \quad (8.8)$$

This can be considered as a generalization of equation (8.7). Feedback from the measured output is provided by adding the term  $L(y - C\hat{x})$ , which is proportional to the difference between the observed output and the output predicted by the observer. It follows from equations (8.6) and (8.8) that

$$\frac{d\tilde{x}}{dt} = (A - LC)\tilde{x}.$$

If the matrix  $L$  can be chosen in such a way that the matrix  $A - LC$  has eigenvalues with negative real parts, the error  $\tilde{x}$  will go to zero. The convergence rate is determined by an appropriate selection of the eigenvalues.

Notice the similarity between the problems of finding a state feedback and finding the observer. State feedback design by eigenvalue assignment is equivalent to finding a matrix  $K$  so that  $A - BK$  has given eigenvalues. Designing an observer with prescribed eigenvalues is equivalent to finding a matrix  $L$  so that  $A - LC$  has given eigenvalues. Since the eigenvalues of a matrix and its transpose are the same we can establish the following equivalences:

$$A \leftrightarrow A^T, \quad B \leftrightarrow C^T, \quad K \leftrightarrow L^T, \quad W_r \leftrightarrow W_o^T.$$

The observer design problem is the *dual* of the state feedback design problem. Using the results of Theorem 7.3, we get the following theorem on observer design.

**Theorem 8.2** (Observer design by eigenvalue assignment). *Consider the system given by*

$$\frac{dx}{dt} = Ax + Bu, \quad y = Cx, \quad (8.9)$$

*with one input and one output. Let  $\lambda(s) = s^n + a_1s^{n-1} + \dots + a_{n-1}s + a_n$  be the characteristic polynomial for  $A$ . If the system is observable, then the dynamical system*

$$\frac{d\hat{x}}{dt} = A\hat{x} + Bu + L(y - C\hat{x}) \quad (8.10)$$

*is an observer for the system, with  $L$  chosen as*

$$L = W_o^{-1} \tilde{W}_o \begin{pmatrix} p_1 - a_1 \\ p_2 - a_2 \\ \vdots \\ p_n - a_n \end{pmatrix} \quad (8.11)$$

*and the matrices  $W_o$  and  $\tilde{W}_o$  given by*

$$W_o = \begin{pmatrix} C \\ CA \\ \vdots \\ CA^{n-1} \end{pmatrix}, \quad \tilde{W}_o = \begin{pmatrix} 1 & 0 & 0 & \dots & 0 & 0 \\ a_1 & 1 & 0 & \dots & 0 & 0 \\ a_2 & a_1 & 1 & & 0 & 0 \\ \vdots & \vdots & & \ddots & \vdots & \\ a_{n-2} & a_{n-3} & a_{n-4} & & 1 & 0 \\ a_{n-1} & a_{n-2} & a_{n-3} & \dots & a_1 & 1 \end{pmatrix}^{-1}.$$

*The resulting observer error  $\tilde{x} = x - \hat{x}$  is governed by a differential equation having the characteristic polynomial*

$$p(s) = s^n + p_1s^{n-1} + \dots + p_n.$$

The dynamical system (8.10) is called an *observer* for (the states of) the system (8.9) because it will generate an approximation of the states of the system from its inputs and outputs. This form of an observer is a much more useful form than the one given by pure differentiation in equation (8.3).

### Example 8.2 Compartment model

Consider the compartment model in Example 8.1, which is characterized by the matrices

$$A = \begin{pmatrix} -k_0 - k_1 & k_1 \\ k_2 & -k_2 \end{pmatrix}, \quad B = \begin{pmatrix} b_0 \\ 0 \end{pmatrix}, \quad C = \begin{pmatrix} 1 & 0 \end{pmatrix}.$$

The observability matrix was computed in Example 8.1, where we concluded that the system was observable if  $k_1 \neq 0$ . The dynamics matrix has the characteristic polynomial

$$\lambda(s) = \det \begin{pmatrix} s + k_0 + k_1 & -k_1 \\ -k_2 & s + k_2 \end{pmatrix} = s^2 + (k_0 + k_1 + k_2)s + k_0k_2.$$

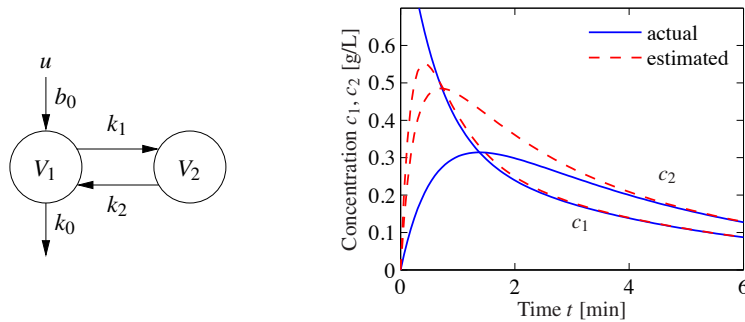

**Figure 8.4:** Observer for a two compartment system. A two compartment model is shown on the left. The observer measures the input concentration  $u$  and output concentration  $y = c_1$  to determine the compartment concentrations, shown on the right. The true concentrations are shown by solid lines and the estimates generated by the observer by dashed lines.

Let the desired characteristic polynomial of the observer be  $s^2 + p_1s + p_2$ , and equation (8.11) gives the observer gain

$$L = \begin{pmatrix} 1 & 0 \\ -k_0 - k_1 & k_1 \end{pmatrix}^{-1} \begin{pmatrix} 1 & 0 \\ k_0 + k_1 + k_2 & 1 \end{pmatrix}^{-1} \begin{pmatrix} p_1 - k_0 - k_1 - k_2 \\ p_2 - k_0k_2 \end{pmatrix} \\ = \begin{pmatrix} p_1 - k_0 - k_1 - k_2 \\ (p_2 - p_1k_2 + k_1k_2 + k_2^2)/k_1 \end{pmatrix}.$$

Notice that the observability condition  $k_1 \neq 0$  is essential. The behavior of the observer is illustrated by the simulation in Figure 8.4b. Notice how the observed concentrations approach the true concentrations.  $\nabla$

The observer is a dynamical system whose inputs are the process input  $u$  and the process output  $y$ . The rate of change of the estimate is composed of two terms. One term,  $A\hat{x} + Bu$ , is the rate of change computed from the model with  $\hat{x}$  substituted for  $x$ . The other term,  $L(y - \hat{y})$ , is proportional to the difference  $e = y - \hat{y}$  between measured output  $y$  and its estimate  $\hat{y} = C\hat{x}$ . The observer gain  $L$  is a matrix that tells how the error  $e$  is weighted and distributed among the states. The observer thus combines measurements with a dynamical model of the system. A block diagram of the observer is shown in Figure 8.5.

### Computing the Observer Gain

For simple low-order problems it is convenient to introduce the elements of the observer gain  $L$  as unknown parameters and solve for the values required to give the desired characteristic polynomial, as illustrated in the following example.

#### Example 8.3 Vehicle steering

The normalized linear model for vehicle steering derived in Examples 6.12 and 7.4 gives the following state space model dynamics relating lateral path deviation  $y$  to

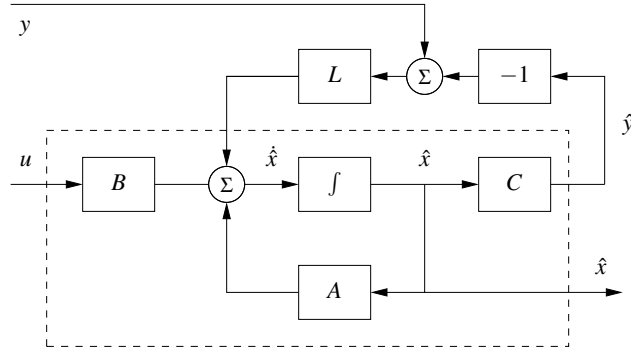

**Figure 8.5:** Block diagram of the observer. The observer takes the signals  $y$  and  $u$  as inputs and produces an estimate  $\hat{x}$ . Notice that the observer contains a copy of the process model that is driven by  $y - \hat{y}$  through the observer gain  $L$ .

steering angle  $u$ :

$$\frac{dx}{dt} = \begin{pmatrix} 0 & 1 \\ 0 & 0 \end{pmatrix} x + \begin{pmatrix} \gamma \\ 1 \end{pmatrix} u, \quad y = \begin{pmatrix} 1 & 0 \end{pmatrix} x. \quad (8.12)$$

Recall that the state  $x_1$  represents the lateral path deviation and that  $x_2$  represents the turning rate. We will now derive an observer that uses the system model to determine the turning rate from the measured path deviation.

The observability matrix is

$$W_o = \begin{pmatrix} 1 & 0 \\ 0 & 1 \end{pmatrix},$$

i.e., the identity matrix. The system is thus observable, and the eigenvalue assignment problem can be solved. We have

$$A - LC = \begin{pmatrix} -l_1 & 1 \\ -l_2 & 0 \end{pmatrix},$$

which has the characteristic polynomial

$$\det(sI - A + LC) = \det \begin{pmatrix} s + l_1 & -1 \\ l_2 & s \end{pmatrix} = s^2 + l_1 s + l_2.$$

Assuming that we want to have an observer with the characteristic polynomial

$$s^2 + p_1 s + p_2 = s^2 + 2\zeta_o \omega_o s + \omega_o^2,$$

the observer gains should be chosen as

$$l_1 = p_1 = 2\zeta_o \omega_o, \quad l_2 = p_2 = \omega_o^2.$$

The observer is then

$$\frac{d\hat{x}}{dt} = A\hat{x} + Bu + L(y - C\hat{x}) = \begin{pmatrix} 0 & 1 \\ 0 & 0 \end{pmatrix} \hat{x} + \begin{pmatrix} \gamma \\ 1 \end{pmatrix} u + \begin{pmatrix} l_1 \\ l_2 \end{pmatrix} (y - \hat{x}_1).$$

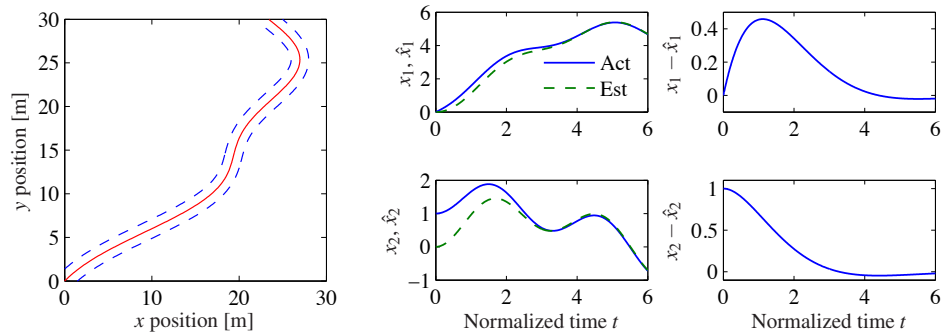

**Figure 8.6:** Simulation of an observer for a vehicle driving on a curvy road (left). The observer has an initial velocity error. The plots on the middle show the lateral deviation  $x_1$ , the lateral velocity  $x_2$  by solid lines and their estimates  $\hat{x}_1$  and  $\hat{x}_2$  by dashed lines. The plots on the right show the estimation errors.

A simulation of the observer for a vehicle driving on a curvy road is simulated in Figure 8.6. The vehicle length is the time unit in the normalized model. The figure shows that the observer error settles in about 3 vehicle lengths.  $\nabla$

For systems of high order we have to use numerical calculations. The duality between the design of a state feedback and the design of an observer means that the computer algorithms for state feedback can also be used for the observer design; we simply use the transpose of the dynamics matrix and the output matrix. The MATLAB command `acker`, which essentially is a direct implementation of the calculations given in Theorem 8.2, can be used for systems with one output. The MATLAB command `place` can be used for systems with many outputs. It is also better conditioned numerically.

### 8.3 Control Using Estimated State

In this section we will consider a state space system of the form

$$\frac{dx}{dt} = Ax + Bu, \quad y = Cx. \quad (8.13)$$

Notice that we have assumed that there is no direct term in the system ( $D = 0$ ). This is often a realistic assumption. The presence of a direct term in combination with a controller having proportional action creates an algebraic loop, which will be discussed in Section 9.4. The problem can be solved even if there is a direct term, but the calculations are more complicated.

We wish to design a feedback controller for the system where only the output is measured. As before, we will assume that  $u$  and  $y$  are scalars. We also assume that the system is reachable and observable. In Chapter 7 we found a feedback of the form

$$u = -Kx + k_r r$$

for the case that all states could be measured, and in Section 8.2 we developed an observer that can generate estimates of the state  $\hat{x}$  based on inputs and outputs. In this section we will combine the ideas of these sections to find a feedback that gives desired closed loop eigenvalues for systems where only outputs are available for feedback.

If all states are not measurable, it seems reasonable to try the feedback

$$u = -K\hat{x} + k_r r, \quad (8.14)$$

where  $\hat{x}$  is the output of an observer of the state, i.e.,

$$\frac{d\hat{x}}{dt} = A\hat{x} + Bu + L(y - C\hat{x}). \quad (8.15)$$

It is not clear that such a combination will have the desired effect. To explore this, note that since the system (8.13) and the observer (8.15) are both of state dimension  $n$ , the closed loop system has state dimension  $2n$  with state  $(x, \hat{x})$ . The evolution of the states is described by equations (8.13)–(8.15). To analyze the closed loop system, we change coordinates and replace the estimated state variable  $\hat{x}$  by the estimation error

$$\tilde{x} = x - \hat{x}. \quad (8.16)$$

Subtraction of equation (8.15) from equation (8.13) gives

$$\frac{d\tilde{x}}{dt} = Ax - A\hat{x} - L(Cx - C\hat{x}) = A\tilde{x} - LC\tilde{x} = (A - LC)\tilde{x}.$$

Returning to the process dynamics, introducing  $u$  from equation (8.14) into equation (8.13) and using equation (8.16) to eliminate  $\hat{x}$  gives

$$\begin{aligned} \frac{dx}{dt} &= Ax + Bu = Ax - BK\hat{x} + Bk_r r = Ax - BK(x - \tilde{x}) + Bk_r r \\ &= (A - BK)x + BK\tilde{x} + Bk_r r. \end{aligned}$$

The closed loop system is thus governed by

$$\frac{d}{dt} \begin{pmatrix} x \\ \tilde{x} \end{pmatrix} = \begin{pmatrix} A - BK & BK \\ 0 & A - LC \end{pmatrix} \begin{pmatrix} x \\ \tilde{x} \end{pmatrix} + \begin{pmatrix} Bk_r \\ 0 \end{pmatrix} r. \quad (8.17)$$

Notice that the state  $\tilde{x}$ , representing the observer error, is not affected by the reference signal  $r$ . This is desirable since we do not want the reference signal to generate observer errors.

Since the dynamics matrix is block diagonal, we find that the characteristic polynomial of the closed loop system is

$$\lambda(s) = \det(sI - A + BK) \det(sI - A + LC).$$

This polynomial is a product of two terms: the characteristic polynomial of the closed loop system obtained with state feedback and the characteristic polynomial of the observer error. The feedback (8.14) that was motivated heuristically thus provides a neat solution to the eigenvalue assignment problem. The result is summarized as follows.

**Theorem 8.3** (Eigenvalue assignment by output feedback). *Consider the system*

$$\frac{dx}{dt} = Ax + Bu, \quad y = Cx.$$

The controller described by

$$\begin{aligned} \frac{d\hat{x}}{dt} &= A\hat{x} + Bu + L(y - C\hat{x}) = (A - BK - LC)\hat{x} + Bk_r r + Ly, \\ u &= -K\hat{x} + k_r r \end{aligned}$$

gives a closed loop system with the characteristic polynomial

$$\lambda(s) = \det(sI - A + BK) \det(sI - A + LC).$$

This polynomial can be assigned arbitrary roots if the system is reachable and observable.

The controller has a strong intuitive appeal: it can be thought of as being composed of two parts: state feedback and an observer. The controller is now a dynamical system with internal state dynamics generated by the observer. The control action makes use of feedback from the estimated states  $\hat{x}$ . The feedback gain  $K$  can be computed as if all state variables can be measured, and it depends on only  $A$  and  $B$ . The observer gain  $L$  depends on only  $A$  and  $C$ . The property that the eigenvalue assignment for output feedback can be separated into an eigenvalue assignment for a state feedback and an observer is called the *separation principle*.

A block diagram of the controller is shown in Figure 8.7. Notice that the controller contains a dynamical model of the plant. This is called the *internal model principle*: the controller contains a model of the process being controlled.

#### Example 8.4 Vehicle steering

Consider again the normalized linear model for vehicle steering in Example 7.4. The dynamics relating the steering angle  $u$  to the lateral path deviation  $y$  is given by the state space model (8.12). Combining the state feedback derived in Example 7.4 with the observer determined in Example 8.3, we find that the controller is given by

$$\begin{aligned} \frac{d\hat{x}}{dt} &= A\hat{x} + Bu + L(y - C\hat{x}) = \begin{pmatrix} 0 & 1 \\ 0 & 0 \end{pmatrix} \hat{x} + \begin{pmatrix} \gamma \\ 1 \end{pmatrix} u + \begin{pmatrix} l_1 \\ l_2 \end{pmatrix} (y - \hat{x}_1), \\ u &= -K\hat{x} + k_r r = k_1(r - \hat{x}_1) - k_2\hat{x}_2. \end{aligned}$$

Elimination of the variable  $u$  gives

$$\begin{aligned} \frac{d\hat{x}}{dt} &= (A - BK - LC)\hat{x} + Ly + Bk_r r \\ &= \begin{pmatrix} -l_1 - \gamma k_1 & 1 - \gamma k_2 \\ -k_1 - l_2 & -k_2 \end{pmatrix} \hat{x} + \begin{pmatrix} l_1 \\ l_2 \end{pmatrix} y + \begin{pmatrix} \gamma \\ 1 \end{pmatrix} k_1 r, \end{aligned}$$

where we have set  $k_r = k_1$  as described in Example 7.4. The controller is a dynamical system of second order, with two inputs  $y$  and  $r$  and one output  $u$ . Figure 8.8

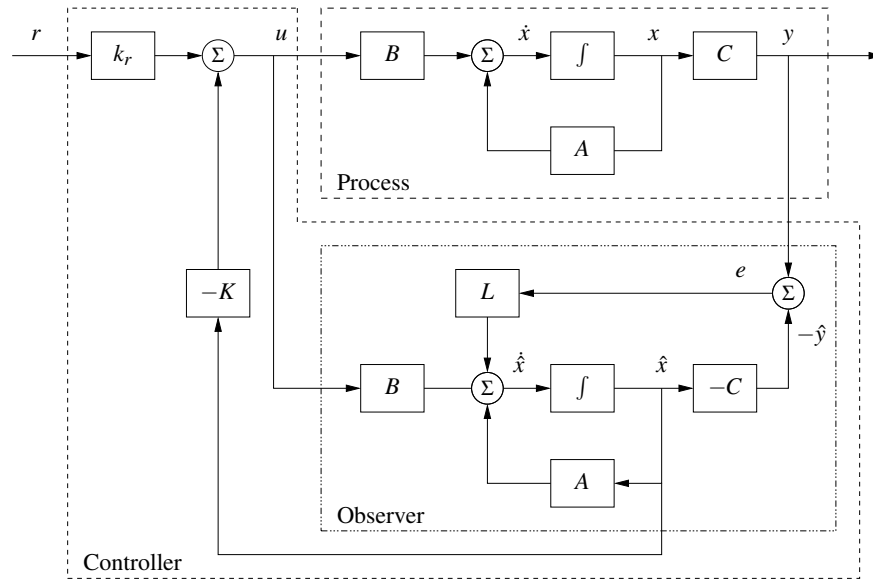

**Figure 8.7:** Block diagram of an observer-based control system. The observer uses the measured output  $y$  and the input  $u$  to construct an estimate of the state. This estimate is used by a state feedback controller to generate the corrective input. The controller consists of the observer and the state feedback; the observer is identical to that in Figure 8.5.

shows a simulation of the system when the vehicle is driven along a curvy road. Since we are using a normalized model, the length unit is the vehicle length and the time unit is the time it takes to travel one vehicle length. The estimator is initialized with all states equal to zero but the real system has an initial velocity of 0.5. The figures show that the estimates converge quickly to their true values. The vehicle tracks the desired path, which is in the middle of the road, but there are errors because the road is irregular. The tracking error can be improved by introducing feedforward (Section 8.5).  $\nabla$



## 8.4 Kalman Filtering

One of the principal uses of observers in practice is to estimate the state of a system in the presence of *noisy* measurements. We have not yet treated noise in our analysis, and a full treatment of stochastic dynamical systems is beyond the scope of this text. In this section, we present a brief introduction to the use of stochastic systems analysis for constructing observers. We work primarily in discrete time to avoid some of the complications associated with continuous-time random processes and to keep the mathematical prerequisites to a minimum. This section assumes basic knowledge of random variables and stochastic processes; see Kumar and Varaiya [KV86] or Åström [Åst06] for the required material.



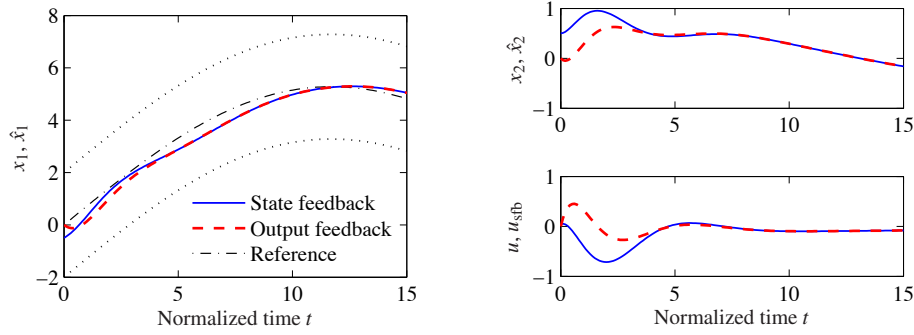

**Figure 8.8:** Simulation of a vehicle driving on a curvy road with a controller based on state feedback and an observer. The left plot shows the lane boundaries (dotted), the vehicle position (solid) and its estimate (dashed), the upper right plot shows the velocity (solid) and its estimate (dashed), and the lower right plot shows the control signal using state feedback (solid) and the control signal using the estimated state (dashed).

Consider a discrete-time linear system with dynamics

$$x[k+1] = Ax[k] + Bu[k] + Fv[k], \quad y[k] = Cx[k] + w[k], \quad (8.18)$$

where  $v[k]$  and  $w[k]$  are Gaussian white noise processes satisfying

$$\begin{aligned} \mathbb{E}(v[k]) &= 0, & \mathbb{E}(w[k]) &= 0, \\ \mathbb{E}(v[k]v^T[j]) &= \begin{cases} 0 & k \neq j \\ R_v & k = j, \end{cases} & \mathbb{E}(w[k]w^T[j]) &= \begin{cases} 0 & k \neq j \\ R_w & k = j, \end{cases} \\ \mathbb{E}(v[k]w^T[j]) &= 0. \end{aligned} \quad (8.19)$$

$\mathbb{E}(v[k])$  represents the expected value of  $v[k]$  and  $\mathbb{E}(v[k]v^T[j])$  is the correlation matrix. The matrices  $R_v$  and  $R_w$  are the covariance matrices for the process disturbance  $v$  and measurement noise  $w$ . We assume that the initial condition is also modeled as a Gaussian random variable with

$$\mathbb{E}(x[0]) = x_0, \quad \mathbb{E}(x[0]x^T[0]) = P_0. \quad (8.20)$$

We would like to find an estimate  $\hat{x}[k]$  that minimizes the mean square error  $\mathbb{E}((x[k] - \hat{x}[k])(x[k] - \hat{x}[k])^T)$  given the measurements  $\{y(\tau) : 0 \leq \tau \leq t\}$ . We consider an observer in the same basic form as derived previously:

$$\hat{x}[k+1] = A\hat{x}[k] + Bu[k] + L[k](y[k] - C\hat{x}[k]). \quad (8.21)$$

The following theorem summarizes the main result.

**Theorem 8.4** (Kalman, 1961). *Consider a random process  $x[k]$  with dynamics given by equation (8.18) and noise processes and initial conditions described by equations (8.19) and (8.20). The observer gain  $L$  that minimizes the mean square error is given by*

$$L[k] = AP[k]C^T(R_w + CP[k]C^T)^{-1},$$

where

$$\begin{aligned} P[k+1] &= (A-LC)P[k](A-LC)^T + FR_vF^T + LR_wL^T \\ P_0 &= \mathbb{E}(x[0]x^T[0]). \end{aligned} \quad (8.22)$$

Before we prove this result, we reflect on its form and function. First, note that the Kalman filter has the form of a *recursive* filter: given mean square error  $P[k] = \mathbb{E}((x[k] - \hat{x}[k])(x[k] - \hat{x}[k])^T)$  at time  $k$ , we can compute how the estimate and error *change*. Thus we do not need to keep track of old values of the output. Furthermore, the Kalman filter gives the estimate  $\hat{x}[k]$  and the error covariance  $P[k]$ , so we can see how reliable the estimate is. It can also be shown that the Kalman filter extracts the maximum possible information about output data. If we form the residual between the measured output and the estimated output,

$$e[k] = y[k] - C\hat{x}[k],$$

we can show that for the Kalman filter the correlation matrix is

$$R_e(j, k) = \mathbb{E}(e[j]e^T[k]) = W[k]\delta_{jk}, \quad \delta_{jk} = \begin{cases} 1 & j = k \\ 0 & j \neq k. \end{cases}$$

In other words, the error is a white noise process, so there is no remaining dynamic information content in the error.

The Kalman filter is extremely versatile and can be used even if the process, noise or disturbances are time-varying. When the system is time-invariant and if  $P[k]$  converges, then the observer gain is constant:

$$L = APC^T(R_w + CPC^T)^{-1},$$

where  $P$  satisfies

$$P = APA^T + FR_vF^T - APC^T(R_w + CPC^T)^{-1}CPA^T.$$

We see that the optimal gain depends on both the process noise and the measurement noise, but in a nontrivial way. Like the use of LQR to choose state feedback gains, the Kalman filter permits a systematic derivation of the observer gains given a description of the noise processes. The solution for the constant gain case is solved by the `dlqe` command in MATLAB.

*Proof of theorem.* We wish to minimize the mean square of the error  $\mathbb{E}((x[k] - \hat{x}[k])(x[k] - \hat{x}[k])^T)$ . We will define this quantity as  $P[k]$  and then show that it satisfies the recursion given in equation (8.22). By definition,

$$\begin{aligned} P[k+1] &= \mathbb{E}((x[k+1] - \hat{x}[k+1])(x[k+1] - \hat{x}[k+1])^T) \\ &= (A-LC)P[k](A-LC)^T + FR_vF^T + LR_wL^T \\ &= AP[k]A^T + FR_vF^T - AP[k]C^TL^T - LCP[k]A^T \\ &\quad + L(R_w + CP[k]C^T)L^T. \end{aligned}$$

Letting  $R_\varepsilon = (R_w + CP[k]C^T)$ , we have

$$\begin{aligned} P[k+1] &= AP[k]A^T + FR_vF^T - AP[k]C^T L^T - LCP[k]A^T + LR_\varepsilon L^T \\ &= AP[k]A^T + FR_vF^T + (L - AP[k]C^T R_\varepsilon^{-1})R_\varepsilon(L - AP[k]C^T R_\varepsilon^{-1})^T \\ &\quad - AP[k]C^T R_\varepsilon^{-1}CP^T[k]A^T. \end{aligned}$$

To minimize this expression, we choose  $L = AP[k]C^T R_\varepsilon^{-1}$ , and the theorem is proved.  $\square$

The Kalman filter can also be applied to continuous-time stochastic processes. The mathematical derivation of this result requires more sophisticated tools, but the final form of the estimator is relatively straightforward.

Consider a continuous stochastic system

$$\begin{aligned} \frac{dx}{dt} &= Ax + Bu + Fv, & \mathbb{E}(v(s)v^T(t)) &= R_v(t)\delta(t-s), \\ y &= Cx + w, & \mathbb{E}(w(s)w^T(t)) &= R_w(t)\delta(t-s), \end{aligned}$$

where  $\delta(\tau)$  is the unit impulse function. Assume that the disturbance  $v$  and noise  $w$  are zero mean and Gaussian (but not necessarily time-invariant):

$$\text{pdf}(v) = \frac{1}{\sqrt{n/2\pi}\sqrt{\det R_v}} e^{-\frac{1}{2}v^T R_v^{-1}v}, \quad \text{pdf}(w) = \frac{1}{\sqrt{n/2\pi}\sqrt{\det R_w}} e^{-\frac{1}{2}w^T R_w^{-1}w}.$$

We wish to find the estimate  $\hat{x}(t)$  that minimizes the mean square error  $\mathbb{E}((x(t) - \hat{x}(t))(x(t) - \hat{x}(t))^T)$  given  $\{y(\tau) : 0 \leq \tau \leq t\}$ .

**Theorem 8.5** (Kalman–Bucy, 1961). *The optimal estimator has the form of a linear observer*

$$\frac{d\hat{x}}{dt} = A\hat{x} + Bu + L(y - C\hat{x}),$$

where  $L(t) = P(t)C^T R_w^{-1}$  and  $P(t) = \mathbb{E}((x(t) - \hat{x}(t))(x(t) - \hat{x}(t))^T)$  and satisfies

$$\frac{dP}{dt} = AP + PA^T - PC^T R_w^{-1}(t)CP + FR_v(t)F^T, \quad P[0] = \mathbb{E}(x[0]x^T[0]).$$

As in the discrete case, when the system is time-invariant and if  $P(t)$  converges, the observer gain is constant:

$$L = PC^T R_w^{-1} \quad \text{where} \quad AP + PA^T - PC^T R_w^{-1}CP + FR_v F^T = 0.$$

The second equation is the *algebraic Riccati equation*.

### Example 8.5 Vectored thrust aircraft

We consider the lateral dynamics of the system, consisting of the subsystems whose states are given by  $z = (x, \theta, \dot{x}, \dot{\theta})$ . The dynamics of the system can be ob-

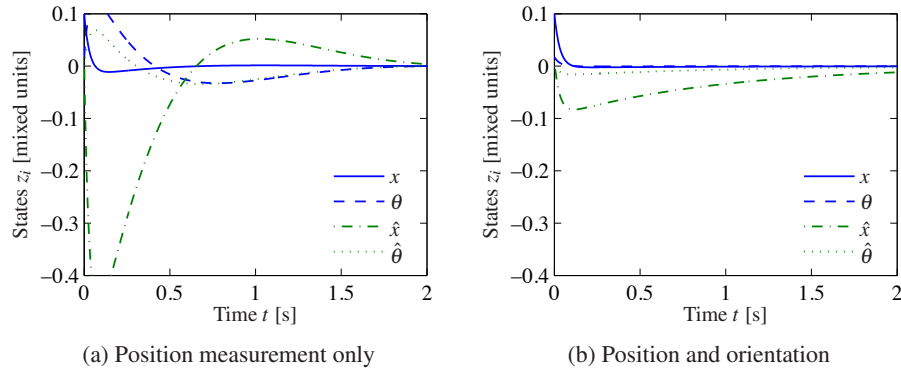

**Figure 8.9:** Kalman filter design for a vectored thrust aircraft. In the first design (a) only the lateral position of the aircraft is measured. Adding a direct measurement of the roll angle produces a much better observer (b). The initial condition for both simulations is  $(0.1, 0.0175, 0.01, 0)$  and the controller gains are .

tained from Example 7.8 by extracting only the relevant states and outputs, giving

$$A = \begin{pmatrix} 0 & 0 & 1 & 0 \\ 0 & 0 & 0 & 1 \\ 0 & -g & -c/m & 0 \\ 0 & 0 & 0 & 0 \end{pmatrix}, \quad B = \begin{pmatrix} 0 \\ 0 \\ 0 \\ r/J \end{pmatrix}, \quad C = \begin{pmatrix} 0 & 0 & 0 & 1 \end{pmatrix}.$$

To design a Kalman filter for the system, we must include a description of the process disturbances and the sensor noise. We thus augment the system to have the form

$$\frac{dz}{dt} = Az + Bu + Fv, \quad y = Cz + w,$$

where  $F$  represents the structure of the disturbances (including the effects of nonlinearities that we have ignored in the linearization),  $v$  represents the disturbance source (modeled as zero mean, Gaussian white noise) and  $w$  represents that measurement noise (also zero mean, Gaussian and white).

For this example, we choose  $F$  as the identity matrix and choose disturbances  $v_i$ ,  $i = 1, \dots, n$ , to be independent random variables with covariance given by  $R_{ii} = 0.1$ ,  $R_{ij} = 0$ ,  $i \neq j$ . The sensor noise is a single random variable which we model as white noise having covariance  $R_w = 10^{-4}$ . Using the same parameters as before, the resulting Kalman gain is given by

$$L = \begin{pmatrix} 37.0 \\ -46.9 \\ 185 \\ -31.6 \end{pmatrix}.$$

The performance of the estimator is shown in Figure 8.9a. We see that while the estimator converges to the system state, it contains significant overshoot in the

state estimate, which can lead to poor performance in a closed loop setting.

To improve the performance of the estimator, we explore the impact of adding a new output measurement. Suppose that instead of measuring just the output position  $x$ , we also measure the orientation of the aircraft  $\theta$ . The output becomes

$$y = \begin{pmatrix} 1 & 0 & 0 & 0 \\ 0 & 1 & 0 & 0 \end{pmatrix} z + \begin{pmatrix} w_1 \\ w_2 \end{pmatrix},$$

and if we assume that  $w_1$  and  $w_2$  are independent white noise sources each with covariance  $R_{w_i} = 10^{-4}$ , then the optimal estimator gain matrix becomes

$$L = \begin{pmatrix} 32.6 & -0.150 \\ -0.150 & 32.6 \\ 32.7 & -9.79 \\ -0.0033 & 31.6 \end{pmatrix}.$$

These gains provide good immunity to noise and high performance, as illustrated in Figure 8.9b. Note that the system trajectories are different in (a) and (b) since different estimates are used in each case (this difference is most noticeable in the  $\theta$  trajectory). ▽

## 8.5 A General Controller Structure

State estimators and state feedback are important components of a controller. In this section, we will add feedforward to arrive at a general controller structure that appears in many places in control theory and is the heart of most modern control systems. We will also briefly sketch how computers can be used to implement a controller based on output feedback.

### Feedforward

In this chapter and the previous one we have emphasized feedback as a mechanism for minimizing tracking error; reference values were introduced simply by adding them to the state feedback through a gain  $k_r$ . A more sophisticated way of doing this is shown by the block diagram in Figure 8.10, where the controller consists of three parts: an observer that computes estimates of the states based on a model and measured process inputs and outputs, a state feedback, and a trajectory generator that generates the desired behavior of all states  $x_d$  and a feedforward signal  $u_{ff}$ . Under the ideal conditions of no disturbances and no modeling errors the signal  $u_{ff}$  generates the desired behavior  $x_d$  when applied to the process. The signals  $x_d$  and  $u_{ff}$  can be generated from the reference input  $r$  by making use of the model of the process dynamics.

To get some insight into the behavior of the system, we assume that there are no disturbances and that the system is in equilibrium with a constant reference signal and with the observer state  $\hat{x}$  equal to the process state  $x$ . When the reference signal is changed, the signals  $u_{ff}$  and  $x_d$  will change. The observer tracks the state

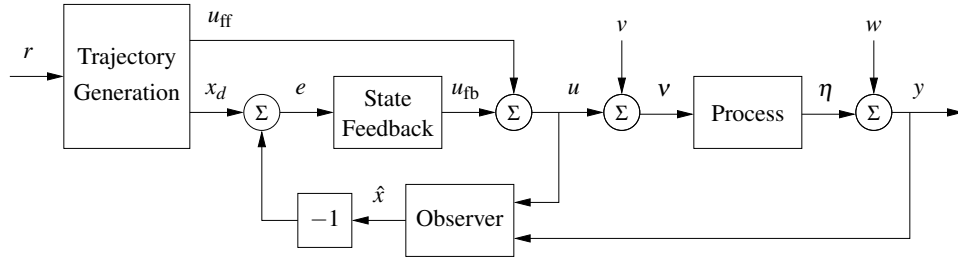

**Figure 8.10:** Block diagram of a controller based on a structure with two degrees of freedom which combines feedback and feedforward. The controller consists of a trajectory generator, state feedback and an observer. The trajectory generation subsystem computes a feedforward command  $u_{\text{ff}}$  along with the desired state  $x_d$ . The state feedback controller uses the estimated state and desired state to compute a corrective input  $u_{\text{fb}}$ .

perfectly because the initial state was correct. The estimated state  $\hat{x}$  is thus equal to the desired state  $x_d$ , and the feedback signal  $u_{\text{fb}} = K(x_d - \hat{x})$  will also be zero. All action is thus created by the signals from the trajectory generator. If there are some disturbances or some modeling errors, the feedback signal will attempt to correct the situation.

This controller is said to have *two degrees of freedom* because the responses to command signals and disturbances are decoupled. Disturbance responses are governed by the observer and the state feedback, while the response to command signals is governed by the trajectory generator (feedforward).

For an analytic description we start with the full nonlinear dynamics of the process

$$\frac{dx}{dt} = f(x, u), \quad y = h(x, u). \quad (8.23)$$

Assume that the trajectory generator is able to compute a desired trajectory  $(x_d, u_{\text{ff}})$  that satisfies the dynamics (8.23) and satisfies  $r = h(x_d, u_{\text{ff}})$ . To design the controller, we construct the error system. Let  $z = x - x_d$  and  $v = u - u_{\text{ff}}$  and compute the dynamics for the error:

$$\begin{aligned} \dot{z} &= \dot{x} - \dot{x}_d = f(x, u) - f(x_d, u_{\text{ff}}) \\ &= f(z + x_d, v + u_{\text{ff}}) - f(x_d, u_{\text{ff}}) =: F(z, v, x_d(t), u_{\text{ff}}(t)). \end{aligned}$$

In general, this system is time-varying. Note that  $z$  corresponds to  $-e$  in Figure 8.10 due to the convention of using negative feedback in the block diagram.

For trajectory tracking, we can assume that  $e$  is small (if our controller is doing a good job), and so we can linearize around  $z = 0$ :

$$\frac{dz}{dt} \approx A(t)z + B(t)v, \quad A(t) = \left. \frac{\partial F}{\partial z} \right|_{(x_d(t), u_{\text{ff}}(t))}, \quad B(t) = \left. \frac{\partial F}{\partial v} \right|_{(x_d(t), u_{\text{ff}}(t))}.$$

It is often the case that  $A(t)$  and  $B(t)$  depend only on  $x_d$ , in which case it is convenient to write  $A(t) = A(x_d)$  and  $B(t) = B(x_d)$ .

Assume now that  $x_d$  and  $u_{\text{ff}}$  are either constant or slowly varying (with respect

to the performance criterion). This allows us to consider just the (constant) linear system given by  $(A(x_d), B(x_d))$ . If we design a state feedback controller  $K(x_d)$  for each  $x_d$ , then we can regulate the system using the feedback

$$v = -K(x_d)z.$$

Substituting back the definitions of  $z$  and  $v$ , our controller becomes

$$u = -K(x_d)(x - x_d) + u_{\text{ff}}.$$

This form of controller is called a *gain scheduled* linear controller with *feedforward*  $u_{\text{ff}}$ .

Finally, we consider the observer. The full nonlinear dynamics can be used for the prediction portion of the observer and the linearized system for the correction term:

$$\frac{d\hat{x}}{dt} = f(\hat{x}, u) + L(\hat{x})(y - h(\hat{x}, u)),$$

where  $L(\hat{x})$  is the observer gain obtained by linearizing the system around the currently estimated state. This form of the observer is known as an *extended Kalman filter* and has proved to be a very effective means of estimating the state of a nonlinear system.

There are many ways to generate the feedforward signal, and there are also many different ways to compute the feedback gain  $K$  and the observer gain  $L$ . Note that once again the internal model principle applies: the controller contains a model of the system to be controlled through the observer.

### Example 8.6 Vehicle steering

To illustrate how we can use a two degree-of-freedom design to improve the performance of the system, consider the problem of steering a car to change lanes on a road, as illustrated in Figure 8.11a.

We use the non-normalized form of the dynamics, which were derived in Example 3.10. Using the center of the rear wheels as the reference ( $\alpha = 0$ ), the dynamics can be written as

$$\frac{dx}{dt} = \cos \theta v, \quad \frac{dy}{dt} = \sin \theta v, \quad \frac{d\theta}{dt} = \frac{v}{b} \tan \delta,$$

where  $v$  is the forward velocity of the vehicle,  $\theta$  is the heading angle and  $\delta$  is the steering angle. To generate a trajectory for the system, we note that we can solve for the states and inputs of the system given  $x(t)$ ,  $y(t)$  by solving the following sets of equations:

$$\begin{aligned} \dot{x} &= v \cos \theta, & \ddot{x} &= \dot{v} \cos \theta - v \dot{\theta} \sin \theta, \\ \dot{y} &= v \sin \theta, & \ddot{y} &= \dot{v} \sin \theta + v \dot{\theta} \cos \theta, \\ \dot{\theta} &= (v/b) \tan \delta. \end{aligned} \tag{8.24}$$

This set of five equations has five unknowns ( $\theta$ ,  $\dot{\theta}$ ,  $v$ ,  $\dot{v}$  and  $\delta$ ) that can be solved using trigonometry and linear algebra given the path variables  $x(t)$ ,  $y(t)$  and their time derivatives. It follows that we can compute a feasible state trajectory for the

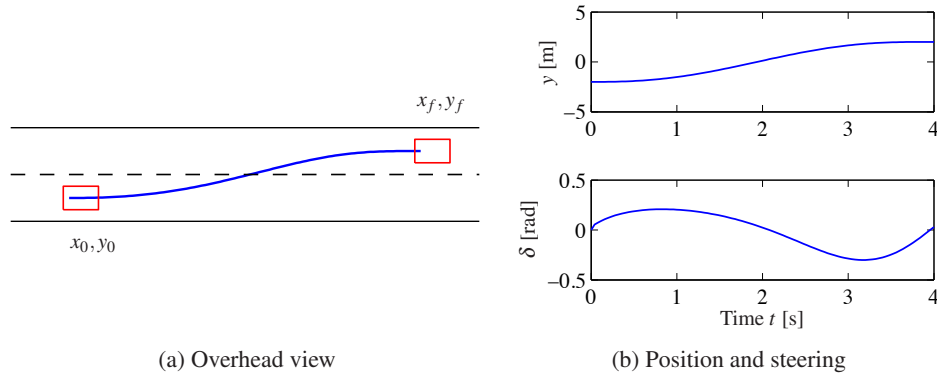

**Figure 8.11:** Trajectory generation for changing lanes. We wish to change from the left lane to the right lane over a distance of 30 m in 4 s. The planned trajectory in the  $xy$  plane is shown in (a) and the lateral position  $y$  and the steering angle  $\delta$  over the maneuver time interval are shown in (b).

system given any path  $x(t)$ ,  $y(t)$ . (This special property of a system is known as *differential flatness* [FLMR92, FLMR95].)

To find a trajectory from an initial state  $(x_0, y_0, \theta_0)$  to a final state  $(x_f, y_f, \theta_f)$  at a time  $T$ , we look for a path  $x(t), y(t)$  that satisfies

$$\begin{aligned}
 x(0) &= x_0, & x(T) &= x_f, \\
 y(0) &= y_0, & y(T) &= y_f, \\
 \dot{x}(0) \sin \theta_0 - \dot{y}(0) \cos \theta_0 &= 0, & \dot{x}(T) \sin \theta_f - \dot{y}(T) \cos \theta_f &= 0, \\
 \dot{y}(0) \sin \theta_0 + \dot{x}(0) \cos \theta_0 &= v_0, & \dot{y}(T) \sin \theta_f + \dot{x}(T) \cos \theta_f &= v_f.
 \end{aligned} \tag{8.25}$$

One such trajectory can be found by choosing  $x(t)$  and  $y(t)$  to have the form

$$x_d(t) = \alpha_0 + \alpha_1 t + \alpha_2 t^2 + \alpha_3 t^3, \quad y_d(t) = \beta_0 + \beta_1 t + \beta_2 t^2 + \beta_3 t^3.$$

Substituting these equations into equation (8.25), we are left with a set of linear equations that can be solved for  $\alpha_i, \beta_i$ ,  $i = 0, 1, 2, 3$ . This gives a feasible trajectory for the system by using equation (8.24) to solve for  $\theta_d$ ,  $v_d$  and  $\delta_d$ .

Figure 8.11b shows a sample trajectory generated by a set of higher-order equations that also set the initial and final steering angle to zero. Notice that the feedforward input is quite different from 0, allowing the controller to command a steering angle that executes the turn in the absence of errors.  $\nabla$



### Kalman's Decomposition of a Linear System

In this chapter and the previous one we have seen that two fundamental properties of a linear input/output system are reachability and observability. It turns out that these two properties can be used to classify the dynamics of a system. The key result is Kalman's decomposition theorem, which says that a linear system can be



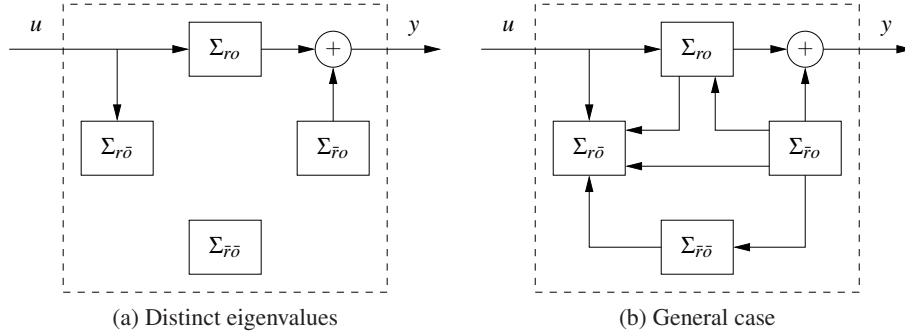

**Figure 8.12:** Kalman's decomposition of a linear system. The decomposition in (a) is for a system with distinct eigenvalues and the one in (b) is the general case. The system is broken into four subsystems, representing the various combinations of reachable and observable states. The input/output relationship only depends on the subset of states that are both reachable and observable.

divided into four subsystems:  $\Sigma_{ro}$  which is reachable and observable,  $\Sigma_{r\bar{o}}$  which is reachable but not observable,  $\Sigma_{\bar{r}o}$  which is not reachable but is observable and  $\Sigma_{\bar{r}\bar{o}}$  which is neither reachable nor observable.

We will first consider this in the special case of systems where the matrix  $A$  has distinct eigenvalues. In this case we can find a set of coordinates such that the  $A$  matrix is diagonal and, with some additional reordering of the states, the system can be written as

$$\frac{dx}{dt} = \begin{pmatrix} A_{ro} & 0 & 0 & 0 \\ 0 & A_{r\bar{o}} & 0 & 0 \\ 0 & 0 & A_{\bar{r}o} & 0 \\ 0 & 0 & 0 & A_{\bar{r}\bar{o}} \end{pmatrix} x + \begin{pmatrix} B_{ro} \\ B_{r\bar{o}} \\ 0 \\ 0 \end{pmatrix} u, \quad (8.26)$$

$$y = \begin{pmatrix} C_{ro} & 0 & C_{\bar{r}o} & 0 \end{pmatrix} x + Du.$$

All states  $x_k$  such that  $B_k \neq 0$  are reachable, and all states such that  $C_k \neq 0$  are observable. If we set the initial state to zero (or equivalently look at the steady-state response if  $A$  is stable), the states given by  $x_{\bar{r}o}$  and  $x_{\bar{r}\bar{o}}$  will be zero and  $x_{r\bar{o}}$  does not affect the output. Hence the output  $y$  can be determined from the system

$$\frac{dx_{ro}}{dt} = A_{ro}x_{ro} + B_{ro}u, \quad y = C_{ro}x_{ro} + Du.$$

Thus from the input/output point of view, it is only the reachable and observable dynamics that matter. A block diagram of the system illustrating this property is given in Figure 8.12a.

The general case of the Kalman decomposition is more complicated and requires some additional linear algebra; see the original paper by Kalman, Ho and Narendra [KHN63]. The key result is that the state space can still be decomposed into four parts, but there will be additional coupling so that the equations have the

form

$$\begin{aligned} \frac{dx}{dt} &= \begin{pmatrix} A_{ro} & 0 & * & 0 \\ * & A_{r\bar{o}} & * & * \\ 0 & 0 & A_{\bar{r}o} & 0 \\ 0 & 0 & * & A_{\bar{r}\bar{o}} \end{pmatrix} x + \begin{pmatrix} B_{ro} \\ B_{r\bar{o}} \\ 0 \\ 0 \end{pmatrix} u, \\ y &= \begin{pmatrix} C_{ro} & 0 & C_{\bar{r}o} & 0 \end{pmatrix} x, \end{aligned} \quad (8.27)$$

where \* denotes block matrices of appropriate dimensions. If  $x_{\bar{r}o}(0) = 0$  then the input/output response of the system is given by

$$\frac{dx_{ro}}{dt} = A_{ro}x_{ro} + B_{ro}u, \quad y = C_{ro}x_{ro} + Du, \quad (8.28)$$

which are the dynamics of the reachable and observable subsystem  $\Sigma_{ro}$ . A block diagram of the system is shown in Figure 8.12b.

The following example illustrates Kalman's decomposition.

### Example 8.7 System and controller with feedback from observer states

Consider the system

$$\frac{dx}{dt} = Ax + Bu, \quad y = Cx.$$

The following controller, based on feedback from the observer state, was given in Theorem 8.3:

$$\frac{d\hat{x}}{dt} = A\hat{x} + Bu + L(y - C\hat{x}), \quad u = -K\hat{x} + k_r r.$$

Introducing the states  $x$  and  $\tilde{x} = x - \hat{x}$ , the closed loop system can be written as

$$\frac{d}{dt} \begin{pmatrix} x \\ \tilde{x} \end{pmatrix} = \begin{pmatrix} A - BK & BK \\ 0 & A - LC \end{pmatrix} \begin{pmatrix} x \\ \tilde{x} \end{pmatrix} + \begin{pmatrix} Bk_r \\ 0 \end{pmatrix} r, \quad y = \begin{pmatrix} C & 0 \end{pmatrix} \begin{pmatrix} x \\ \tilde{x} \end{pmatrix},$$

which is a Kalman decomposition like the one shown in Figure 8.12b with only two subsystems  $\Sigma_{ro}$  and  $\Sigma_{\bar{r}o}$ . The subsystem  $\Sigma_{ro}$ , with state  $x$ , is reachable and observable, and the subsystem  $\Sigma_{\bar{r}o}$ , with state  $\tilde{x}$ , is not reachable but observable. It is natural that the state  $\tilde{x}$  is not reachable from the reference signal  $r$  because it would not make sense to design a system where changes in the command signal could generate observer errors. The relationship between the reference  $r$  and the output  $y$  is given by

$$\frac{dx}{dt} = (A - BK)x + Bk_r r, \quad y = Cx,$$

which is the same relationship as for a system with full state feedback.  $\nabla$

### Computer Implementation

The controllers obtained so far have been described by ordinary differential equations. They can be implemented directly using analog components, whether electronic circuits, hydraulic valves or other physical devices. Since in modern engi-

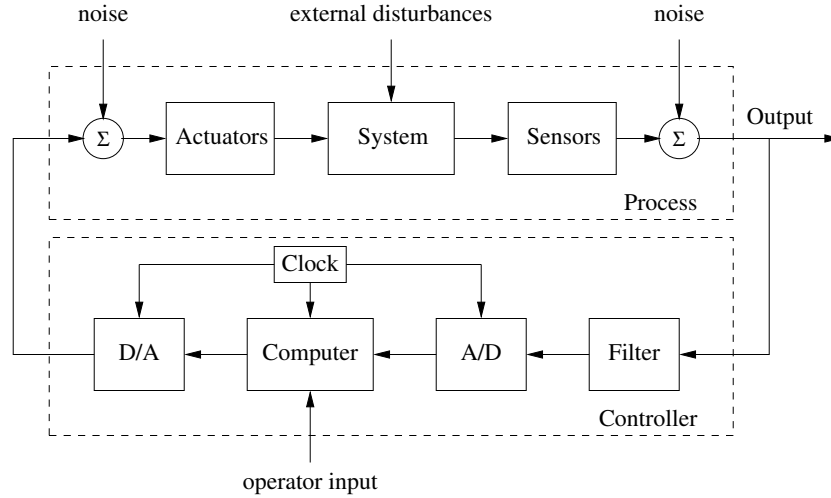

**Figure 8.13:** Components of a computer-controlled system. The controller consists of analog-to-digital (A/D) and digital-to-analog (D/A) converters, as well as a computer that implements the control algorithm. A system clock controls the operation of the controller, synchronizing the A/D, D/A and computing processes. The operator input is also fed to the computer as an external input.

neering applications most controllers are implemented using computers, we will briefly discuss how this can be done.

A computer-controlled system typically operates periodically: every cycle, signals from the sensors are sampled and converted to digital form by the A/D converter, the control signal is computed and the resulting output is converted to analog form for the actuators, as shown in Figure 8.13. To illustrate the main principles of how to implement feedback in this environment, we consider the controller described by equations (8.14) and (8.15), i.e.,

$$\frac{d\hat{x}}{dt} = A\hat{x} + Bu + L(y - C\hat{x}), \quad u = -K\hat{x} + k_r r.$$

The second equation consists only of additions and multiplications and can thus be implemented directly on a computer. The first equation can be implemented by approximating the derivative by a difference

$$\frac{d\hat{x}}{dt} \approx \frac{\hat{x}(t_{k+1}) - \hat{x}(t_k)}{h} = A\hat{x}(t_k) + Bu(t_k) + L(y(t_k) - C\hat{x}(t_k)),$$

where  $t_k$  are the sampling instants and  $h = t_{k+1} - t_k$  is the sampling period. Rewriting the equation to isolate  $\hat{x}(t_{k+1})$ , we get the difference equation

$$\hat{x}(t_{k+1}) = \hat{x}(t_k) + h(A\hat{x}(t_k) + Bu(t_k) + L(y(t_k) - C\hat{x}(t_k))). \quad (8.29)$$

The calculation of the estimated state at time  $t_{k+1}$  requires only addition and multiplication and can easily be done by a computer. A section of pseudocode for the program that performs this calculation is

```
% Control algorithm - main loop
```

```

r = adin(ch1)           % read reference
y = adin(ch2)           % get process output
u = K*(xd - xhat) + uff % compute control variable
daout(ch1, u)           % set analog output
xhat = xhat + h*(A*x+B*u+L*(y-C*x)) % update state estimate

```

The program runs periodically at a fixed rate  $h$ . Notice that the number of computations between reading the analog input and setting the analog output has been minimized by updating the state after the analog output has been set. The program has an array of states `xhat` that represents the state estimate. The choice of sampling period requires some care.

There are more sophisticated ways of approximating a differential equation by a difference equation. If the control signal is constant between the sampling instants, it is possible to obtain exact equations; see [ÅW97].

There are several practical issues that also must be dealt with. For example, it is necessary to filter measured signals before they are sampled so that the filtered signal has little frequency content above  $f_s/2$ , where  $f_s$  is the sampling frequency. This avoids a phenomena known as *aliasing*. If controllers with integral action are used, it is also necessary to provide protection so that the integral does not become too large when the actuator saturates. This issue, called *integrator windup*, is studied in more detail in Chapter 11. Care must also be taken so that parameter changes do not cause disturbances.

## 8.6 Further Reading

The notion of observability is due to Kalman [Kal61b] and, combined with the dual notion of reachability, it was a major stepping stone toward establishing state space control theory beginning in the 1960s. The observer first appeared as the Kalman filter, in the paper by Kalman [Kal61a] on the discrete-time case and Kalman and Bucy [KB61] on the continuous-time case. Kalman also conjectured that the controller for output feedback could be obtained by combining a state feedback with an observer; see the quote in the beginning of this chapter. This result was formally proved by Josep and Tou [JT61] and Gunckel and Franklin [GF71]. The combined result is known as the linear quadratic Gaussian control theory; a compact treatment is given in the books by Anderson and Moore [AM90] and Åström [Åst06]. Much later it was shown that solutions to robust control problems also had a similar structure but with different ways of computing observer and state feedback gains [DGKF89]. The general controller structure discussed in Section 8.5, which combines feedback and feedforward, was described by Horowitz in 1963 [Hor63]. The particular form in Figure 8.10 appeared in [ÅW97], which also treats digital implementation of the controller. The hypothesis that motion control in humans is based on a combination of feedback and feedforward was proposed by Ito in 1970 [Ito70].

## Exercises

**8.1** (Coordinate transformations) Consider a system under a coordinate transformation  $z = Tx$ , where  $T \in \mathbb{R}^{n \times n}$  is an invertible matrix. Show that the observability matrix for the transformed system is given by  $\tilde{W}_o = W_o T^{-1}$  and hence observability is independent of the choice of coordinates.

**8.2** Show that the system depicted in Figure 8.2 is not observable.

**8.3** (Observable canonical form) Show that if a system is observable, then there exists a change of coordinates  $z = Tx$  that puts the transformed system into observable canonical form.

**8.4** (Bicycle dynamics) The linearized model for a bicycle is given in equation (4.5), which has the form

$$J \frac{d^2 \varphi}{dt^2} - \frac{Dv_0}{b} \frac{d\delta}{dt} = mgh\varphi + \frac{mv_0^2 h}{b} \delta,$$

where  $\varphi$  is the tilt of the bicycle and  $\delta$  is the steering angle. Give conditions under which the system is observable and explain any special situations where it loses observability.

**8.5** (Integral action) The model (8.1) assumes that the input  $u = 0$  corresponds to  $x = 0$ . In practice, it is very difficult to know the value of the control signal that gives a precise value of the state or the output because this would require a perfectly calibrated system. One way to avoid this assumption is to assume that the model is given by

$$\frac{dx}{dt} = Ax + B(u + u_0), \quad y = Cx + Du,$$

where  $u_0$  is an unknown constant that can be modeled as  $du_0/dt = 0$ . Consider  $u_0$  as an additional state variable and derive a controller based on feedback from the observed state. Show that the controller has integral action and that it does not require a perfectly calibrated system.

**8.6** (Vectored thrust aircraft) The lateral dynamics of the vectored thrust aircraft example described in Example 7.8 can be obtained by considering the motion described by the states  $z = (x, \theta, \dot{x}, \dot{\theta})$ . Construct an estimator for these dynamics by setting the eigenvalues of the observer into a *Butterworth pattern* with  $\lambda_{bw} = -3.83 \pm 9.24i, -9.24 \pm 3.83i$ . Using this estimator combined with the state space controller computed in Example 7.8, plot the step response of the closed loop system. 

**8.7** (Uniqueness of observers) Show that the design of an observer by eigenvalue assignment is unique for single-output systems. Construct examples that show that the problem is not necessarily unique for systems with many outputs.

**8.8** (Observers using differentiation) Consider the linear system (8.2), and assume that the observability matrix  $W_o$  is invertible. Show that

$$\hat{x} = W_o^{-1} \begin{pmatrix} y & \dot{y} & \ddot{y} & \cdots & y^{(n-1)} \end{pmatrix}^T$$

is an observer. Show that it has the advantage of giving the state instantaneously but that it also has some severe practical drawbacks.



**8.9** (Observer for Teorell's compartment model) Teorell's compartment model, shown in Figure 4.17, has the following state space representation:

$$\frac{dx}{dt} = \begin{pmatrix} -k_1 & 0 & 0 & 0 & 0 \\ k_1 & -k_2 - k_4 & 0 & k_3 & 0 \\ 0 & k_4 & 0 & 0 & 0 \\ 0 & k_2 & 0 & -k_3 - k_5 & 0 \\ 0 & 0 & 0 & k_5 & 0 \end{pmatrix} x + \begin{pmatrix} 1 \\ 0 \\ 0 \\ 0 \\ 0 \end{pmatrix} u,$$

where representative parameters are  $k_1 = 0.02$ ,  $k_2 = 0.1$ ,  $k_3 = 0.05$ ,  $k_4 = k_5 = 0.005$ . The concentration of a drug that is active in compartment 5 is measured in the bloodstream (compartment 2). Determine the compartments that are observable from measurement of concentration in the bloodstream and design an estimator for these concentrations base on eigenvalue assignment. Choose the closed loop eigenvalues  $-0.03$ ,  $-0.05$  and  $-0.1$ . Simulate the system when the input is a pulse injection.

**8.10** (Observer design for motor drive) Consider the normalized model of the motor drive in Exercise 3.10 where the open loop system has the eigenvalues  $0, 0, -0.05 \pm i$ . A state feedback that gave a closed loop system with eigenvalues in  $-2, -1$  and  $-1 \pm i$  was designed in Exercise 7.12. Design an observer for the system that has eigenvalues  $-4, -2$  and  $-2 \pm 2i$ . Combine the observer with the state feedback from Exercise 7.12 to obtain an output feedback and simulate the complete system.

**8.11** (Feedforward design for motor drive) Consider the normalized model of the motor drive in Exercise 3.10. Design the dynamics of the block labeled "trajectory generation" in Figure 8.10 so that the dynamics relating the output  $\eta$  to the reference signal  $r$  has the dynamics

$$\frac{d^3 y_m}{dt^3} + a_{m1} \frac{d^2 y_m}{dt^2} + a_{m2} \frac{d y_m}{dt} + a_{m3} y_m = a_{m3} r, \quad (8.30)$$

with parameters  $a_{m1} = 2.5\omega_m$ ,  $a_{m2} = 2.5\omega_m^2$  and  $a_{m3} = \omega_m^3$ . Discuss how the largest value of the feedforward signal for a unit step in the command signal depends on  $\omega_m$ .

**8.12** (Whipple bicycle model) Consider the Whipple bicycle model given by equation (4.7) in Section 4.2. A state feedback for the system was designed in Exercise 7.13. Design an observer and an output feedback for the system.



**8.13** (Discrete-time random walk) Suppose that we wish to estimate the position of a particle that is undergoing a random walk in one dimension (i.e., along a line). We model the position of the particle as

$$x[k+1] = x[k] + u[k],$$

where  $x$  is the position of the particle and  $u$  is a white noise processes with  $E\{u[i]\} = 0$  and  $E\{u[i]u[j]\} = R_u\delta(i-j)$ . We assume that we can measure  $x$  subject to additive, zero-mean, Gaussian white noise with covariance 1.

- Compute the expected value and covariance of the particle as a function of  $k$ .
- Construct a Kalman filter to estimate the position of the particle given the noisy measurements of its position. Compute the steady-state expected value and covariance of the error of your estimate.
- Suppose that  $E\{u[0]\} = \mu \neq 0$  but is otherwise unchanged. How would your answers to parts (a) and (b) change?

**8.14** (Kalman decomposition) Consider a linear system characterized by the matrices

$$A = \begin{pmatrix} -2 & 1 & -1 & 2 \\ 1 & -3 & 0 & 2 \\ 1 & 1 & -4 & 2 \\ 0 & 1 & -1 & -1 \end{pmatrix}, \quad B = \begin{pmatrix} 2 \\ 2 \\ 2 \\ 1 \end{pmatrix}, \quad C = \begin{pmatrix} 0 & 1 & -1 & 0 \end{pmatrix}, \quad D = 0.$$

Construct a Kalman decomposition for the system. (Hint: Try to diagonalize.)





---

# Chapter Nine

## Transfer Functions

*The typical regulator system can frequently be described, in essentials, by differential equations of no more than perhaps the second, third or fourth order. . . In contrast, the order of the set of differential equations describing the typical negative feedback amplifier used in telephony is likely to be very much greater. As a matter of idle curiosity, I once counted to find out what the order of the set of equations in an amplifier I had just designed would have been, if I had worked with the differential equations directly. It turned out to be 55.*

Hendrik Bode, 1960 [Bod60].

This chapter introduces the concept of the *transfer function*, which is a compact description of the input/output relation for a linear time invariant system. To simplify the writing we will often drop time invariant in the text. Combining transfer functions with block diagrams gives a powerful method for dealing with complex linear systems. The relationship between transfer functions and other descriptions of system dynamics is also discussed.

### 9.1 Frequency Domain Modeling

Figure 9.1 is a block diagram for a typical control system, consisting of a process to be controlled and a controller that combines feedback and feedforward. We saw in the previous two chapters how to analyze and design such systems using state space descriptions of the blocks. As mentioned in Chapter 3, an alternative approach is to focus on the input/output characteristics of the system. Since it is the inputs and outputs that are used to connect the systems, one could expect that this

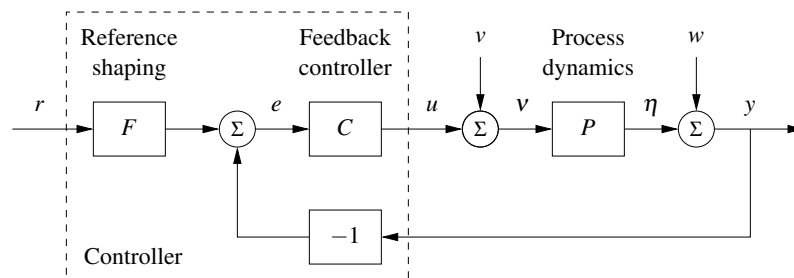

**Figure 9.1:** A block diagram for a feedback control system. The reference signal  $r$  is fed through a reference shaping block, which generates a signal which is compared with the output  $y$  to form the error  $e$ . The control signal  $u$  is generated by the controller which has the error as the input. The load disturbance  $v$  and the measurement noise  $w$  are external signals.

point of view would allow an understanding of the overall behavior of the system. Transfer functions are the main tool in implementing this point of view for linear systems.

The basic idea of the transfer function comes from looking at the frequency response of a system. Suppose that we have an input signal that is periodic. Then we can decompose this signal into the sum of a set of sines and cosines,

$$u(t) = \sum_{k=0}^{\infty} a_k \sin(k\omega t) + b_k \cos(k\omega t),$$

where  $\omega$  is the fundamental frequency of the periodic input. The input  $u(t)$  generates corresponding sine and cosine outputs (in steady state), with possibly shifted magnitude and phase. The gain and phase at each frequency are determined by the frequency response given in equation (6.24):

$$G(s) = C(sI - A)^{-1}B + D, \quad (9.1)$$

where we set  $s = i(k\omega)$  for each  $k = 1, \dots, \infty$  and  $i = \sqrt{-1}$ . If we know the steady-state frequency response  $G(s)$ , we can thus compute the response to any (periodic) signal using superposition. The transfer function generalizes this notion to allow a broader class of input signals besides periodic ones. As we shall see in the next section, the transfer function represents the response of the system to an *exponential input*,  $u = e^{st}$ . It turns out that the form of the transfer function is precisely the same as that of equation (9.1). This should not be surprising since we derived equation (9.1) by writing sinusoids as sums of complex exponentials. The transfer function can also be introduced as is the ratio of the Laplace transforms of output and input when the state is zero, although one does not have to understand the details of Laplace transforms in order to make use of transfer functions.

Modeling a system through its response to sinusoidal and exponential signals is known as *frequency domain modeling*. This terminology stems from the fact that we represent the dynamics of the system in terms of the generalized frequency  $s$  rather than the time domain variable  $t$ . The transfer function provides a complete representation of a linear system in the frequency domain.

The power of transfer functions is that they provide a particularly convenient representation in manipulating and analyzing complex linear feedback systems. As we shall see, there are graphical representations of transfer functions (Bode and Nyquist plots) that capture interesting properties of the underlying dynamics. Transfer functions also make it possible to express the changes in a system because of modeling error, which is essential when considering sensitivity to process variations of the sort discussed in Chapter 13. More specifically, using transfer functions, it is possible to analyze what happens when dynamic models are approximated by static models or when high-order models are approximated by low-order models. One consequence is that we can introduce concepts that express the degree of stability of a system.

While many of the concepts for state space modeling and analysis apply directly to nonlinear systems, frequency domain analysis applies primarily to linear

systems. The notions of gain and phase can, however, be generalized to nonlinear systems and, in particular, propagation of sinusoidal signals through a nonlinear system can approximately be captured by an analog of the frequency response called the describing function. These extensions of frequency response will be discussed in Section 10.5.

## 9.2 Determining the Transfer Function

As we have seen in previous chapters, the input/output dynamics of a linear system have two components: the initial condition response and the forced response, which depends on the system input. The forced response can be completely characterized by the transfer function. In Section 2.1 we briefly introduced the transfer function as the response to an exponential function  $e^{st}$ . In this section we will compute transfer functions for general linear systems and we will show that the transfer function is indeed a complete characterization of the input/output behavior of a linear system.

### Transmission of Exponential Signals

To formally compute the transfer function of a system, we will make use of a special type of signal, called an *exponential signal*, of the form  $e^{st}$ , where  $s = \sigma + i\omega$  is a complex number. Exponential signals play an important role in linear systems. They appear in the solution of differential equations and in the impulse response of linear systems, and many signals can be represented as exponentials or sums of exponentials. For example, a constant signal is simply  $e^{\alpha t}$  with  $\alpha = 0$ . Damped sine and cosine signals can be represented by

$$e^{(\sigma+i\omega)t} = e^{\sigma t} e^{i\omega t} = e^{\sigma t} (\cos \omega t + i \sin \omega t),$$

where  $\sigma < 0$  determines the decay rate. Figure 9.2 gives examples of signals that can be represented by complex exponentials; many other signals can be represented by linear combinations of these signals.

As in the case of the sinusoidal signals we considered in Section 6.3, we will allow complex-valued signals in the derivation that follows, although in practice we always add together combinations of signals that result in real-valued functions.

In Section 2.1 we showed that the transfer function  $G(s)$  of a linear time-invariant system can be obtained by computing a particular solution of the form  $y_p(t) = G(s)e^{st}$  when the input is  $u(t) = e^{st}$ , where  $s$  is a complex number. For example, the system

$$\frac{d^n y}{dt^n} + a_1 \frac{d^{n-1} y}{dt^{n-1}} + \cdots + a_n y = b_0 \frac{d^m u}{dt^m} + b_1 \frac{d^{m-1} u}{dt^{m-1}} + \cdots + b_m u,$$

has the transfer function

$$G(s) = \frac{b_0 s^m + b_1 s^{m-2} + \cdots + b_m}{s^n + a_1 s^{n-1} + \cdots + a_n};$$

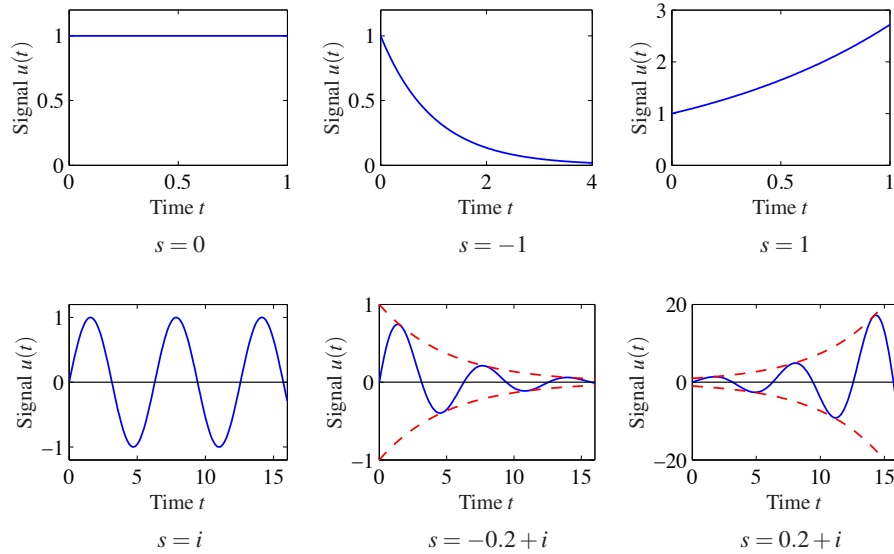

**Figure 9.2:** Examples of exponential signals. The top row corresponds to exponential signals with a real exponent, and the bottom row corresponds to those with complex exponents. The dashed line in the last two cases denotes the bounding envelope for the oscillatory signals. In each case, if the real part of the exponent is negative then the signal decays, while if the real part is positive then it grows.

see equations (2.2) and (2.7).

To find the transfer function for the state space system

$$\frac{dx}{dt} = Ax + Bu, \quad y = Cx + Du, \quad (9.2)$$

we let the input be the exponential signal  $u(t) = e^{st}$  and assume that  $s \notin \lambda(A)$ . The state is then given by

$$x(t) = e^{At}x(0) + \int_0^t e^{A(t-\tau)} B e^{s\tau} d\tau = e^{At}x(0) + e^{At}(sI - A)^{-1} \left( e^{(sI-A)t} - I \right) B.$$

The output  $y$  of equation (9.2) then becomes

$$\begin{aligned} y(t) &= Cx(t) + Du(t) \\ &= \underbrace{C e^{At} x(0)}_{\text{initial state response}} + \underbrace{\left( C(sI - A)^{-1} B + D \right) e^{st} - C e^{At} (sI - A)^{-1} B}_{\text{input response}} \\ &= \underbrace{C e^{At} \left( x(0) - (sI - A)^{-1} B \right)}_{\text{transient response}} + \underbrace{\left( C(sI - A)^{-1} B + D \right) e^{st}}_{\text{pure exponential response}}. \end{aligned} \quad (9.3)$$

and the *transfer function* from  $u$  to  $y$  of the system (9.2) is the coefficient of the

term  $e^{st}$ , hence

$$G(s) = C(sI - A)^{-1}B + D. \quad (9.4)$$

Compare this with the definition of frequency response given by equations (6.23) and (6.24).

An important point in the derivation of the transfer function is the fact that we have restricted  $s$  so that  $s \neq \lambda_j(A)$ , the eigenvalues of  $A$ . At those values of  $s$ , we see that the response (9.3) of the system is singular (since  $sI - A$  then is not invertible). The transfer function can, however, be extended to all values of  $s$  by analytic continuation.

To give some insight we will now discuss the equation (9.3). We first notice that the output  $y(t)$  can be separated in terms in two ways with different interpretations. The response of the system to initial conditions is  $Ce^{At}x(0)$ . Recall that  $e^{At}$  can be written in terms of the eigenvalues of  $A$  (using the Jordan form in the case of repeated eigenvalues), and hence the transient response is a linear combination of terms of the form  $p_j(t)e^{\lambda_j t}$ , where  $\lambda_j$  are eigenvalues of  $A$  and  $p_j(t)$  is a polynomial whose degree is less than the multiplicity of the eigenvalue, see Exercise 9.2.

The response to the input  $u(t) = e^{st}$  contains a mixture of terms  $p_j(t)e^{\lambda_j t}$  and the exponential function

$$y_p(t) = (C(sI - A)^{-1}B + D)e^{st}, \quad (9.5)$$

which is a *particular solution* to the differential equation (9.2). We call this solution the *pure exponential solution* because had only one exponential  $e^{st}$ . It follows from equation (9.3) that the output  $y(t)$  is equal to the pure exponential solution  $y_p(t)$  if the initial condition is chosen as

$$x(0) = (sI - A)^{-1}B. \quad (9.6)$$

If the system (9.2) is asymptotically stable, then  $e^{At} \rightarrow 0$  as  $t \rightarrow \infty$ . If in addition the input  $u(t)$  is a constant  $u(t) = e^{0 \cdot t}$  or a sinusoid  $u(t) = e^{i\omega t}$  the response then goes to a constant or sinusoidal *steady state solution*, see equation (6.23).

To simplify manipulation of the equations describing linear time invariant systems, we introduce  $\mathcal{E}$  as the class of time functions of the form  $X(s)e^{st}$ , where the parameters  $s$  is a complex variable and  $X(s)$  is a complex function (vector valued if  $f$  is a vector). It follows from equations (9.3, 9.4) that if a system with transfer function  $G(s)$  has the input  $u \in \mathcal{E}$  then there is a particular solution such that the output is  $y = Gu$ . This solution is the actual response of the system if the initial condition is chosen as equation (9.6). Since the transfer function of a system is given by the pure exponential response, we can derive transfer functions using exponential signals, and we will use the notation

$$y = Gu, \quad u, y \in \mathcal{E}, \quad (9.7)$$

but we must always be aware of the meaning of this notation.

### Example 9.1 Damped oscillator

Consider the response of a damped linear oscillator, whose state space dynamics

were studied in Section 7.3:

$$\frac{dx}{dt} = \begin{pmatrix} 0 & \omega_0 \\ -\omega_0 & -2\zeta\omega_0 \end{pmatrix} x + \begin{pmatrix} 0 \\ k\omega_0 \end{pmatrix} u, \quad y = \begin{pmatrix} 1 & 0 \end{pmatrix} x. \quad (9.8)$$

This system is asymptotically stable if  $\zeta > 0$ , and so we can look at the steady-state response to an input  $u = e^{st}$ ,

$$\begin{aligned} G_{yu}(s) &= C(sI - A)^{-1}B = \begin{pmatrix} 1 & 0 \end{pmatrix} \begin{pmatrix} s & -\omega_0 \\ \omega_0 & s + 2\zeta\omega_0 \end{pmatrix}^{-1} \begin{pmatrix} 0 \\ k\omega_0 \end{pmatrix} \\ &= \begin{pmatrix} 1 & 0 \end{pmatrix} \left( \frac{1}{s^2 + 2\zeta\omega_0s + \omega_0^2} \begin{pmatrix} s + 2\zeta\omega_0 & -\omega_0 \\ \omega_0 & s \end{pmatrix} \right) \begin{pmatrix} 0 \\ k\omega_0 \end{pmatrix} \\ &= \frac{k\omega_0^2}{s^2 + 2\zeta\omega_0s + \omega_0^2}. \end{aligned} \quad (9.9)$$

The steady-state response to a step input is obtained by setting  $s = 0$  which gives

$$u = 1 \quad \Longrightarrow \quad y = G_{yu}(0)u = k.$$

If we wish to compute the steady-state response to a sinusoid, we write

$$\begin{aligned} u &= \sin \omega t = \frac{1}{2} (ie^{-i\omega t} - ie^{i\omega t}), \\ y &= \frac{1}{2} (iG_{yu}(-i\omega)e^{-i\omega t} - iG_{yu}(i\omega)e^{i\omega t}). \end{aligned}$$

We can now write  $G(i\omega)$  in terms of its magnitude and phase,

$$G(i\omega) = \frac{k\omega_0^2}{-\omega^2 + (2\zeta\omega_0\omega)i + \omega_0^2} = Me^{i\theta},$$

where the magnitude (or gain)  $M$  and phase  $\theta$  are given by

$$M = \frac{k\omega_0^2}{\sqrt{(\omega_0^2 - \omega^2)^2 + (2\zeta\omega_0\omega)^2}}, \quad \frac{\sin \theta}{\cos \theta} = \frac{-2\zeta\omega_0\omega}{\omega_0^2 - \omega^2}.$$

We can also make use of the fact that  $G(-i\omega)$  is given by its complex conjugate  $G^*(i\omega)$ , and it follows that  $G(-i\omega) = Me^{-i\theta}$ . Substituting these expressions into our output equation, we obtain

$$\begin{aligned} y &= \frac{1}{2} \left( i(Me^{-i\theta})e^{-i\omega t} - i(Me^{i\theta})e^{i\omega t} \right) \\ &= M \cdot \frac{1}{2} \left( ie^{-i(\omega t + \theta)} - ie^{i(\omega t + \theta)} \right) = M \sin(\omega t + \theta). \end{aligned}$$

The responses to other signals can be computed by writing the input as an appropriate combination of exponential responses and using linearity.  $\nabla$

### Example 9.2 Electrical circuit elements

Modeling of electrical circuits is a common use of transfer functions. Consider, for example, a resistor modeled by Ohm's law  $V = IR$ , where  $V$  is the voltage across

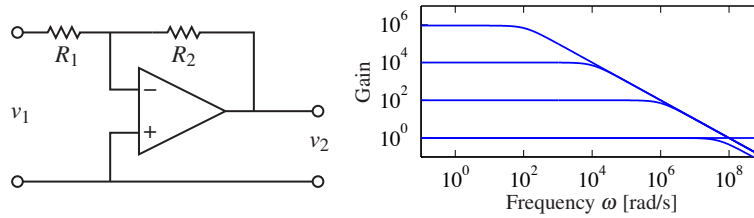

**Figure 9.3:** Stable amplifier based on negative feedback around an operational amplifier. The block diagram on the left shows a typical amplifier with low-frequency gain  $R_2/R_1$ . If we model the dynamic response of the op amp as  $G(s) = ak/(s+a)$ , then the gain falls off at frequency  $\omega = aR_1k/R_2$ , as shown in the gain curves on the right. The frequency response is computed for  $k = 10^7$ ,  $a = 10$  rad/s,  $R_2 = 10^6 \Omega$ , and  $R_1 = 1, 10^2, 10^4$  and  $10^6 \Omega$ .

the resistor,  $I$  is the current through the resistor and  $R$  is the resistance value. If we consider current to be the input and voltage to be the output, the resistor has the transfer function  $Z(s) = R$ .  $Z(s)$  is also called the *impedance* of the circuit element.

Next we consider an inductor whose input/output characteristic is given by

$$L \frac{dI}{dt} = V.$$

Letting the current be  $I(t) = e^{st}$ , we find that the voltage is  $V(t) = Lse^{st}$  and the transfer function of an inductor is thus  $Z(s) = Ls$ . A capacitor is characterized by

$$C \frac{dV}{dt} = I,$$

and a similar analysis gives a transfer function from current to voltage of  $Z(s) = 1/(Cs)$ . Using transfer functions, complex electrical circuits can be analyzed algebraically by using the complex impedance  $Z(s)$  just as one would use the resistance value in a resistor network.  $\nabla$

### Example 9.3 Operational amplifier circuit

To further illustrate the use of exponential signals, we consider the operational amplifier circuit described in Section 4.3 and reproduced in Figure 9.3 (left). The model in Section 4.3 is a simplification because the linear behavior of the amplifier is modeled as a constant gain. In reality there are significant dynamics in the amplifier, and the static model  $v_{\text{out}} = -kv$  (equation (4.10)) should therefore be replaced by a dynamic model  $v_{\text{out}} = -Gv$ . A simple transfer function is

$$G(s) = \frac{ak}{s+a}. \quad (9.10)$$

These dynamics correspond to a first-order system with time constant  $1/a$ . The parameter  $k$  is called the *open loop gain*, and the product  $ak$  is called the *gain-bandwidth product*; typical values for these parameters are  $k = 10^7$  and  $ak = 10^7$ – $10^9$  rad/s.

If the input  $v_1$  is an exponential signal  $e^{st}$ , then there are solutions where all signals in the circuit are exponentials,  $v, v_1, v_2 \in \mathcal{E}$ , since all of the elements of the

circuit are modeled as being linear. The equations describing the system can then be manipulated algebraically.

Assuming that the current into the amplifier is zero, as is done in Section 4.3, the current through the resistors  $R_1$  and  $R_2$  are the same, hence

$$\frac{v_1 - v}{R_1} = \frac{v - v_2}{R_2}, \quad \text{or} \quad (R_1 + R_2)v = R_2v_1 + R_1v_2$$

Combining the above equation with the open loop dynamics of the operational amplifier (9.10), which can be written as  $v_2 = -Gv$  in the simplified notation (9.7), then give the following model for the closed loop system:

$$(R_1 + R_2)v = R_2v_1 + R_1v_2, \quad v_2 = -Gv, \quad v, v_1, v_2 \in \mathcal{E}. \quad (9.11)$$

Eliminating  $v$  between these equations gives

$$v_2 = \frac{-R_2G(s)}{R_1 + R_2 + R_1G(s)}v_1 = \frac{-R_2ak}{R_1ak + (R_1 + R_2)(s + a)}v_1.$$

and the transfer function of the closed loop system is

$$G_{v_2v_1} = \frac{-R_2ak}{R_1ak + (R_1 + R_2)(s + a)}. \quad (9.12)$$

The low-frequency gain is obtained by setting  $s = 0$ , hence

$$G_{v_2v_1}(0) = \frac{-kR_2}{(k+1)R_1 + R_2} \approx -\frac{R_2}{R_1},$$

which is the result given by equation (4.11) in Section 4.3. The bandwidth of the amplifier circuit is

$$\omega_b = a \frac{R_1(k+1) + R_2}{R_1 + R_2} \approx a \frac{R_1k}{R_2} \quad \text{for} \quad k \gg 1,$$

where the approximation holds for  $R_2/R_1 \gg 1$ . The gain of the closed loop system drops off at high frequencies as  $R_2k/(\omega(R_1 + R_2))$ . The frequency response of the transfer function is shown in Figure 9.3 (right) for  $k = 10^7$ ,  $a = 10$  rad/s,  $R_2 = 10^6 \Omega$  and  $R_1 = 1, 10^2, 10^4$  and  $10^6 \Omega$ .

Note that in solving this example, we bypassed explicitly writing the signals as  $v = Ve^{st}$  and instead worked directly with  $V$ , assuming it was an exponential. This shortcut is handy in solving problems of this sort and when manipulating block diagrams. A comparison with Section 4.3, where we make the same calculation when  $G(s)$  is a constant, shows analysis of systems using transfer functions is as easy as using static systems. The calculations are the same if the resistances  $R_1$  and  $R_2$  are replaced by impedances, as discussed in Example 9.2.  $\nabla$



Although we have focused thus far on ordinary differential equations, transfer functions can also be used for other types of linear systems. We illustrate this by time delays and systems described by a partial differential equation.



**Example 9.4 Time Delay**

Time delays appear in many systems: typical examples are delays in nerve propagation, communication and mass transport. A system with a time delay has the input/output relation

$$y(t) = u(t - \tau). \quad (9.13)$$

To obtain the corresponding transfer function we let the input be  $u(t) = e^{st}$ , the output is then

$$y(t) = u(t - \tau) = e^{s(t-\tau)} = e^{-s\tau} e^{st} = e^{-s\tau} u(t).$$

and we find that the transfer function of a time delay is thus  $G(s) = e^{-s\tau}$ , which is not a rational function.  $\nabla$

**Example 9.5 Heat propagation**

Consider the problem of one-dimensional heat propagation in a semi-infinite metal rod. Assume that the input is the temperature at one end and that the output is the temperature at a point along the rod. Let  $\theta(x, t)$  be the temperature at position  $x$  and time  $t$ . With a proper choice of length scales and units, heat propagation is described by the partial differential equation

$$\frac{\partial \theta}{\partial t} = \frac{\partial^2 \theta}{\partial x^2}, \quad y(t) = \theta(1, t) \quad (9.14)$$

and the point of interest can be assumed to have  $x = 1$ . The boundary condition for the partial differential equation is

$$\theta(0, t) = u(t).$$

To determine the transfer function we choose the input as  $u(t) = e^{st}$ . Assume that there is a solution to the partial differential equation of the form  $\theta(x, t) = \psi(x)e^{st}$  and insert this into equation (9.14) to obtain

$$s\psi(x) = \frac{d^2 \psi}{dx^2},$$

with boundary condition  $\psi(0) = 1$ . This ordinary differential equation (with independent variable  $x$ ) has the solution

$$\psi(x) = Ae^{x\sqrt{s}} + Be^{-x\sqrt{s}}.$$

Since the temperature of the rod is bounded we have  $A = 0$ , the boundary condition gives  $B = 1$ , and the solution is then

$$y(t) = \theta(1, t) = \psi(1)e^{st} = e^{-\sqrt{s}} e^{st} = e^{-\sqrt{s}} u(t).$$

The system thus has the transfer function  $G(s) = e^{-\sqrt{s}}$ . As in the case of a time delay, the transfer function is not a rational function but is analytic except at  $s = 0$ .  $\nabla$

Transfer function for some common linear time-invariant systems are given in Table 9.1.

**Table 9.1:** Transfer functions for some common linear time-invariant systems.

Type	System	Transfer Function
Integrator	$\dot{y} = u$	$\frac{1}{s}$
Differentiator	$y = \dot{u}$	$s$
First-order system	$\dot{y} + ay = u$	$\frac{1}{s+a}$
Double integrator	$\ddot{y} = u$	$\frac{1}{s^2}$
Damped oscillator	$\ddot{y} + 2\zeta\omega_0\dot{y} + \omega_0^2y = u$	$\frac{1}{s^2 + 2\zeta\omega_0s + \omega_0^2}$
State space system	$\dot{x} = Ax + Bu, y = Cx + Du$	$C(sI - A)^{-1}B + D$
PID controller	$y = k_p u + k_d \dot{u} + k_i \int u$	$k_p + k_d s + \frac{k_i}{s}$
Time delay	$y(t) = u(t - \tau)$	$e^{-\tau s}$



## Laplace Transforms

Traditionally, Laplace transforms were used to compute responses of linear systems to different stimuli. Today we can easily generate the responses using computers. Laplace transforms were also used to derive transfer functions which we illustrate in this section. Only a few elementary properties are needed for basic control applications. Students who are not familiar with them can safely skip this section. A good reference for the mathematical material in this section is the classic book by Widder [Wid41].

Consider a function  $f(t)$ ,  $f: \mathbb{R}^+ \rightarrow \mathbb{R}$ , that is integrable and grows no faster than  $e^{s_0 t}$  for some finite  $s_0 \in \mathbb{R}$  and large  $t$ . The Laplace transform maps  $f$  to a function  $F = \mathcal{L}f: \mathbb{C} \rightarrow \mathbb{C}$  of a complex variable. It is defined by

$$F(s) = \int_0^{\infty} e^{-st} f(t) dt, \quad \operatorname{Re} s > s_0. \quad (9.15)$$

The transform has some properties that makes it well suited to deal with linear systems. First we observe that the transform is linear because

$$\begin{aligned} \mathcal{L}(af + bg) &= \int_0^{\infty} e^{-st} (af(t) + bg(t)) dt \\ &= a \int_0^{\infty} e^{-st} f(t) dt + b \int_0^{\infty} e^{-st} g(t) dt = a\mathcal{L}f + b\mathcal{L}g. \end{aligned} \quad (9.16)$$

Next we will calculate the Laplace transform of the integral of a function. Using

integration by parts, we get

$$\begin{aligned}\mathcal{L} \int_0^t f(\tau) d\tau &= \int_0^\infty \left( e^{-st} \int_0^t f(\tau) d\tau \right) dt \\ &= -\frac{e^{-st}}{s} \int_0^t f(\tau) d\tau \Big|_0^\infty + \int_0^\infty \frac{e^{-s\tau}}{s} f(\tau) d\tau = \frac{1}{s} \int_0^\infty e^{-s\tau} f(\tau) d\tau,\end{aligned}$$

hence

$$\mathcal{L} \int_0^t f(\tau) d\tau = \frac{1}{s} \mathcal{L} f = \frac{1}{s} F(s). \quad (9.17)$$

*Integration of a time function thus corresponds to division of the corresponding Laplace transform by  $s$ .*

Since integration corresponds to division by  $s$ , we can expect that differentiation corresponds to multiplication by  $s$ . This is not quite true as we will see by calculating the Laplace transform of the derivative of a function. We have

$$\mathcal{L} \frac{df}{dt} = \int_0^\infty e^{-st} f'(t) dt = e^{-st} f(t) \Big|_0^\infty + s \int_0^\infty e^{-st} f(t) dt = -f(0) + s \mathcal{L} f,$$

where the second equality is obtained using integration by parts. We thus obtain

$$\mathcal{L} \frac{df}{dt} = s \mathcal{L} f - f(0) = sF(s) - f(0). \quad (9.18)$$

Notice that the appearance of the initial value  $f(0)$  of the function. The formula (9.18) is particularly simple if the initial conditions are zero, because if  $f(0) = 0$  it follows that *differentiation of a function corresponds to multiplication of the transform by  $s$* , compare with the differentiation of exponential signals.

Using Laplace transforms the transfer function for a linear time invariant system can be defined as *the ratio of the transform of the input and the output, when the transforms are computed under the assumption that all initial conditions are zero*. We will now illustrate how Laplace transforms can be used to compute transfer functions.

### Example 9.6 Transfer function of state space model

Consider the state space system described by equation (9.2). Taking Laplace transforms give

$$sX(s) - x(0) = AX(s) + BU(s) \quad Y(s) = CX(s) + DU(s).$$

Elimination of  $X(s)$  gives

$$X(s) = (sI - A)^{-1}x(0) + (sI - A)^{-1}BU(s). \quad (9.19)$$

When the initial condition  $x(0)$  is zero we have

$$X(s) = (sI - A)^{-1}BU(s), \quad Y(s) = \left( C(sI - A)^{-1}B + D \right) U(s).$$

and the transfer function is  $G(s) = C(sI - A)^{-1}B + D$ , compare with equation (9.4).

▽

**Example 9.7 Transfer function and impulse response**

Consider a linear time-invariant system with zero initial state. We saw in Section 6.3 that the relation between the input  $u$  and the output  $y$  is given by the convolution integral

$$y(t) = \int_0^{\infty} h(t - \tau)u(\tau) d\tau,$$

where  $h(t)$  is the impulse response for the system. Taking the Laplace transform of this expression gives

$$\begin{aligned} Y(s) &= \int_0^{\infty} e^{-st}y(t) dt = \int_0^{\infty} e^{-st} \int_0^{\infty} h(t - \tau)u(\tau) d\tau dt \\ &= \int_0^{\infty} \int_0^t e^{-s(t-\tau)} e^{-s\tau} h(t - \tau)u(\tau) d\tau dt \\ &= \int_0^{\infty} e^{-s\tau} u(\tau) d\tau \int_0^{\infty} e^{-st} h(t) dt = H(s)U(s). \end{aligned}$$

Thus, the input/output response is given by  $Y(s) = H(s)U(s)$ , where  $H$ ,  $U$  and  $Y$  are the Laplace transforms of  $h$ ,  $u$  and  $y$ .

The system theoretic interpretation is that the Laplace transform of the output of a linear system is a product of two terms, the Laplace transform of the input  $U(s)$  and the Laplace transform of the impulse response of the system  $H(s)$ . A mathematical interpretation is that the Laplace transform of a convolution is the product of the transforms of the functions that are convolved. The fact that the formula  $Y(s) = H(s)U(s)$  is much simpler than a convolution is one reason why Laplace transforms have become popular in engineering.  $\nabla$

**Coordinate Changes**

The matrices  $A$ ,  $B$  and  $C$  in equation (9.2) depend on the choice of coordinate system for the states. Since the transfer function relates input to outputs, it should be invariant to coordinate changes in the state space. To show this, consider the model (9.2) and introduce new coordinates  $z$  by the transformation  $z = Tx$ , where  $T$  is a nonsingular matrix. The system is then described by

$$\begin{aligned} \frac{dz}{dt} &= T(Ax + Bu) = TAT^{-1}z + TBu =: \tilde{A}z + \tilde{B}u, \\ y &= Cx + Du = CT^{-1}z + Du =: \tilde{C}z + Du. \end{aligned}$$

This system has the same form as equation (9.2), but the matrices  $A$ ,  $B$  and  $C$  are different:

$$\tilde{A} = TAT^{-1}, \quad \tilde{B} = TB, \quad \tilde{C} = CT^{-1}. \quad (9.20)$$

Computing the transfer function of the transformed model, we get

$$\begin{aligned} \tilde{G}(s) &= \tilde{C}(sI - \tilde{A})^{-1}\tilde{B} + \tilde{D} = CT^{-1}(sI - TAT^{-1})^{-1}TB + D \\ &= C(T^{-1}(sI - TAT^{-1})T)^{-1}B + D = C(sI - A)^{-1}B + D = G(s), \end{aligned}$$

which is identical to the transfer function (9.4) computed from the system description (9.2). The transfer function is thus invariant to changes of the coordinates in the state space.

### 9.3 Gain Poles and Zeros

The transfer function has many useful interpretations and the features of a transfer function are often associated with important system properties. Three of the most important features are the gain and the locations of the poles and zeros.

#### Gain

The *zero frequency gain* of a system is given by the magnitude of the transfer function at  $s = 0$ . It represents the ratio of the steady-state value of the output with respect to a step input (which can be represented as  $u = e^{st}$  with  $s = 0$ ). For a state space system, we computed the zero frequency gain in equation (6.22):

$$G(0) = D - CA^{-1}B.$$

Consider a stable system modeled by the linear differential equation

$$\frac{d^n y}{dt^n} + a_1 \frac{d^{n-1} y}{dt^{n-1}} + \cdots + a_n y = b_0 \frac{d^m u}{dt^m} + b_1 \frac{d^{m-1} u}{dt^{m-1}} + \cdots + b_m u.$$

If we assume that the input and output of the system are constants  $y_0$  and  $u_0$ , then we find that  $a_n y_0 = b_m u_0$ , and the zero frequency gain is

$$G(0) = \frac{y_0}{u_0} = \frac{b_m}{a_n}. \quad (9.21)$$

Recall that in Section 6.3 equation (6.24) we introduced the notion of gain and phase for the steady-state response  $G(i\omega)$  to sinusoidal signals.

#### Poles and Zeros

Next consider a linear system with the rational transfer function

$$G(s) = \frac{b(s)}{a(s)}.$$

The roots of the polynomial  $a(s)$  are called the *poles* of the system, and the roots of  $b(s)$  are called the *zeros* of the system. A pole  $p$  corresponds to a *mode* of the system with corresponding modal solution  $e^{pt}$ . The unforced motion of the system after an arbitrary excitation is a weighted sum of modes.

Zeros have a different interpretation. Since the pure exponential output corresponding to the input  $u(t) = e^{st}$  with  $a(s) \neq 0$  is  $G(s)e^{st}$ , it follows that the pure exponential output is zero if  $b(s) = 0$ . Zeros of the transfer function thus block transmission of the corresponding exponential signals.

For a state space system with transfer function  $G(s) = C(sI - A)^{-1}B + D$ , the poles of the transfer function are the eigenvalues of the matrix  $A$  in the state space model. One easy way to see this is to notice that the value of  $G(s)$  is unbounded when  $s$  is an eigenvalue of a system since this is precisely the set of points where the characteristic polynomial  $\lambda(s) = \det(sI - A) = 0$  (and hence  $sI - A$  is non-invertible). It follows that the poles of a state space system depend only on the matrix  $A$ , which represents the intrinsic dynamics of the system. We say that a transfer function is stable if all of its poles have negative real part.

To find the zeros of a state space system, we observe that the zeros are complex numbers  $s$  such that the input  $u(t) = U_0 e^{st}$  gives zero output. Inserting the pure exponential response  $x(t) = X_0 e^{st}$  and setting  $y(t) = 0$  in equation (9.2) gives

$$s e^{st} x_0 = A X_0 e^{st} + B U_0 e^{st} \quad 0 = C e^{st} X_0 + D e^{st} U_0,$$

which can be written as

$$\begin{pmatrix} A - sI & B \\ C & D \end{pmatrix} \begin{pmatrix} X_0 \\ U_0 \end{pmatrix} e^{st} = 0.$$

This equation has a solution with nonzero  $X_0, U_0$  only if the matrix on the left does not have full column rank. The zeros are thus the values  $s$  such that the matrix

$$\begin{pmatrix} A - sI & B \\ C & D \end{pmatrix} \quad (9.22)$$

loses rank.

Since the zeros depend on  $A, B, C$  and  $D$ , they therefore depend on how the inputs and outputs are coupled to the states. Notice in particular that if the matrix  $B$  has full row rank, then the matrix in equation (9.22) has  $n$  linearly independent rows for all values of  $s$ . Similarly there are  $n$  linearly independent columns if the matrix  $C$  has full column rank. This implies that systems where the matrix  $B$  or  $C$  is square and full rank do not have zeros. In particular it means that a system has no zeros if it is fully actuated (each state can be controlled independently) or if the full state is measured.

A convenient way to view the poles and zeros of a transfer function is through a *pole zero diagram*, as shown in Figure 9.4. In this diagram, each pole is marked with a cross, and each zero with a circle. If there are multiple poles or zeros at a fixed location, these are often indicated with overlapping crosses or circles (or other annotations). Poles in the left half-plane correspond to stable modes of the system, and poles in the right half-plane correspond to unstable modes. We thus call a pole in the left-half plane a *stable pole* and a pole in the right-half plane an *unstable pole*. A similar terminology is used for zeros, even though the zeros do not directly relate to stability or instability of the system. Notice that the gain must also be given to have a complete description of the transfer function.

### Example 9.8 Balance system

Consider the dynamics for a balance system, shown in Figure 9.5. The transfer function for a balance system can be derived directly from the second-order equa-

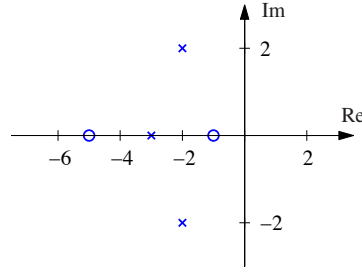

**Figure 9.4:** A pole zero diagram for a transfer function with zeros at  $-5$  and  $-1$  and poles at  $-3$  and  $-2 \pm 2j$ . The circles represent the locations of the zeros, and the crosses the locations of the poles. A complete characterization requires we also specify the gain of the system.

tions, given in Example 3.1:

$$\begin{aligned} M_t \frac{d^2 p}{dt^2} - ml \frac{d^2 \theta}{dt^2} \cos \theta + c \frac{dp}{dt} + ml \sin \theta \left( \frac{d\theta}{dt} \right)^2 &= F, \\ -ml \cos \theta \frac{d^2 p}{dt^2} + J_t \frac{d^2 \theta}{dt^2} + \gamma \frac{d\theta}{dt} - mgl \sin \theta &= 0. \end{aligned}$$

If we assume that  $\theta$  and  $\dot{\theta}$  are small, we can approximate this nonlinear system by a set of linear second-order differential equations,

$$\begin{aligned} M_t \frac{d^2 p}{dt^2} - ml \frac{d^2 \theta}{dt^2} + c \frac{dp}{dt} &= F, \\ -ml \frac{d^2 p}{dt^2} + J_t \frac{d^2 \theta}{dt^2} + \gamma \frac{d\theta}{dt} - mgl \theta &= 0. \end{aligned}$$

If we let  $F$  be an exponential signal, the resulting response satisfies

$$\begin{aligned} M_t s^2 p - ml s^2 \theta + cs p &= F, \\ J_t s^2 \theta - ml s^2 p + \gamma s \theta - mgl \theta &= 0, \end{aligned}$$

where all signals are exponential signals. The resulting transfer functions for the position of the cart and the orientation of the pendulum are given by solving for  $p$  and  $\theta$  in terms of  $F$  to obtain

$$\begin{aligned} H_{\theta F} &= \frac{mls}{(M_t J_t - m^2 l^2) s^3 + (\gamma M_t + c J_t) s^2 + (c \gamma - M_t mgl) s - mgl c}, \\ H_{pF} &= \frac{J_t s^2 + \gamma s - mgl}{(M_t J_t - m^2 l^2) s^4 + (\gamma M_t + c J_t) s^3 + (c \gamma - M_t mgl) s^2 - mgl c s}, \end{aligned}$$

where each of the coefficients is positive. The pole zero diagrams for these two transfer functions are shown in Figure 9.5 using the parameters from Example 7.7.

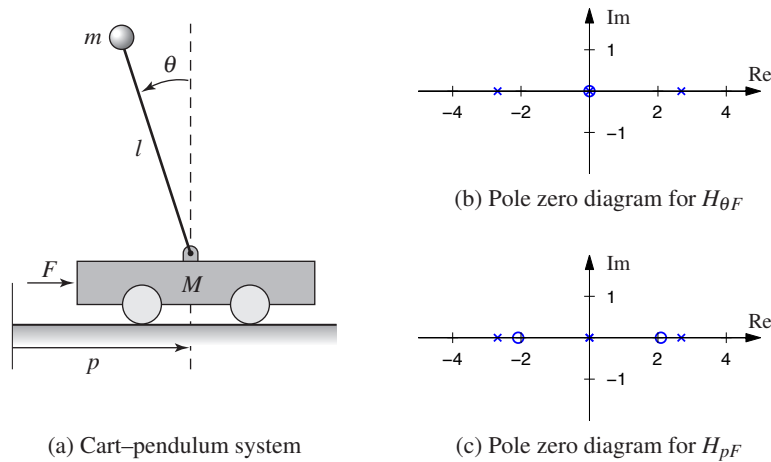

**Figure 9.5:** Poles and zeros for a balance system. The balance system (a) can be modeled around its vertical equilibrium point by a fourth order linear system. The poles and zeros for the transfer functions  $H_{\theta F}$  and  $H_{pF}$  are shown in (b) and (c), respectively.

If we assume the damping is small and set  $c = 0$  and  $\gamma = 0$ , we obtain

$$H_{\theta F} = \frac{ml}{(M_t J_t - m^2 l^2) s^2 - M_t mgl},$$

$$H_{pF} = \frac{J_t s^2 - mgl}{s^2 ((M_t J_t - m^2 l^2) s^2 - M_t mgl)}.$$

This gives nonzero poles and zeros at

$$p = \pm \sqrt{\frac{mgl M_t}{M_t J_t - m^2 l^2}} \approx \pm 2.68, \quad z = \pm \sqrt{\frac{mgl}{J_t}} \approx \pm 2.09.$$

We see that these are quite close to the pole and zero locations in Figure 9.5.  $\nabla$

### Pole/Zero Cancellations

Because transfer functions are often polynomials in  $s$ , it can sometimes happen that the numerator and denominator have a common factor, which can be canceled. Sometimes these cancellations are simply algebraic simplifications, but in other situations they can mask potential fragilities in the model. In particular, if a pole/zero cancellation occurs because terms in separate blocks that just happen to coincide, the cancellation may not occur if one of the systems is slightly perturbed. In some situations this can result in severe differences between the expected behavior and the actual behavior.

Consider the block diagram in Figure 9.8 with  $F = 1$  (no feedforward compen-



sation) and let  $C$  and  $P$  be given by

$$C(s) = \frac{n_c(s)}{d_c(s)}, \quad P(s) = \frac{n_p(s)}{d_p(s)}.$$

The transfer function from  $r$  to  $e$  is then given by

$$G_{er}(s) = \frac{1}{1 + PC} = \frac{d_c(s)d_p(s)}{d_c(s)d_p(s) + n_c(s)n_p(s)}.$$

If there are common factors in the numerator and denominator polynomials, then these terms can be factored out and eliminated from both the numerator and denominator. For example, if the controller has a zero at  $s = -a$  and the process has a pole at  $s = -a$ , then we will have

$$G_{er}(s) = \frac{(s+a)d_c(s)d'_p(s)}{(s+a)d_c(s)d'_p(s) + (s+a)n'_c(s)n_p(s)} = \frac{d_c(s)d'_p(s)}{d_c(s)d'_p(s) + n'_c(s)n_p(s)},$$

where  $n'_c(s)$  and  $d'_p(s)$  represent the relevant polynomials with the term  $s+a$  factored out and it does not appear in the transfer function  $G_{er}$ .

Suppose instead that we compute the transfer function from  $v$  to  $e$ , which represents the effect of a disturbance on the error between the reference and the output. This transfer function is given by

$$G_{ev}(s) = -\frac{d_c(s)n_p(s)}{(s+a)d_c(s)d'_p(s) + (s+a)n'_c(s)n_p(s)}.$$

Notice that if  $a < 0$ , then the pole is in the right half-plane and the transfer function  $G_{ev}$  is *unstable*. Hence, even though the transfer function from  $r$  to  $e$  appears to be okay (assuming a perfect pole/zero cancellation), the transfer function from  $v$  to  $e$  can exhibit unbounded behavior. This unwanted behavior is typical of an *unstable pole/zero cancellation*.

It turns out that the cancellation of a pole with a zero can also be understood in terms of the state space representation of the systems. Reachability or observability is lost when there are cancellations of poles and zeros (Exercise 9.11). A consequence is that the transfer function represents the dynamics only in the reachable and observable subsystem (see Section 8.5).

Another property of the transfer function is that it corresponds to the portion of the state space dynamics that is both reachable and observable. In particular, if we make use of the Kalman decomposition (Section 8.5), then the transfer function depends only on the dynamics in the reachable and observable subspace  $\Sigma_{ro}$  (Exercise 9.7). 

### Example 9.9 Cruise control

The input/output response from throttle to velocity for the linearized model for a car has the transfer function  $G(s) = b/(s+a)$ . A simple (but not necessarily good) way to design a PI controller is to choose the parameters of the PI controller as  $k_i = ak_p$ . The controller zero at  $s = -k_i/k_p = -a$  then cancels the process pole at

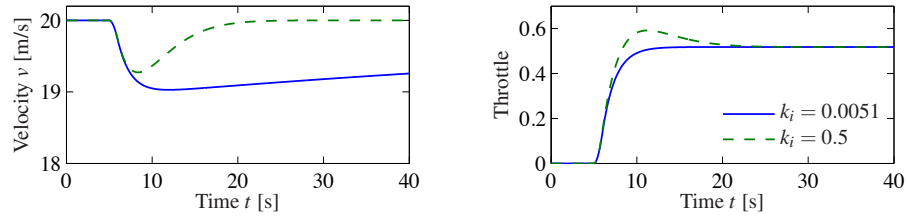

**Figure 9.6:** Car with PI cruise control encountering a sloping road. The velocity error is shown on the left and the throttle is shown on the right. Results with a PI controller with  $k_p = 0.5$  and  $k_i = 0.0051$ , where the process pole  $s = -0.0101$ , is shown by solid lines, and a controller with  $k_p = 0.5$  and  $k_i = 0.5$  is shown by dashed lines. Compare with Figure 4.3b.

$s = -a$ . The transfer function from reference to velocity is  $G_{vr}(s) = bk_p/(s + bk_p)$ , and control design is then simply a matter of choosing the gain  $k_p$ . The closed loop system dynamics are of first order with the time constant  $1/bk_p$ .

Figure 9.6 shows the velocity error when the car encounters an increase in the road slope. A comparison with the controller used in Figure 4.3b (reproduced in dashed curves) shows that the controller based on pole/zero cancellation has very poor performance. The velocity error is larger, and it takes a long time to settle.

Notice that the control signal remains practically constant after  $t = 15$  even if the error is large after that time. To understand what happens we will analyze the system. The parameters of the system are  $a = 0.0101$  and  $b = 1.32$ , and the controller parameters are  $k_p = 0.5$  and  $k_i = 0.0051$ . The closed loop time constant is  $1/(bk_p) = 2.5$  s, and we would expect that the error would settle in about 10 s (4 time constants). The transfer functions from road slope to velocity and control signals are

$$G_{v\theta}(s) = \frac{b_g s}{(s + a)(s + bk_p)}, \quad G_{u\theta}(s) = \frac{bk_p}{s + bk_p}.$$

Notice that the canceled mode  $s = a = -0.0101$  appears in  $G_{v\theta}$  but not in  $G_{u\theta}$ . The reason why the control signal remains constant is that the controller has a zero at  $s = -0.0101$ , which cancels the slowly decaying process mode. Notice that the error would diverge if the canceled pole was unstable.  $\nabla$

The lesson we can learn from this example is that it is a bad idea to try to cancel unstable or slow process poles. A more detailed discussion of pole/zero cancellations is given in Section 13.4.

## 9.4 Block Diagrams and Transfer Functions

The combination of block diagrams and transfer functions is a powerful way to represent control systems. Transfer functions relating different signals in the system can be derived by purely algebraic manipulations of the transfer functions of the blocks using *block diagram algebra*. To show how this can be done, we will

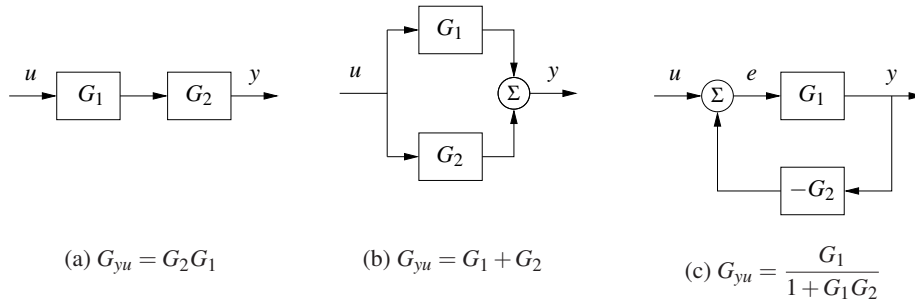

**Figure 9.7:** Interconnections of linear systems. Series (a), parallel (b) and feedback (c) connections are shown. The transfer functions for the composite systems can be derived by algebraic manipulations assuming exponential functions for all signals.

begin with simple combinations of systems. We will assume that all signals are exponential signals  $\mathcal{E}$  and we will use the compact notation  $y = Gu$  for the output  $y \in \mathcal{E}$  of a linear time-invariant system with the input  $u \in \mathcal{E}$  and the transfer function  $G$ , see equation (9.7) and recall its interpretation.

Consider a system that is a cascade combination of systems with the transfer functions  $G_1(s)$  and  $G_2(s)$ , as shown in Figure 9.7a. Let the input of the system be  $u \in \mathcal{E}$ . The output of the first block is then  $G_1u \in \mathcal{E}$ , which is also the input to the second system. The output of the second system is then

$$y = G_2(G_1u) = (G_2G_1)u, \quad u, y \in \mathcal{E}. \quad (9.23)$$

Let  $u = e^{st}$  be the input to the system,  $y$  be the pure exponential output, and  $e$  be the pure exponential part of the intermediate signal given by the sum of  $u$  and the output of the second block. The transfer function of the series connection is thus  $G = G_2G_1$ , i.e., the product of the transfer functions. The order of the individual transfer functions is due to the fact that we place the input signal on the right-hand side of this expression, hence we first multiply by  $G_1$  and then by  $G_2$ . Unfortunately, this has the opposite ordering from the diagrams that we use, where we typically have the signal flow from left to right, so one needs to be careful. The ordering is important if either  $G_1$  or  $G_2$  is a vector-valued transfer function, as we shall see in some examples.

Consider next a parallel connection of systems with the transfer functions  $G_1$  and  $G_2$ , as shown in Figure 9.7b and assume that all signals are exponential signals. The outputs of the first and second systems are simply  $G_1u$  and  $G_2u$  and the output of the parallel connection is

$$y = G_1u + G_2u = (G_1 + G_2)u, \quad u, y \in \mathcal{E}.$$

The transfer function for a parallel connection is thus  $G = G_1 + G_2$ .

Finally, consider a feedback connection of systems with the transfer functions  $G_1$  and  $G_2$ , as shown in Figure 9.7c. Writing the relations between the signals for the different blocks and the summation unit, we find

$$y = G_1e, \quad e = u - G_2y, \quad y, e, u \in \mathcal{E}. \quad (9.24)$$

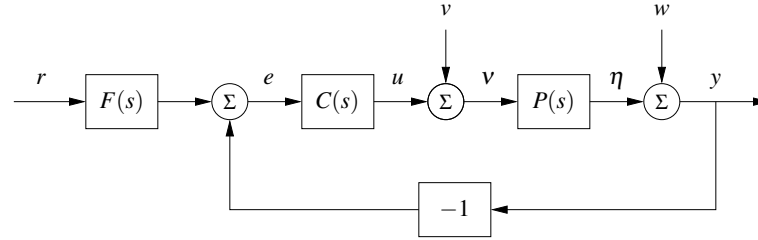

**Figure 9.8:** Block diagram of a feedback system. The inputs to the system are the reference signal  $r$ , the process disturbance  $v$  and the measurement noise  $w$ . The remaining signals in the system can all be chosen as possible outputs, and transfer functions can be used to relate the system inputs to the other labeled signals.

Elimination of  $e$  gives

$$y = G_1(u - G_2y) \implies (1 + G_1G_2)y = G_1u \implies y = \frac{G_1}{1 + G_1G_2}u.$$

The transfer function of the feedback connection is thus

$$G = \frac{G_1}{1 + G_1G_2}. \quad (9.25)$$

These three basic interconnections can be used as the basis for computing transfer functions for more complicated systems.

### Control System Transfer Functions

Consider the system in Figure 9.8, which was given at the beginning of the chapter. The system has three blocks representing a process  $P$ , a feedback controller  $C$  and a feedforward controller  $F$ . Together,  $C$  and  $F$  define the *control law* for the system. There are three external signals: the reference (or command signal)  $r$ , the load disturbance  $v$  and the measurement noise  $w$ . A typical problem is to find out how the error  $e$  is related to the signals  $r$ ,  $v$  and  $w$ .

To derive the transfer functions we are interested in we assume that all signals are exponential signals  $\mathcal{E}$  and we write the relations between the signals for each block in the block transfer function. Assume for example that we are interested in the control error  $e$ . The summation point and the block  $F(s)$  gives

$$e = Fr - y, \quad e, r, y \in \mathcal{E}.$$

The signal  $y$  is the sum of  $w$  and  $\eta$ , where  $\eta$  is the output of the process  $P(s)$ :

$$y = n + \eta, \quad \eta = P(v + u), \quad u = Ce, \quad y, n, \eta, v, u, e \in \mathcal{E}.$$

Combining these equations gives

$$\begin{aligned} e &= Fr - y = Fr - (n + \eta) = Fr - (n + P(v + u)) \\ &= Fr - (n + P(v + Ce)), \end{aligned}$$

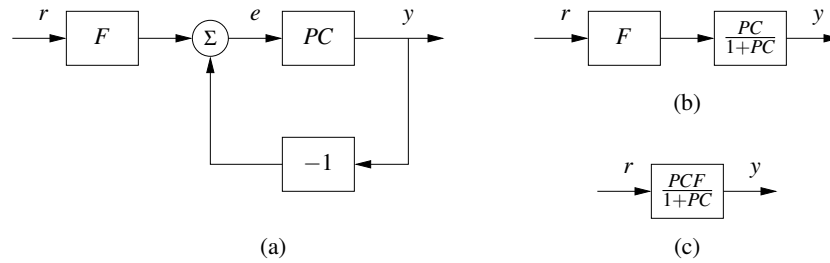

**Figure 9.9:** Example of block diagram algebra. The results from multiplying the process and controller transfer functions (from Figure 9.8) are shown in (a). Replacing the feedback loop with its transfer function equivalent yields (b), and finally multiplying the two remaining blocks gives the reference to output representation in (c).

and hence

$$e = Fr - w - Pv - PCe, \quad e, r, w, v \in \mathcal{O}.$$

Finally, solving this equation for  $e$  gives

$$e = \frac{F}{1+PC}r - \frac{1}{1+PC}w - \frac{P}{1+PC}v = G_{er}r + G_{ew}w + G_{ev}v, \quad (9.26)$$

and the error is thus the sum of three terms, depending on the reference  $r$ , the measurement noise  $w$  and the load disturbance  $v$ . The functions

$$G_{er} = \frac{F}{1+PC}, \quad G_{ew} = \frac{-1}{1+PC}, \quad G_{ev} = \frac{-P}{1+PC} \quad (9.27)$$

are transfer functions from reference  $r$ , noise  $w$  and disturbance  $v$  to the error  $e$ .

We can also derive transfer functions by manipulating the block diagrams directly, as illustrated in Figure 9.9. Suppose we wish to compute the transfer function between the reference  $r$  and the output  $y$ . We begin by combining the process and controller blocks in Figure 9.8 to obtain the diagram in Figure 9.9a. We can now eliminate the feedback loop using the algebra for a feedback interconnection (Figure 9.9b) and then use the series interconnection rule to obtain

$$G_{yr} = \frac{PCF}{1+PC}. \quad (9.28)$$

Similar manipulations can be used to obtain the other transfer functions (Exercise 9.8).

The above analysis illustrates an effective way to manipulate the equations to obtain the relations between inputs and outputs in a feedback system. The general idea is to start with the variable of interest and to trace variables backwards around the feedback loop. With some practice, equations (9.26) and (9.27) can be written directly by inspection of the block diagram. Notice, for example, that all terms in equation (9.27) have the same denominators and that the numerators are the blocks that one passes through when going directly from input to output (ignoring the feedback). This type of rule can be used to compute transfer functions by inspection, although for systems with multiple feedback loops it can be tricky

to compute them without writing down the algebra explicitly.

Next we will investigate a system with a controller based on state feedback and an observer shown in Figure 8.7. The process model is

$$\frac{dx}{dt} = Ax + Bu, \quad y = Cx,$$

and the controller (8.14) is given by

$$u = -K\hat{x} + k_r r, \quad (9.29)$$

where  $\hat{x}$  is the output of a state observer (8.15) given by

$$\frac{d\hat{x}}{dt} = A\hat{x} + Bu + L(y - C\hat{x}), \quad u = -K\hat{x} + k_r r. \quad (9.30)$$

The controller is a system with one input  $u$  and two outputs the reference  $r$  and the measured signal  $y$ . Using transfer functions and exponential signals it can be represented as

$$u = G_{ur}r + G_{uy}y, \quad u, r, y \in \mathcal{E}. \quad (9.31)$$

The transfer function,  $G_{uy}$ , from  $y$  to  $u$  describes the feedback action and,  $G_{ur}(s)$ , from  $r$  to  $u$  describes the feedforward action. We call these *open loop* transfer functions because they represent the relationships between the signals without considering the dynamics of the process (e.g., removing  $P(s)$  from the system description or cutting the loop at the process input or output). To derive the controller transfer functions we rewrite equation (9.30) as

$$\frac{d\hat{x}}{dt} = (A - BK - LC)\hat{x} + Bk_r r + Ly, \quad u = -K\hat{x} + k_r r.$$

Let  $x, r, y$  be exponential signals, the above equation gives

$$(sI - (A - BK - LC))\hat{x} = Bk_r r + Ly, \quad u = -K\hat{x} + k_r r, \quad x, r, y \in \mathcal{E},$$

and we find that the controller transfer functions in equation (9.31) are

$$G_{ur} = k_r - K(sI - BK - LC)^{-1}Bk_r, \quad G_{uy} = -K(sI - BK - LC)^{-1}L \quad (9.32)$$

We illustrated with an example.

### Example 9.10 Vehicle steering

Consider the linearized model for vehicle steering introduced in Example 6.12. In Examples 7.4 and 8.3 we designed a state feedback controller and state estimator for the system. A block diagram for the resulting control system is given in Figure 9.10. Note that we have split the estimator into two components,  $G_{\hat{x}u}(s)$  and  $G_{\hat{x}y}(s)$ , corresponding to its inputs  $u$  and  $y$ . Using the expressions for  $A, B, C$  and  $L$  from Example 8.3, it follows from equation (9.32) that

$$G_{uy}(s) = -\frac{s(k_1 l_1 + k_2 l_2) + k_1 l_2}{s^2 + s(\gamma k_1 + k_2 + l_1) + k_1 + l_2 + k_2 l_1 - \gamma k_2 l_2} = \frac{-KG_{\hat{x}y}(s)}{1 + KG_{\hat{x}u}(s)},$$

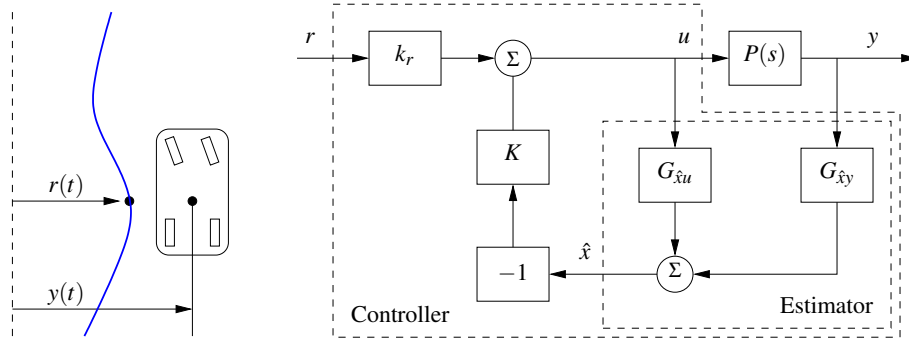

**Figure 9.10:** Block diagram for a steering control system. The control system is designed to maintain the lateral position of the vehicle along a reference curve (left). The structure of the control system is shown on the right as a block diagram of transfer functions. The estimator consists of two components that compute the estimated state  $\hat{x}$  from the combination of the input  $u$  and output  $y$  of the process. The estimated state is fed through a state feedback controller and combined with a reference gain to obtain the commanded steering angle  $u$ .

and

$$G_{ur}(s) = \frac{k_r(s^2 + l_1s + l_2)}{s^2 + s(\gamma k_1 + k_2 + l_1) + k_1 + l_2 + k_2l_1 - \gamma k_2l_2} = \frac{k_r}{1 + KG_{\hat{x}u}(s)},$$

where  $k_1$  and  $k_2$  are the state feedback gains and  $k_r$  is the reference gain. The last equalities are obtained applying block diagram algebra to Figure 9.10.

To compute the full closed loop dynamics, we begin by deriving the transfer function for the process  $P(s)$ . We can compute this directly from the state space description, which was given in Example 6.12. Using that description, we have

$$P(s) = G_{yu}(s) = C(sI - A)^{-1}B + D = \begin{pmatrix} 1 & 0 \end{pmatrix} \begin{pmatrix} s & -1 \\ 0 & s \end{pmatrix}^{-1} \begin{pmatrix} \gamma \\ 1 \end{pmatrix} = \frac{\gamma s + 1}{s^2}.$$

The transfer function for the full closed loop system between the input  $r$  and the output  $y$  is then given by

$$G_{yr} = \frac{P(s)G_{ur}(s)}{1 - P(s)G_{uy}(s)} = \frac{k_r(\gamma s + 1)}{s^2 + (k_1\gamma + k_2)s + k_1}.$$

Note that the observer gains  $l_1$  and  $l_2$  do not appear in this equation. This is because we are considering steady-state analysis and, in steady state, the estimated state exactly tracks the state of the system assuming perfect models. We will return to this example in Chapter 13 to study the robustness of this particular approach.

▽

## 9.5 The Bode Plot

The frequency response of a linear system can be computed from its transfer function by setting  $s = i\omega$ , corresponding to a complex exponential

$$u(t) = e^{i\omega t} = \cos(\omega t) + i \sin(\omega t).$$

The resulting output has the form

$$y(t) = G(i\omega)e^{i\omega t} = Me^{i(\omega t + \varphi)} = M \cos(\omega t + \varphi) + iM \sin(\omega t + \varphi),$$

where  $M$  and  $\varphi$  are the gain and phase of  $G$ :

$$M = |G(i\omega)|, \quad \varphi = \arctan \frac{\operatorname{Im} G(i\omega)}{\operatorname{Re} G(i\omega)}.$$

The phase of  $G$  is also called the *argument* of  $G$ , a term that comes from the theory of complex variables.

It follows from linearity that the response to a single sinusoid (sin or cos) is amplified by  $M$  and phase-shifted by  $\varphi$ . It will often be convenient to represent the phase in degrees rather than radians. We will use the notation  $\angle G(i\omega)$  for the phase in degrees and  $\arg G(i\omega)$  for the phase in radians. In addition, while we always take  $\arg G(i\omega)$  to be in the range  $(-\pi, \pi]$ , we will take  $\angle G(i\omega)$  to be continuous, so that it can take on values outside the range of  $-180^\circ$  to  $180^\circ$ .

The frequency response  $G(i\omega)$  can thus be represented by two curves: the gain curve and the phase curve. The *gain curve* gives  $|G(i\omega)|$  as a function of frequency  $\omega$ , and the *phase curve* gives  $\angle G(i\omega)$ . One particularly useful way of drawing these curves is to use a log/log scale for the gain plot and a log/linear scale for the phase plot. This type of plot is called a *Bode plot* and is shown in Figure 9.11.

### Sketching and Interpreting Bode Plots

Part of the popularity of Bode plots is that they are easy to sketch and interpret. Since the frequency scale is logarithmic, they cover the behavior of a linear system over a wide frequency range.

Consider a transfer function that is a rational function of the form

$$G(s) = \frac{b_1(s)b_2(s)}{a_1(s)a_2(s)}.$$

We have

$$\log |G(s)| = \log |b_1(s)| + \log |b_2(s)| - \log |a_1(s)| - \log |a_2(s)|,$$

and hence we can compute the gain curve by simply adding and subtracting gains corresponding to terms in the numerator and denominator. Similarly,

$$\angle G(s) = \angle b_1(s) + \angle b_2(s) - \angle a_1(s) - \angle a_2(s),$$

and so the phase curve can be determined in an analogous fashion. Since a poly-



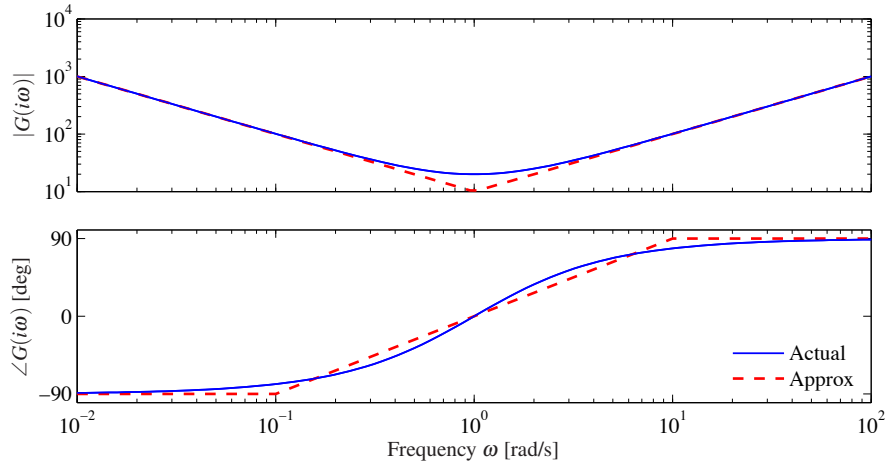

**Figure 9.11:** Bode plot of the transfer function  $C(s) = 20 + \frac{10}{s} + 10s = 10 \frac{(s+1)^2}{s}$  corresponding to an ideal PID controller. The top plot is the gain curve and the bottom plot is the phase curve. The dashed lines show straight-line approximations of the gain curve and the corresponding phase curve.

nomial can be written as a product of terms of the type

$$k, \quad s, \quad s+a, \quad s^2 + 2\zeta\omega_0s + \omega_0^2,$$

it suffices to be able to sketch Bode diagrams for these terms. The Bode plot of a complex system is then obtained by adding the gains and phases of the terms.

The function  $G(s) = s^k$  is a simple transfer function, recall that  $k = 1$  corresponds to a differentiator and  $k = -1$  to an integrator. The gain and phase of the term are given by

$$\log |G(i\omega)| = k \log \omega, \quad \angle G(i\omega) = 90k.$$

The gain curve is thus a straight line with slope  $k$ , and the phase curve is a constant at  $90^\circ \times k$ . The case when  $k = 1$  corresponds to a differentiator and has slope 1 with phase  $90^\circ$ . The case when  $k = -1$  corresponds to an integrator and has slope  $-1$  with phase  $-90^\circ$ . Bode plots of the various powers of  $k$  are shown in Figure 9.12.

Consider next the transfer function of a first-order system, given by

$$G(s) = \frac{a}{s+a}, \quad a > 0.$$

We have

$$|G(s)| = \frac{|a|}{|s+a|}, \quad \angle G(s) = \angle(a) - \angle(s+a),$$

and hence

$$\log |G(i\omega)| = \log a - \frac{1}{2} \log(\omega^2 + a^2), \quad \angle G(i\omega) = -\frac{180}{\pi} \arctan \frac{\omega}{a}.$$

The Bode plot is shown in Figure 9.13a, with the magnitude normalized by the

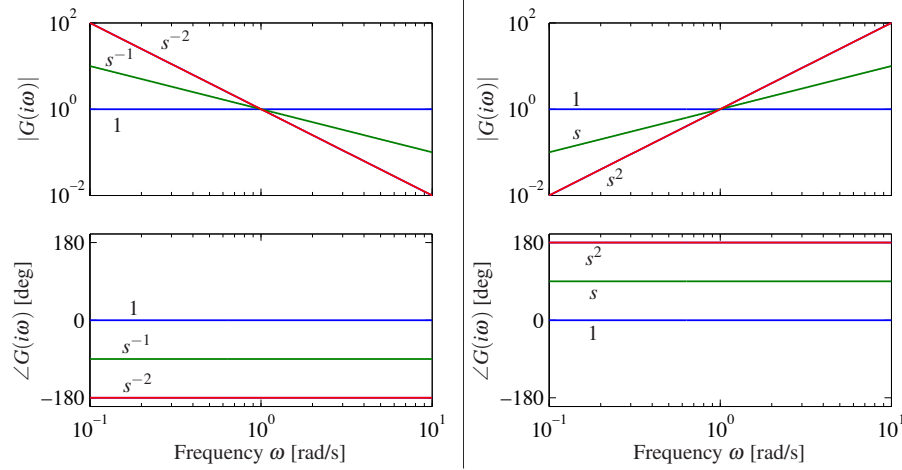

**Figure 9.12:** Bode plots of the transfer functions  $G(s) = s^k$  for  $k = -2, -1, 0, 1, 2$ . On a log-log scale, the gain curve is a straight line with slope  $k$ . The phase curves for the transfer functions are constants, with phase equal to  $90^\circ \times k$

zero frequency gain. Both the gain curve and the phase curve can be approximated by the following straight lines

$$\log |G(i\omega)| \approx \begin{cases} 0 & \text{if } \omega < a \\ \log a - \log \omega & \text{if } \omega > a, \end{cases}$$

$$\angle G(i\omega) \approx \begin{cases} 0 & \text{if } \omega < a/10 \\ -45 - 45(\log \omega - \log a) & a/10 < \omega < 10a \\ -90 & \text{if } \omega > 10a, \end{cases}$$

which intersect at  $\omega = a$ . The approximate gain curve consists of a horizontal line up to frequency  $\omega = a$ , called the *breakpoint* or *corner frequency*, after which the curve is a line of slope  $-1$  (on a log-log scale). The phase curve is zero up to frequency  $a/10$  and then decreases linearly by  $45^\circ/\text{decade}$  up to frequency  $10a$ , at which point it remains constant at  $90^\circ$ . Notice that a first-order system behaves like a constant for low frequencies and like an integrator for high frequencies; compare with the Bode plot in Figure 9.12.

Finally, consider the transfer function for a second-order system,

$$G(s) = \frac{\omega_0^2}{s^2 + 2\omega_0\zeta s + \omega_0^2},$$

for which we have

$$\log |G(i\omega)| = 2\log \omega_0 - \frac{1}{2} \log (\omega^4 + 2\omega_0^2\omega^2(2\zeta^2 - 1) + \omega_0^4),$$

$$\angle G(i\omega) = -\frac{180}{\pi} \arctan \frac{2\zeta\omega_0\omega}{\omega_0^2 - \omega^2},$$

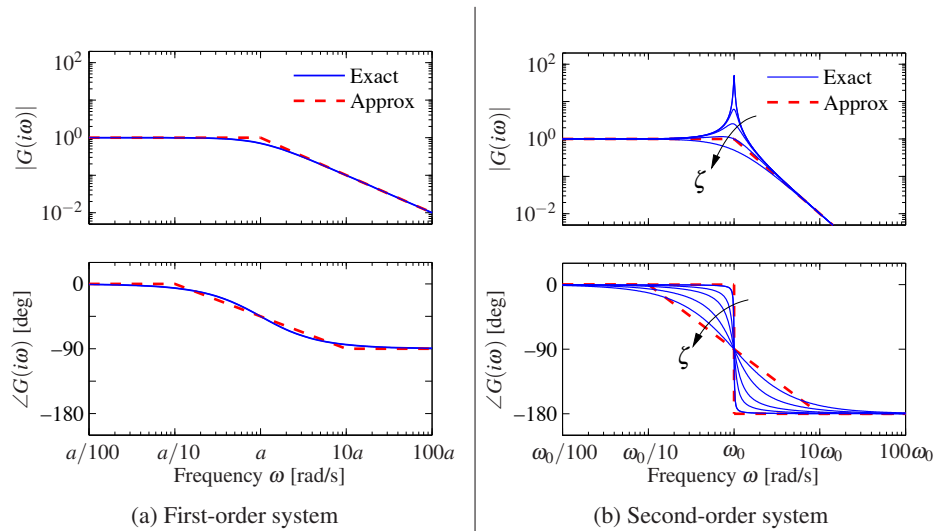

**Figure 9.13:** Bode plots for first- and second-order systems. (a) The first-order system  $G(s) = a/(s + a)$  can be approximated by asymptotic curves (dashed) in both the gain and the frequency, with the breakpoint in the gain curve at  $\omega = a$  and the phase decreasing by  $90^\circ$  over a factor of 100 in frequency. (b) The second-order system  $G(s) = \omega_0^2/(s^2 + 2\zeta\omega_0s + \omega_0^2)$  has a peak at frequency  $a$  and then a slope of  $-2$  beyond the peak; the phase decreases from  $0^\circ$  to  $-180^\circ$ . The height of the peak and the rate of change of phase depending on the damping ratio  $\zeta$  ( $\zeta = 0.02, 0.1, 0.2, 0.5$  and  $1.0$  shown).

which intersect at  $\omega = \omega_0$ . The gain curve has an asymptote with zero slope for  $\omega \ll \omega_0$ . For large values of  $\omega$  the gain curve has an asymptote with slope  $-2$ . The largest gain  $Q = \max_{\omega} |G(i\omega)| \approx 1/(2\zeta)$ , called the *Q-value*, is obtained for  $\omega \approx \omega_0$ . The phase is zero for low frequencies and approaches  $180^\circ$  for large frequencies. The curves can be approximated with the following piecewise linear expressions

$$\log |G(i\omega)| \approx \begin{cases} 0 & \text{if } \omega \ll \omega_0 \\ 2 \log \omega_0 - 2 \log \omega & \text{if } \omega \gg \omega_0, \end{cases}$$

$$\angle G(i\omega) \approx \begin{cases} 0 & \text{if } \omega \ll \omega_0 \\ -180 & \text{if } \omega \gg \omega_0. \end{cases}$$

The Bode plot is shown in Figure 9.13b. Note that the asymptotic approximation is poor near  $\omega = \omega_0$  and that the Bode plot depends strongly on  $\zeta$  near this frequency.

Given the Bode plots of the basic functions, we can now sketch the frequency response for a more general system. The following example illustrates the basic idea.

#### Example 9.11 Asymptotic approximation for a transfer function

Consider the transfer function given by

$$G(s) = \frac{k(s+b)}{(s+a)(s^2 + 2\zeta\omega_0s + \omega_0^2)}, \quad a \ll b \ll \omega_0.$$

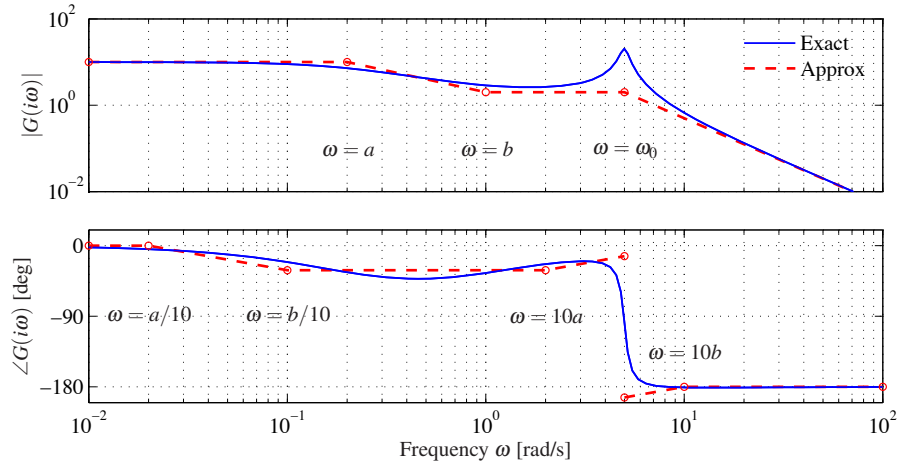

**Figure 9.14:** Asymptotic approximation to a Bode plot. The thin line is the Bode plot for the transfer function  $G(s) = k(s+b)/(s+a)(s^2 + 2\zeta\omega_0s + \omega_0^2)$ , where  $a \ll b \ll \omega_0$ . Each segment in the gain and phase curves represents a separate portion of the approximation, where either a pole or a zero begins to have effect. Each segment of the approximation is a straight line between these points at a slope given by the rules for computing the effects of poles and zeros.

The Bode plot for this transfer function appears in Figure 9.14, with the complete transfer function shown as a solid line and the asymptotic approximation shown as a dashed line.

We begin with the gain curve. At low frequency, the magnitude is given by

$$G(0) = \frac{kb}{a\omega_0^2}.$$

When we reach  $\omega = a$ , the effect of the pole begins and the gain decreases with slope  $-1$ . At  $\omega = b$ , the zero comes into play and we increase the slope by 1, leaving the asymptote with net slope 0. This slope is used until the effect of the second-order pole is seen at  $\omega = \omega_0$ , at which point the asymptote changes to slope  $-2$ . We see that the gain curve is fairly accurate except in the region of the peak due to the second-order pole (since for this case  $\zeta$  is reasonably small).

The phase curve is more complicated since the effect of the phase stretches out much further. The effect of the pole begins at  $\omega = a/10$ , at which point we change from phase 0 to a slope of  $-45^\circ/\text{decade}$ . The zero begins to affect the phase at  $\omega = b/10$ , producing a flat section in the phase. At  $\omega = 10a$  the phase contributions from the pole end, and we are left with a slope of  $+45^\circ/\text{decade}$  (from the zero). At the location of the second-order pole,  $s \approx i\omega_0$ , we get a jump in phase of  $-180^\circ$ . Finally, at  $\omega = 10b$  the phase contributions of the zero end, and we are left with a phase of  $-180$  degrees. We see that the straight-line approximation for the phase is not as accurate as it was for the gain curve, but it does capture the basic features of the phase changes as a function of frequency.  $\nabla$

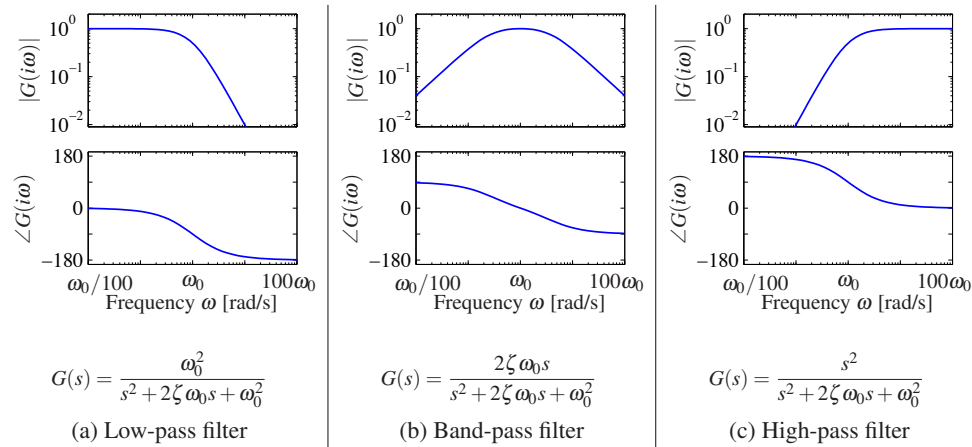

**Figure 9.15:** Bode plots for low-pass, band-pass and high-pass filters. The top plots are the gain curves and the bottom plots are the phase curves. Each system passes frequencies in a different range and attenuates frequencies outside of that range.

The Bode plot gives a quick overview of a system. Since any signal can be decomposed into a sum of sinusoids, it is possible to visualize the behavior of a system for different frequency ranges. The system can be viewed as a filter that can change the amplitude (and phase) of the input signals according to the frequency response. For example, if there are frequency ranges where the gain curve has constant slope and the phase is close to zero, the action of the system for signals with these frequencies can be interpreted as a pure gain. Similarly, for frequencies where the slope is  $+1$  and the phase close to  $90^\circ$ , the action of the system can be interpreted as a differentiator, as shown in Figure 9.12.

Three common types of frequency responses are shown in Figure 9.15. The system in Figure 9.15a is called a *low-pass filter* because the gain is constant for low frequencies and drops for high frequencies. Notice that the phase is zero for low frequencies and  $-180^\circ$  for high frequencies. The systems in Figure 9.15b and c are called a *band-pass filter* and *high-pass filter* for similar reasons.

To illustrate how different system behaviors can be read from the Bode plots we consider the band-pass filter in Figure 9.15b. For frequencies around  $\omega = \omega_0$ , the signal is passed through with no change in gain. However, for frequencies well below or well above  $\omega_0$ , the signal is attenuated. The phase of the signal is also affected by the filter, as shown in the phase curve. For frequencies below  $\omega_0/100$  there is a phase lead of  $90^\circ$ , and for frequencies above  $100\omega_0$  there is a phase lag of  $90^\circ$ . These actions correspond to differentiation and integration of the signal in these frequency ranges.

### Example 9.12 Transcriptional regulation

Consider a genetic circuit consisting of a single gene. We wish to study the response of the protein concentration to fluctuations in the mRNA dynamics. We consider two cases: a *constitutive promoter* (no regulation) and self-repression

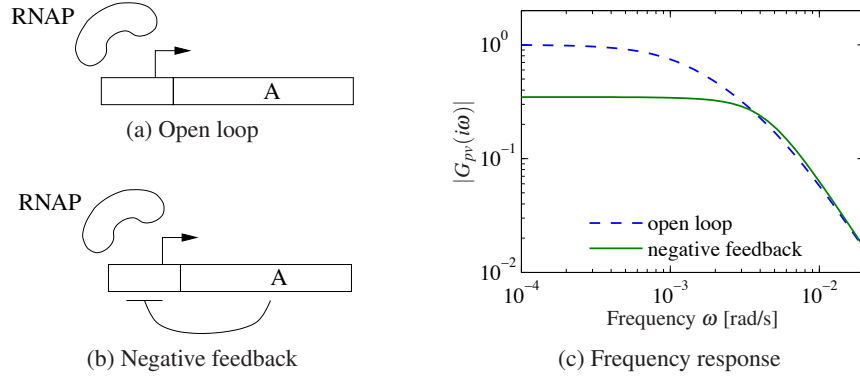

**Figure 9.16:** Noise attenuation in a genetic circuit. The open loop system (a) consists of a constitutive promoter, while the closed loop circuit (b) is self-regulated with negative feedback (repressor). The frequency response for each circuit is shown in (c).

(negative feedback), illustrated in Figure 9.16. The dynamics of the system are given by

$$\frac{dm}{dt} = \alpha(p) - \gamma m - v, \quad \frac{dp}{dt} = \beta m - \delta p,$$

where  $v$  is a disturbance term that affects mRNA transcription.

For the case of no feedback we have  $\alpha(p) = \alpha_0$ , and when  $u = 0$  the system has an equilibrium point at  $m_e = \alpha_0/\gamma$ ,  $p_e = \beta\alpha_0/(\delta\gamma)$ . The open loop transfer function from  $v$  to  $p$  is given by

$$G_{pv}^{\text{ol}}(s) = \frac{-\beta}{(s + \gamma)(s + \delta)}.$$

For the case of negative regulation, we have

$$\alpha(p) = \frac{\alpha_1}{1 + kp^n} + \alpha_0,$$

and the equilibrium points satisfy

$$m_e = \frac{\delta}{\beta} p_e, \quad \frac{\alpha}{1 + kp_e^n} + \alpha_0 = \gamma m_e = \frac{\gamma\delta}{\beta} p_e.$$

The resulting transfer function is given by

$$G_{pv}^{\text{cl}}(s) = \frac{\beta}{(s + \gamma)(s + \delta) + \beta\sigma}, \quad \sigma = \frac{n\alpha_1 kp_e^{n-1}}{(1 + kp_e^n)^2}.$$

Figure 9.16c shows the frequency response for the two circuits. We see that the feedback circuit attenuates the response of the system to disturbances with low-frequency content but slightly amplifies disturbances at high frequency (compared to the open loop system). Notice that these curves are very similar to the frequency response curves for the op amp shown in Figure 9.3.  $\nabla$

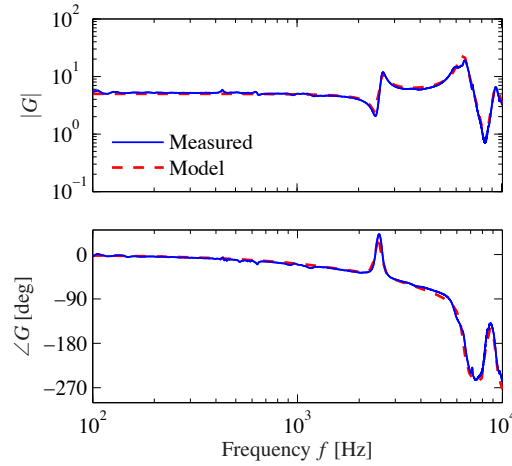

**Figure 9.17:** Frequency response of a preloaded piezoelectric drive for an atomic force microscope. The Bode plot shows the response of the measured transfer function (solid) and the fitted transfer function (dashed).

### Transfer Functions from Experiments

The transfer function of a system provides a summary of the input/output response and is very useful for analysis and design. Fortunately, we can often build an input/output model for a given application by directly measuring the frequency response and fitting a transfer function to it. To do so, we perturb the input to the system using a sinusoidal signal at a fixed frequency. When steady state is reached, the amplitude ratio and the phase lag give the frequency response for the excitation frequency. The complete frequency response is obtained by sweeping over a range of frequencies.

By using correlation techniques it is possible to determine the frequency response very accurately, and an analytic transfer function can be obtained from the frequency response by curve fitting. The success of this approach has led to instruments and software that automate this process, called *spectrum analyzers*. We illustrate the basic concept through two examples.

#### Example 9.13 Atomic force microscope

To illustrate the utility of spectrum analysis, we consider the dynamics of the atomic force microscope, described in Section 4.5. Experimental determination of the frequency response is particularly attractive for this system because its dynamics are very fast and hence experiments can be done quickly. A typical example is given in Figure 9.17, which shows an experimentally determined frequency response (solid line). In this case the frequency response was obtained in less than a second. The transfer function

$$G(s) = \frac{k\omega_2^2\omega_3^2\omega_5^2(s^2 + 2\zeta_1\omega_1s + \omega_1^2)(s^2 + 2\zeta_4\omega_4s + \omega_4^2)e^{-s\tau}}{\omega_1^2\omega_4^2(s^2 + 2\zeta_2\omega_2s + \omega_2^2)(s^2 + 2\zeta_3\omega_3s + \omega_3^2)(s^2 + 2\zeta_5\omega_5s + \omega_5^2)},$$

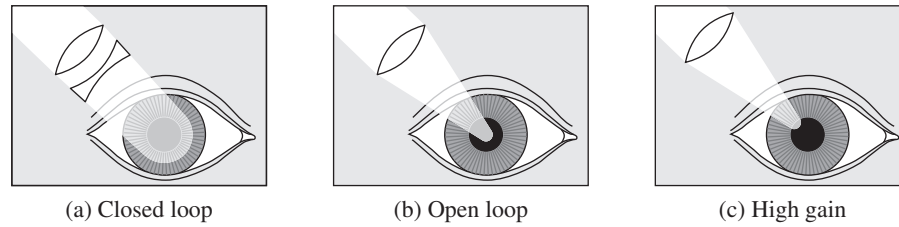

**Figure 9.18:** Light stimulation of the eye. In (a) the light beam is so large that it always covers the whole pupil, giving closed loop dynamics. In (b) the light is focused into a beam which is so narrow that it is not influenced by the pupil opening, giving open loop dynamics. In (c) the light beam is focused on the edge of the pupil opening, which has the effect of increasing the gain of the system since small changes in the pupil opening have a large effect on the amount of light entering the eye. From Stark [Sta68].

with  $\omega_k = 2\pi f_k$  and  $f_1 = 2.42$  kHz,  $\zeta_1 = 0.03$ ,  $f_2 = 2.55$  kHz,  $\zeta_2 = 0.03$ ,  $f_3 = 6.45$  kHz,  $\zeta_3 = 0.042$ ,  $f_4 = 8.25$  kHz,  $\zeta_4 = 0.025$ ,  $f_5 = 9.3$  kHz,  $\zeta_5 = 0.032$ ,  $\tau = 10^{-4}$  s and  $k = 5$ , was fitted to the data (dashed line). The frequencies  $\omega_1$  and  $\omega_4$  associated with the zeros are located where the gain curve has minima, and the frequencies  $\omega_2$ ,  $\omega_3$  and  $\omega_5$  associated with the poles are located where the gain curve has local maxima. The relative damping ratios are adjusted to give a good fit to maxima and minima. When a good fit to the gain curve is obtained, the time delay is adjusted to give a good fit to the phase curve. The piezo drive is preloaded, and a simple model of its dynamics is derived in Exercise 4.7. The pole at 2.55kHz corresponds to the trampoline mode derived in the exercise; the other resonances are higher modes.

▽

### Example 9.14 Pupillary light reflex dynamics

The human eye is an organ that is easily accessible for experiments. It has a control system that adjusts the pupil opening to regulate the light intensity at the retina.

This control system was explored extensively by Stark in the 1960s [Sta68]. To determine the dynamics, light intensity on the eye was varied sinusoidally and the pupil opening was measured. A fundamental difficulty is that the closed loop system is insensitive to internal system parameters, so analysis of a closed loop system thus gives little information about the internal properties of the system. Stark used a clever experimental technique that allowed him to investigate both open and closed loop dynamics. He excited the system by varying the intensity of a light beam focused on the eye and measured pupil area, as illustrated in Figure 9.18. By using a wide light beam that covers the whole pupil, the measurement gives the closed loop dynamics. The open loop dynamics were obtained by using a narrow beam, which is small enough that it is not influenced by the pupil opening. The result of one experiment for determining open loop dynamics is given in Figure 9.19. Fitting a transfer function to the gain curve gives a good fit for  $G(s) = 0.17/(1 + 0.08s)^3$ . This curve gives a poor fit to the phase curve as shown by the dashed curve in Figure 9.19. The fit to the phase curve is improved by



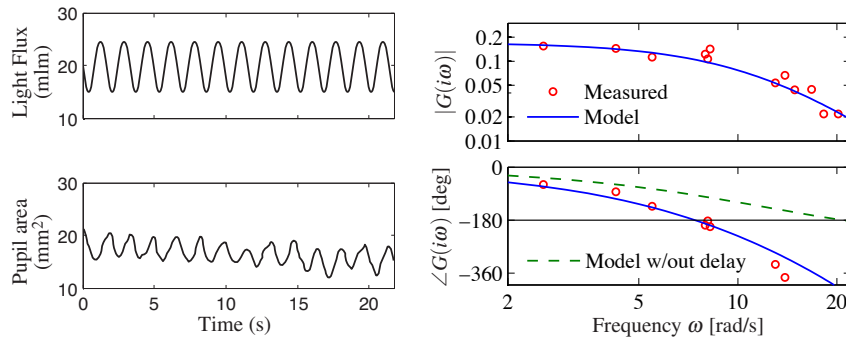

**Figure 9.19:** Sample curves from an open loop frequency response of the eye (left) and a Bode plot for the open loop dynamics (right). The solid curve shows a fit of the data using a third-order transfer function with time delay. The dashed curve in the Bode plot is the phase of the system without time delay, showing that the delay is needed to properly capture the phase. (Figure redrawn from the data of Stark [Sta68].)

adding a  $0.2s$  time delay, which leaves the gain curve unchanged while substantially modifying the phase curve. The final fit gives the model

$$G(s) = \frac{0.17}{(1 + 0.08s)^3} e^{-0.2s}.$$

The Bode plot of this is shown with solid curves in Figure 9.19. Modeling of the pupillary reflex from first principles is discussed in detail in [KS01].  $\nabla$

Notice that for both the AFM drive and pupillary dynamics it is not easy to derive appropriate models from first principles. In practice, it is often fruitful to use a combination of analytical modeling and experimental identification of parameters. Experimental determination of frequency response is less attractive for systems with slow dynamics because the experiment takes a long time.

## 9.6 Further Reading

The idea of characterizing a linear system by its steady-state response to sinusoids was introduced by Fourier in his investigation of heat conduction in solids [Fou07]. Much later, it was used by the electrical engineer Steinmetz who introduced the  $i\omega$  method for analyzing electrical circuits. Transfer functions were introduced via the Laplace transform by Gardner Barnes [GB42], who also used them to calculate the response of linear systems. The Laplace transform was very important in the early phase of control because it made it possible to find transients via tables (see, e.g., [JNP47]). Combined with block diagrams, transfer functions and Laplace transforms provided powerful techniques for dealing with complex systems. Calculation of responses based on Laplace transforms is less important today, when responses of linear systems can easily be generated using computers. There are many excellent books on the use of Laplace transforms and transfer functions for

modeling and analysis of linear input/output systems. Traditional texts on control such as [DB04], [FPEN05] and [Oga01] are representative examples. Pole/zero cancellation was one of the mysteries of early control theory. It is clear that common factors can be canceled in a rational function, but cancellations have system theoretical consequences that were not clearly understood until Kalman's decomposition of a linear system was introduced [KHN63]. In the following chapters, we will use transfer functions extensively to analyze stability and to describe model uncertainty.

## Exercises

**9.1** Let  $G(s)$  be the transfer function for a linear system. Show that if we apply an input  $u(t) = A \sin(\omega t)$ , then the steady-state output is given by  $y(t) = |G(i\omega)|A \sin(\omega t + \arg G(i\omega))$ . (Hint: Start by showing that the real part of a complex number is a linear operation and then use this fact.)

**9.2** Consider the system

$$\frac{dx}{dt} = ax + u.$$

Compute the exponential response of the system and use this to derive the transfer function from  $u$  to  $x$ . Show that when  $s = a$ , a pole of the transfer function, the response to the exponential input  $u(t) = e^{st}$  is  $x(t) = e^{at}x(0) + te^{at}$ .

**9.3** (Inverted pendulum) A model for an inverted pendulum was introduced in Example 3.2. Neglecting damping and linearizing the pendulum around the upright position gives a linear system characterized by the matrices

$$A = \begin{pmatrix} 0 & 1 \\ mgl/J_t & 0 \end{pmatrix}, \quad B = \begin{pmatrix} 0 \\ 1/J_t \end{pmatrix}, \quad C = \begin{pmatrix} 1 & 0 \end{pmatrix}, \quad D = 0.$$

Determine the transfer function of the system.

**9.4** (Solutions corresponding to poles and zeros) Consider the differential equation

$$\frac{d^n y}{dt^n} + a_1 \frac{d^{n-1} y}{dt^{n-1}} + \cdots + a_n y = b_1 \frac{d^{n-1} u}{dt^{n-1}} + b_2 \frac{d^{n-2} u}{dt^{n-2}} + \cdots + b_n u.$$

(a) Let  $\lambda$  be a root of the characteristic polynomial

$$s^n + a_1 s^{n-1} + \cdots + a_n = 0.$$

Show that if  $u(t) = 0$ , the differential equation has the solution  $y(t) = e^{\lambda t}$ .

(b) Let  $\kappa$  be a zero of the polynomial

$$b(s) = b_1 s^{n-1} + b_2 s^{n-2} + \cdots + b_n.$$

Show that if the input is  $u(t) = e^{\kappa t}$ , then there is a solution to the differential equation that is identically zero.

**9.5** (Operational amplifier) Consider the operational amplifier described in Section 4.3 and analyzed in Example 9.3. A PI controller can be constructed using an op amp by replacing the resistor  $R_2$  with a resistor and capacitor in series, as shown in Figure 4.10. The resulting transfer function of the circuit is given by

$$G(s) = - \left( R_2 + \frac{1}{Cs} \right) \cdot \left( \frac{kCs}{((k+1)R_1C + R_2C)s + 1} \right),$$

where  $k$  is the gain of the op amp,  $R_1$  and  $R_2$  are the resistances in the compensation network and  $C$  is the capacitance.

(a) Sketch the Bode plot for the system under the assumption that  $k \gg R_2 > R_1$ . You should label the key features in your plot, including the gain and phase at low frequency, the slopes of the gain curve, the frequencies at which the gain changes slope, etc.

(b) Suppose now that we include some dynamics in the amplifier, as outlined in Example 8.1. This would involve replacing the gain  $k$  with the transfer function

$$H(s) = \frac{k}{1 + sT}.$$

Compute the resulting transfer function for the system (i.e., replace  $k$  with  $H(s)$ ) and find the poles and zeros assuming the following parameter values

$$\frac{R_2}{R_1} = 100, \quad k = 10^6, \quad R_2C = 1, \quad T = 0.01.$$

(c) Sketch the Bode plot for the transfer function in part (b) using straight line approximations and compare this to the exact plot of the transfer function (using MATLAB). Make sure to label the important features in your plot.

**9.6** (Transfer function for state space system) Consider the linear state space system

$$\frac{dx}{dt} = Ax + Bu, \quad y = Cx.$$

(a) Show that the transfer function is

$$G(s) = \frac{b_1s^{n-1} + b_2s^{n-2} + \cdots + b_n}{s^n + a_1s^{n-1} + \cdots + a_n},$$

where

$$b_1 = CB, \quad b_2 = CAB + a_1CB, \quad \dots, \quad b_n = CA^{n-1}B + a_1CA^{n-2}B + \cdots + a_{n-1}CB$$

and  $\lambda(s) = s^n + a_1s^{n-1} + \cdots + a_n$  is the characteristic polynomial for  $A$ .

(b) Compute the transfer function for a linear system in reachable canonical form and show that it matches the transfer function given above.

**9.7** (Kalman decomposition) Show that the transfer function of a system depends only on the dynamics in the reachable and observable subspace of the Kalman decomposition. (Hint: Consider the representation given by equation (8.27).) 

**9.8** Using block diagram algebra, show that the transfer functions from  $v$  to  $y$  and  $w$  to  $y$  in Figure 9.8 are given by

$$G_{yv} = \frac{P}{1+PC} \quad G_{yw} = \frac{1}{1+PC}.$$

**9.9** (Bode plot for a simple zero) Show that the Bode plot for transfer function  $G(s) = (s+a)/a$  can be approximated by

$$\log |G(i\omega)| \approx \begin{cases} 0 & \text{if } \omega < a \\ \log \omega - \log a & \text{if } \omega > a, \end{cases}$$

$$\angle G(i\omega) \approx \begin{cases} 0 & \text{if } \omega < a/10 \\ 45 + 45(\log \omega - \log a) & a/10 < \omega < 10a \\ 90 & \text{if } \omega > 10a. \end{cases}$$

**9.10** (Vectored thrust aircraft) Consider the lateral dynamics of a vectored thrust aircraft as described in Example 3.11. Show that the dynamics can be described using the following block diagram:

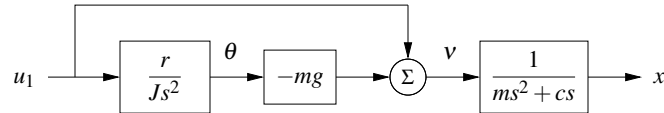

Use this block diagram to compute the transfer functions from  $u_1$  to  $\theta$  and  $x$  and show that they satisfy

$$H_{\theta u_1} = \frac{r}{Js^2}, \quad H_{xu_1} = \frac{Js^2 - mgr}{Js^2(ms^2 + cs)}.$$



**9.11** (Common poles) Consider a closed loop system of the form of Figure 9.8, with  $F = 1$  and  $P$  and  $C$  having a pole/zero cancellation. Show that if each system is written in state space form, the resulting closed loop system is not reachable and not observable.

**9.12** (Congestion control) Consider the congestion control model described in Section 4.4. Let  $w$  represent the individual window size for a set of  $N$  identical sources,  $q$  represent the end-to-end probability of a dropped packet,  $b$  represent the number of packets in the router's buffer and  $p$  represent the probability that a packet is dropped by the router. We write  $\bar{w} = Nw$  to represent the total number of packets being received from all  $N$  sources. Show that the linearized model can be described

by the transfer functions

$$G_{b\bar{w}}(s) = \frac{e^{-\tau_f s}}{\tau_e s + e^{-\tau_f s}}, \quad G_{\bar{w}q}(s) = -\frac{N}{q_e(\tau_e s + q_e w_e)}, \quad G_{pb}(s) = \rho,$$

where  $(w_e, b_e)$  is the equilibrium point for the system,  $\tau_e$  is the steady-state round-trip time and  $\tau_f$  is the forward propagation time.

**9.13** (Inverted pendulum with PD control) Consider the normalized inverted pendulum system, whose transfer function is given by  $P(s) = 1/(s^2 - 1)$  (Exercise 9.3). A proportional-derivative control law for this system has transfer function  $C(s) = k_p + k_d s$  (see Table 9.1). Suppose that we choose  $C(s) = \alpha(s - 1)$ . Compute the closed loop dynamics and show that the system has good tracking of reference signals but does not have good disturbance rejection properties.

**9.14** (Vehicle suspension [HB90]) Active and passive damping are used in cars to give a smooth ride on a bumpy road. A schematic diagram of a car with a damping system is shown in the figure below.



(Porter Class I race car driven by Todd Cuffaro)

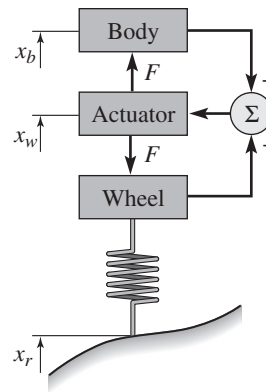

This model is called a *quarter car model*, and the car is approximated with two masses, one representing one fourth of the car body and the other a wheel. The actuator exerts a force  $F$  between the wheel and the body based on feedback from the distance between the body and the center of the wheel (the *rattle space*).

Let  $x_b$ ,  $x_w$  and  $x_r$  represent the heights of body, wheel and road measured from their equilibria. A simple model of the system is given by Newton's equations for the body and the wheel,

$$m_b \ddot{x}_b = F, \quad m_w \ddot{x}_w = -F + k_t(x_r - x_w),$$

where  $m_b$  is a quarter of the body mass,  $m_w$  is the effective mass of the wheel including brakes and part of the suspension system (the *unsprung mass*) and  $k_t$  is the tire stiffness. For a conventional damper consisting of a spring and a damper, we have  $F = k(x_w - x_b) + c(\dot{x}_w - \dot{x}_b)$ . For an active damper the force  $F$  can be more general and can also depend on riding conditions. Rider comfort can be characterized by the transfer function  $G_{ax_r}$  from road height  $x_r$  to body acceleration  $a = \ddot{x}_b$ . Show that this transfer function has the property  $G_{ax_r}(i\omega_t) = k_t/m_b$ ,

where  $\omega_t = \sqrt{k_t/m_w}$  (the *tire hop frequency*). The equation implies that there are fundamental limitations to the comfort that can be achieved with any damper.

**9.15** (Vibration absorber) Damping vibrations is a common engineering problem. A schematic diagram of a damper is shown below:

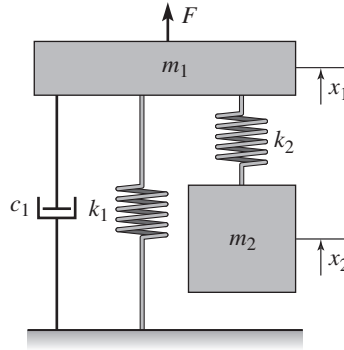

The disturbing vibration is a sinusoidal force acting on mass  $m_1$ , and the damper consists of the mass  $m_2$  and the spring  $k_2$ . Show that the transfer function from disturbance force to height  $x_1$  of the mass  $m_1$  is

$$G_{x_1 F} = \frac{m_2 s^2 + k_2}{m_1 m_2 s^4 + m_2 c_1 s^3 + (m_1 k_2 + m_2 (k_1 + k_2)) s^2 + k_2 c_1 s + k_1 k_2}.$$

How should the mass  $m_2$  and the stiffness  $k_2$  be chosen to eliminate a sinusoidal oscillation with frequency  $\omega_0$ . (More details are vibration absorbers is given in the classic text by Den Hartog [DH85, pp. 87–93].)

---

## Chapter Ten

### Frequency Domain Analysis

*Mr. Black proposed a negative feedback repeater and proved by tests that it possessed the advantages which he had predicted for it. In particular, its gain was constant to a high degree, and it was linear enough so that spurious signals caused by the interaction of the various channels could be kept within permissible limits. For best results the feedback factor  $\mu\beta$  had to be numerically much larger than unity. The possibility of stability with a feedback factor larger than unity was puzzling.*

Harry Nyquist, "The Regeneration Theory," 1956 [Nyq56].

In this chapter we study how the stability and robustness of closed loop systems can be determined by investigating how sinusoidal signals of different frequencies propagate around the feedback loop. This technique allows us to reason about the *closed loop behavior* of a system through the *frequency domain* properties of the *open loop* transfer function. The Nyquist stability theorem is a key result that provides a way to analyze stability and introduce measures of degrees of stability.

#### 10.1 The Loop Transfer Function

Understanding how the behavior of a closed loop system is influenced by the properties of its open loop is tricky. Indeed, as the quote from Nyquist above illustrates, the behavior of feedback systems can often be puzzling. However, using the mathematical framework of transfer functions provides an elegant way to reason about such systems, which we call *loop analysis*.

The basic idea of loop analysis is to trace how a sinusoidal signal propagates in the feedback loop and explore the resulting stability by investigating if the propagated signal grows or decays. This is easy to do because the transmission of sinusoidal signals through a linear dynamical system is characterized by the frequency response of the system. The key result is the Nyquist stability theorem, which provides a great deal of insight regarding the stability of a system. Unlike proving stability with Lyapunov functions, studied in Chapter 5, the Nyquist criterion allows us to determine more than just whether a system is stable or unstable. It provides a measure of the degree of stability through the definition of stability margins. The Nyquist theorem also indicates how an unstable system should be changed to make it stable, which we shall study in detail in Chapters 11–13.

Consider the system in Figure 10.1a. The traditional way to determine if the closed loop system is stable is to investigate if the closed loop characteristic polynomial has all its roots in the left half-plane. If the process and the controller have rational transfer functions  $P(s) = n_p(s)/d_p(s)$  and  $C(s) = n_c(s)/d_c(s)$ , then the

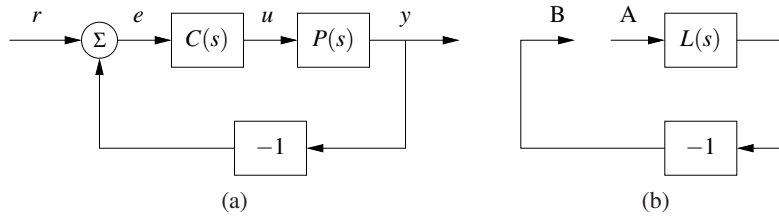

**Figure 10.1:** The loop transfer function. The stability of the feedback system (a) can be determined by tracing signals around the loop. Letting  $L = PC$  represent the loop transfer function, we break the loop in (b) and ask whether a signal injected at the point A has the same magnitude and phase when it reaches point B.

closed loop system has the transfer function

$$G_{yr}(s) = \frac{PC}{1 + PC} = \frac{n_p(s)n_c(s)}{d_p(s)d_c(s) + n_p(s)n_c(s)},$$

and the characteristic polynomial is

$$\lambda(s) = d_p(s)d_c(s) + n_p(s)n_c(s).$$

To check stability, we simply compute the roots of the characteristic polynomial and verify that they each have negative real part. This approach is straightforward but it gives little guidance for design: it is not easy to tell how the controller should be modified to make an unstable system stable.

Nyquist's idea was to first investigate conditions under which oscillations can occur in a feedback loop. To study this, we introduce the *loop transfer function*  $L(s) = P(s)C(s)$ , which is the transfer function obtained by breaking the feedback loop, as shown in Figure 10.1b. The loop transfer function is simply the transfer function from the input at position A to the output at position B multiplied by  $-1$  (to account for the usual convention of negative feedback).

Assume that a sinusoid of frequency  $\omega_0$  is injected at point A. In steady state the signal at point B will also be a sinusoid with the frequency  $\omega_0$ . It seems reasonable that an oscillation can be maintained if the signal at B has the same amplitude and phase as the injected signal because we can then disconnect the injected signal and connect A to B. Tracing signals around the loop, we find that the signals at A and B are identical if there is a frequency  $\omega_0$  such that

$$L(i\omega_c) = -1, \tag{10.1}$$

which then provides a condition for maintaining an oscillation. The condition (10.1) implies that the Nyquist plot of the loop transfer function goes through the point  $L = -1$ , which is called the *critical point*. Let  $\omega_c$  represent a frequency at which  $\angle L(i\omega_c) = 180^\circ$ . Intuitively it seems reasonable that the system is stable if  $|L(i\omega_c)| < 1$ , which means that the signal at point B will have smaller amplitude than the injected signal. This is essentially true, but there are several subtleties that require a proper mathematical analysis leading to Nyquist's stability criterion.



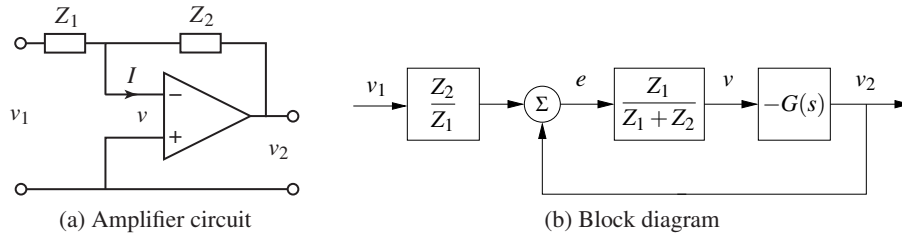

**Figure 10.2:** Loop transfer function for an op amp. The op amp circuit (a) has a nominal transfer function  $v_2/v_1 = Z_2(s)/Z_1(s)$ , where  $Z_1$  and  $Z_2$  are the impedances of the circuit elements. The system can be represented by its block diagram (b), where we now include the op amp dynamics  $G(s)$ . The loop transfer function is  $L = Z_1G/(Z_1 + Z_2)$ .

### Example 10.1 Operational amplifier circuit

Consider the op amp circuit in Figure 10.2a, where  $Z_1$  and  $Z_2$  are the transfer functions of the feedback elements from voltage to current. There is feedback because voltage  $v_2$  is related to voltage  $v$  through the transfer function  $-G$  describing the op amp dynamics and voltage  $v$  is related to voltage  $v_2$  through the transfer function  $Z_1/(Z_1 + Z_2)$ . The loop transfer function is thus

$$L = \frac{GZ_1}{Z_1 + Z_2}. \quad (10.2)$$

Assuming that the current  $I$  is zero, the current through the elements  $Z_1$  and  $Z_2$  is the same, which implies

$$\frac{v_1 - v}{Z_1} = \frac{v - v_2}{Z_2}.$$

Solving for  $v$  gives

$$v = \frac{Z_2 v_1 + Z_1 v_2}{Z_1 + Z_2} = \frac{Z_2 v_1 - Z_1 G v}{Z_1 + Z_2} = \frac{Z_2}{Z_1} \frac{L}{G} v_1 - L v.$$

Hence

$$v = \frac{L}{G(1 + L)} v_1.$$

Since  $v_2 = -Gv$  the input/output relation for the circuit is then described by the transfer function

$$G_{v_2 v_1} = -\frac{Z_2}{Z_1} \frac{L}{1 + L}.$$

A block diagram is shown in Figure 10.2b. It follows from (10.1) that the condition for oscillation of the op amp circuit is

$$L(i\omega) = \frac{Z_1(i\omega)G(i\omega)}{Z_1(i\omega) + Z_2(i\omega)} = -1 \quad (10.3)$$

▽

One of the powerful concepts embedded in Nyquist's approach to stability analysis is that it allows us to study the stability of the feedback system by looking at

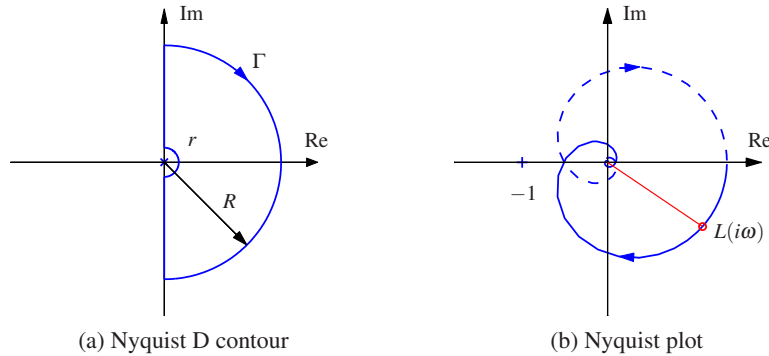

**Figure 10.3:** The Nyquist contour  $\Gamma$  and the Nyquist plot. The Nyquist contour (a) encloses the right half-plane, with a small semicircle around any poles of  $L(s)$  at the origin or on the imaginary axis (illustrated here at the origin) and an arc whose radius  $R$  extends towards  $\infty$ . The Nyquist plot (b) is the image of the loop transfer function  $L(s)$  when  $s$  traverses  $\Gamma$  in the clockwise direction. The solid line corresponds to  $\omega > 0$ , and the dashed line to  $\omega < 0$ . The gain and phase at the frequency  $\omega$  are  $g = |L(i\omega)|$  and  $\varphi = \angle L(i\omega)$ . The curve is generated for  $L(s) = 1.4e^{-s}/(s+1)^2$ .

properties of the loop transfer function. The advantage of doing this is that it is easy to see how the controller should be chosen to obtain a desired loop transfer function. For example, if we change the gain of the controller, the loop transfer function will be scaled accordingly and the critical point is avoided. A simple way to stabilize an unstable system is to reduce the gain or to modify the controller so that the critical point  $-1$  is avoided. Different ways to do this, called loop shaping, will be developed and will be discussed in Chapter 12.

## 10.2 The Nyquist Criterion

In this section we present Nyquist's criterion for determining the stability of a feedback system through analysis of the loop transfer function. We begin by introducing a convenient graphical tool, the Nyquist plot, and show how it can be used to ascertain stability.

### The Nyquist Plot

We saw in the previous chapter that the dynamics of a linear system can be represented by its frequency response and graphically illustrated by a Bode plot. To study the stability of a system, we will make use of a different representation of the frequency response called a *Nyquist plot*. The Nyquist plot of the loop transfer function  $L(s)$  is formed by tracing  $s \in \mathbb{C}$  around the Nyquist “D contour,” consisting of the imaginary axis combined with an arc at infinity connecting the endpoints of the imaginary axis. The contour, denoted as  $\Gamma \in \mathbb{C}$ , is illustrated in Figure 10.3a. The image of  $L(s)$  when  $s$  traverses  $\Gamma$  gives a closed curve in the complex plane and is referred to as the Nyquist plot for  $L(s)$ , as shown in Figure 10.3b. Note that

if the transfer function  $L(s)$  goes to zero as  $s$  gets large (the usual case), then the portion of the contour “at infinity” maps to the origin. Furthermore, the portion of the plot corresponding to  $\omega < 0$  is the mirror image of the portion with  $\omega > 0$ .

There is a subtlety in the Nyquist plot when the loop transfer function has poles on the imaginary axis because the gain is infinite at the poles. To solve this problem, we modify the contour  $\Gamma$  to include small deviations that avoid any poles on the imaginary axis, as illustrated in Figure 10.3a (assuming a pole of  $L(s)$  at the origin). The deviation consists of a small semicircle to the right of the imaginary axis pole location.

When the loop transfer function has no poles in the right half plane the Nyquist stability criterion is.

**Theorem 10.1** (Simplified Nyquist criterion). *Let  $L(s)$  be the loop transfer function for a negative feedback system (as shown in Figure 10.1a) and assume that  $L$  has no poles in the open right half-plane ( $\text{Re } s \geq 0$ ). Then the closed loop system is stable if and only if the closed contour given by  $\Omega = \{L(i\omega) : -\infty < \omega < \infty\} \subset \mathbb{C}$  has no net encirclements of the critical point  $s = -1$ .*

The following conceptual procedure can be used to determine that there are no encirclements. Fix a pin at the critical point  $s = -1$ , orthogonal to the plane. Attach a string with one end at the critical point and the other on the Nyquist plot. Let the end of the string attached to the Nyquist curve traverse the whole curve. There are no encirclements if the string does not wind up on the pin when the curve is encircled.

### Example 10.2 Third-order system

Consider a third-order transfer function

$$L(s) = \frac{1}{(s+a)^3}.$$

To compute the Nyquist plot we start by evaluating points on the imaginary axis  $s = i\omega$ , which yields

$$L(i\omega) = \frac{1}{(i\omega+a)^3} = \frac{(a-i\omega)^3}{(a^2+\omega^2)^3} = \frac{a^3-3a\omega^2}{(a^2+\omega^2)^3} + i \frac{\omega^3-3a^2\omega}{(a^2+\omega^2)^3}.$$

This is plotted in the complex plane in Figure 10.4, with the points corresponding to  $\omega > 0$  drawn as a solid line and  $\omega < 0$  as a dashed line. Notice that these curves are mirror images of each other.

To complete the Nyquist plot, we compute  $L(s)$  for  $s$  on the outer arc of the Nyquist D contour. This arc has the form  $s = Re^{i\theta}$  for  $R \rightarrow \infty$ . This gives

$$L(Re^{i\theta}) = \frac{1}{(Re^{i\theta}+a)^3} \rightarrow 0 \quad \text{as } R \rightarrow \infty.$$

Thus the outer arc of the  $D$  contour maps to the origin on the Nyquist plot.  $\nabla$

An alternative to computing the Nyquist plot explicitly is to determine the plot from the frequency response (Bode plot), which gives the Nyquist curve for  $s = i\omega$ ,

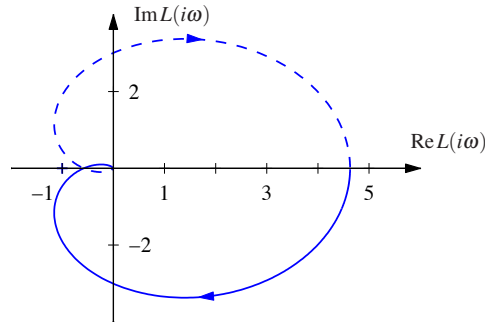

**Figure 10.4:** Nyquist plot for a third-order transfer function. The Nyquist plot consists of a trace of the loop transfer function  $L(s) = 1/(s+a)^3$  with  $a = 0.6$ . The solid line represents the portion of the transfer function along the positive imaginary axis, and the dashed line the negative imaginary axis. The outer arc of the D contour maps to the origin.

$\omega > 0$ . We start by plotting  $L(i\omega)$  from  $\omega = 0$  to  $\omega = \infty$ , which can be read off from the magnitude and phase of the transfer function. We then plot  $L(Re^{i\theta})$  with  $\theta \in [-\pi/2, \pi/2]$  and  $R \rightarrow \infty$ , which goes to zero if the high frequency gain of  $L(i\omega)$  goes to zero (iff  $L(s)$  is strictly proper). The remaining parts of the plot can be determined by taking the mirror image of the curve thus far (normally plotted using a dashed line). The plot can then be labeled with arrows corresponding to a clockwise traversal around the D contour (the same direction in which the first portion of the curve was plotted).

### Example 10.3 Third-order system with a pole at the origin

Consider the transfer function

$$L(s) = \frac{k}{s(s+1)^2},$$

where the gain has the nominal value  $k = 1$ . The Bode plot is shown in Figure 10.5a. The system has a single pole at  $s = 0$  and a double pole at  $s = -1$ . The gain curve of the Bode plot thus has the slope  $-1$  for low frequencies, and at the double pole  $s = 1$  the slope changes to  $-3$ . For small  $s$  we have  $L \approx k/s$ , which means that the low-frequency asymptote intersects the unit gain line at  $\omega = k$ . The phase curve starts at  $-90^\circ$  for low frequencies, it is  $-180^\circ$  at the breakpoint  $\omega = 1$  and it is  $-270^\circ$  at high frequencies.

Having obtained the Bode plot, we can now sketch the Nyquist plot, shown in Figure 10.5b. It starts with a phase of  $-90^\circ$  for low frequencies, intersects the negative real axis at the breakpoint  $\omega = 1$  where  $L(i) = -0.5$  and goes to zero along the imaginary axis for high frequencies. The small half-circle of the D contour at the origin is mapped on a large circle enclosing the right half-plane. The Nyquist curve does not encircle the critical point, and it follows from the simplified Nyquist theorem that the closed loop system is stable. Since  $L(i) = -k/2$ , we find the closed loop system becomes unstable if the gain is increased to  $k = 2$  or beyond.

▽

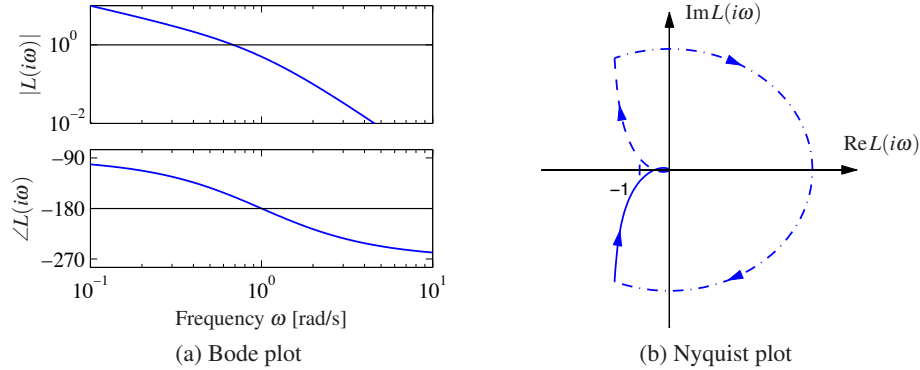

**Figure 10.5:** Sketching Nyquist and Bode plots. The loop transfer function is  $L(s) = 1/(s(s+1)^2)$ . The large semicircle is the map of the small semicircle of the  $D$  contour around the pole at the origin. The closed loop is stable because the Nyquist curve does not encircle the critical point. The point where the phase is  $-180^\circ$  is marked with a circle in the Bode plot.

The Nyquist criterion does not require that  $|L(i\omega_c)| < 1$  for all  $\omega_c$  corresponding to a crossing of the negative real axis. Rather, it says that the number of encirclements must be zero, allowing for the possibility that the Nyquist curve could cross the negative real axis and cross back at magnitudes greater than 1. The fact that it was possible to have high feedback gains surprised the early designers of feedback amplifiers, as mentioned in the quote in the beginning of this chapter.

One advantage of the Nyquist criterion is that it tells us how a system is influenced by changes of the controller parameters. For example, it is very easy to visualize what happens when the gain is changed since this just scales the Nyquist curve.

#### Example 10.4 Congestion control

Consider the Internet congestion control system described in Section 4.4. Suppose we have  $N$  identical sources and a disturbance  $d$  representing an external data source, as shown in Figure 10.6a. We let  $w$  represent the individual window size for a source,  $q$  represent the end-to-end probability of a dropped packet,  $b$  represent the number of packets in the router's buffer and  $p$  represent the probability that a packet is dropped by the router. We write  $\bar{w}$  for the total number of packets being received from all  $N$  sources. We also include a time delay between the router and the senders, representing the time delays between the sender and receiver.

To analyze the stability of the system, we use the transfer functions computed in Exercise 9.12:

$$\tilde{G}_{b\bar{w}}(s) = \frac{1}{\tau_e s + e^{-\tau_f s}}, \quad G_{wq}(s) = -\frac{1}{q_e(\tau_e s + q_e w_e)}, \quad G_{pb}(s) = \rho,$$

where  $(w_e, b_e)$  is the equilibrium point for the system,  $N$  is the number of sources,  $\tau_e$  is the steady-state round-trip time and  $\tau_f$  is the forward propagation time. We use  $\tilde{G}_{b\bar{w}}$  to represent the transfer function with the forward time delay removed

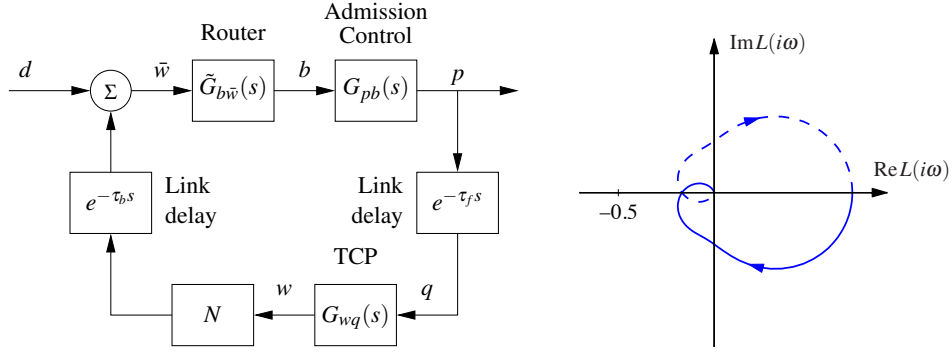

**Figure 10.6:** Internet congestion control. A set of  $N$  sources using TCP/Reno send messages through a single router with admission control (left). Link delays are included for the forward and backward directions. The Nyquist plot for the loop transfer function is shown on the right.

since this is accounted for as a separate block in Figure 10.6a. Similarly,  $G_{wq} = G_{\bar{w}q}/N$  since we have pulled out the multiplier  $N$  as a separate block as well.

The loop transfer function is given by

$$L(s) = \rho \cdot \frac{N}{\tau_e s + e^{-\tau_f s}} \cdot \frac{1}{q_e(\tau_e s + q_e w_e)} e^{-\tau_e s}.$$

Using the fact that  $q_e \approx 2N/w_e^2 = 2N^3/(\tau_e c)^2$  and  $w_e = b_e/N = \tau_e c/N$  from equation (4.22), we can show that

$$L(s) = \rho \cdot \frac{N}{\tau_e s + e^{-\tau_f s}} \cdot \frac{c^3 \tau_e^3}{2N^3(c\tau_e^2 s + 2N^2)} e^{-\tau_e s}.$$

Note that we have chosen the sign of  $L(s)$  to use the same sign convention as in Figure 10.1b. The exponential term representing the time delay gives significant phase above  $\omega = 1/\tau_e$ , and the gain at the crossover frequency will determine stability.

To check stability, we require that the gain be sufficiently small at crossover. If we assume that the pole due to the queue dynamics is sufficiently fast that the TCP dynamics are dominant, the gain at the crossover frequency  $\omega_c$  is given by

$$|L(i\omega_c)| = \rho \cdot N \cdot \frac{c^3 \tau_e^3}{2N^3 c \tau_e^2 \omega_c} = \frac{\rho c^2 \tau_e}{2N^2 \omega_c}.$$

Using the Nyquist criterion, the closed loop system will be unstable if this quantity is greater than 1. In particular, for a fixed time delay, the system will become unstable as the link capacity  $c$  is increased. This indicates that the TCP protocol may not be scalable to high-capacity networks, as pointed out by Low et al. [LPD02]. Exercise 10.7 provides some ideas of how this might be overcome.  $\nabla$

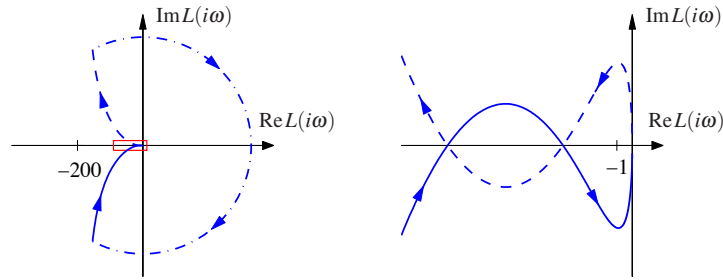

**Figure 10.7:** Nyquist curve for the loop transfer function  $L(s) = \frac{3(s+6)^2}{s(s+1)^2}$ . The plot on the right is an enlargement of the box around the origin of the plot on the left. The Nyquist curve intersects the negative real axis twice but has no net encirclements of  $-1$ .

### Conditional Stability

An unstable systems can often be stabilized simply by reducing the loop gain. There are, however, situations where a system can be stabilized by increasing the gain. This was first encountered by electrical engineers in the design of feedback amplifiers, who coined the term *conditional stability*. The problem was actually a strong motivation for Nyquist to develop his theory. We will illustrate this by an example.

#### Example 10.5 Third-order system

Consider a feedback system with the loop transfer function

$$L(s) = \frac{3(s+6)^2}{s(s+1)^2}. \quad (10.4)$$

The Nyquist plot of the loop transfer function is shown in Figure 10.7. Notice that the Nyquist curve intersects the negative real axis twice. The first intersection occurs at  $L = -12$  for  $\omega = 2$ , and the second at  $L = -4.5$  for  $\omega = 3$ . The intuitive argument based on signal tracing around the loop in Figure 10.1b is misleading in this case. Injection of a sinusoid with frequency 2 rad/s and amplitude 1 at A gives, in steady state, an oscillation at B that is in phase with the input and has amplitude 12. Intuitively it seems unlikely that closing of the loop will result in a stable system. However, it follows from Nyquist's stability criterion that the system is stable because there are no net encirclements of the critical point. Note, however, that if we *decrease* the gain, then we can get an encirclement, implying that the gain must be sufficiently large for stability.  $\nabla$

### General Nyquist Criterion

Theorem 10.1 requires that  $L(s)$  have no poles in the closed right half-plane. In some situations this is not the case and a more general result is required. Nyquist originally considered this general case, which we summarize as a theorem.

**Theorem 10.2** (Nyquist's stability theorem). *Consider a closed loop system with the loop transfer function  $L(s)$  that has  $P$  poles in the region enclosed by the*

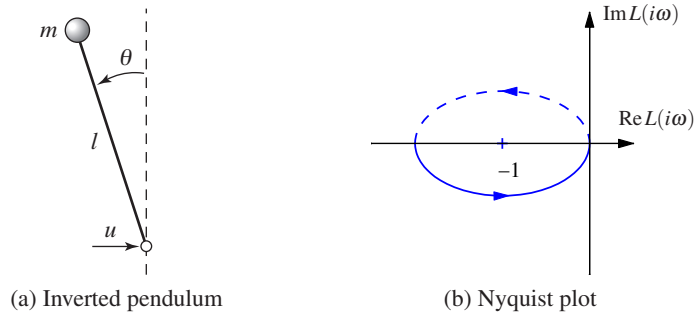

**Figure 10.8:** PD control of an inverted pendulum. (a) The system consists of a mass that is balanced by applying a force at the pivot point. A proportional-derivative controller with transfer function  $C(s) = k(s + 2)$  is used to command  $u$  based on  $\theta$ . (b) A Nyquist plot of the loop transfer function for gain  $k = 1$ . There is one counterclockwise encirclement of the critical point, giving  $N = -1$  clockwise encirclements.

*Nyquist contour.* Let  $N$  be the net number of clockwise encirclements of  $-1$  by  $L(s)$  when  $s$  encircles the Nyquist contour  $\Gamma$  in the clockwise direction. The closed loop system then has  $Z = N + P$  poles in the right half-plane.

The full Nyquist criterion states that if  $L(s)$  has  $P$  poles in the right half-plane, then the Nyquist curve for  $L(s)$  should have  $P$  counterclockwise encirclements of  $-1$  (so that  $N = -P$ ). In particular, this *requires* that  $|L(i\omega_c)| > 1$  for some  $\omega_c$  corresponding to a crossing of the negative real axis. Care has to be taken to get the right sign of the encirclements. The Nyquist contour has to be traversed clockwise, which means that  $\omega$  moves from  $-\infty$  to  $\infty$  and  $N$  is positive if the Nyquist curve winds clockwise. If the Nyquist curve winds counterclockwise, then  $N$  will be negative (the desired case if  $P \neq 0$ ).

As in the case of the simplified Nyquist criterion, we use small semicircles of radius  $r$  to avoid any poles on the imaginary axis. By letting  $r \rightarrow 0$ , we can use Theorem 10.2 to reason about stability. Note that the image of the small semicircles generates a section of the Nyquist curve with large magnitude, requiring care in computing the winding number.

### Example 10.6 Stabilized inverted pendulum

The linearized dynamics of a normalized inverted pendulum can be represented by the transfer function  $P(s) = 1/(s^2 - 1)$ , where the input is acceleration of the pivot and the output is the pendulum angle  $\theta$ , as shown in Figure 10.8 (Exercise 9.3). We attempt to stabilize the pendulum with a proportional-derivative (PD) controller having the transfer function  $C(s) = k(s + 2)$ . The loop transfer function is

$$L(s) = \frac{k(s + 2)}{s^2 - 1}.$$

The Nyquist plot of the loop transfer function is shown in Figure 10.8b. We have  $L(0) = -2k$  and  $L(\infty) = 0$ . If  $k > 0.5$ , the Nyquist curve encircles the critical point  $s = -1$  in the counterclockwise direction when the Nyquist contour  $\gamma$  is encircled



in the clockwise direction. The number of encirclements is thus  $N = -1$ . Since the loop transfer function has one pole in the right half-plane ( $P = 1$ ), we find that  $Z = N + P = 0$  and the system is thus stable for  $k > 0.5$ . If  $k < 0.5$ , there is no encirclement and the closed loop will have one pole in the right half-plane.  $\nabla$

### Derivation of Nyquist's Stability Theorem



We will now prove the Nyquist stability theorem for a general loop transfer function  $L(s)$ . This requires some results from the theory of complex variables, for which the reader can consult Ahlfors [Ahl66]. Since some precision is needed in stating Nyquist's criterion properly, we will use a more mathematical style of presentation. We also follow the mathematical convention of counting encirclements in the counterclockwise direction for the remainder of this section. The key result is the following theorem about functions of complex variables.

**Theorem 10.3** (Principle of variation of the argument). *Let  $D$  be a closed and bounded region in the complex plane and let  $\Gamma$  be the boundary of the region. Assume the function  $f : \mathbb{C} \rightarrow \mathbb{C}$  is analytic in  $D$  and on  $\Gamma$ , except at a finite number of poles and zeros. Then the winding number  $w_n$  is given by*

$$w_n = \frac{1}{2\pi} \Delta_{\Gamma} \arg f(z) = \frac{1}{2\pi i} \int_{\Gamma} \frac{f'(z)}{f(z)} dz = Z - P,$$

where  $\Delta_{\Gamma}$  is the net variation in the angle when  $z$  traverses the contour  $\Gamma$  in the counterclockwise direction,  $Z$  is the number of zeros in  $D$  and  $P$  is the number of poles in  $D$ . Poles and zeros of multiplicity  $m$  are counted  $m$  times.

*Proof.* Assume that  $z = a$  is a zero of multiplicity  $m$ . In the neighborhood of  $z = a$  we have

$$f(z) = (z - a)^m g(z),$$

where the function  $g$  is analytic and different from zero. The ratio of the derivative of  $f$  to itself is then given by

$$\frac{f'(z)}{f(z)} = \frac{m}{z - a} + \frac{g'(z)}{g(z)},$$

and the second term is analytic at  $z = a$ . The function  $f'/f$  thus has a single pole at  $z = a$  with the residue  $m$ . The sum of the residues at the zeros of the function is  $Z$ . Similarly, we find that the sum of the residues for the poles is  $-P$ , and hence

$$Z - P = \frac{1}{2\pi i} \int_{\Gamma} \frac{f'(z)}{f(z)} dz = \frac{1}{2\pi i} \int_{\Gamma} \frac{d}{dz} \log f(z) dz = \frac{1}{2\pi i} \Delta_{\Gamma} \log f(z),$$

where  $\Delta_{\Gamma}$  again denotes the variation along the contour  $\Gamma$ . We have

$$\log f(z) = \log |f(z)| + i \arg f(z),$$

and since the variation of  $|f(z)|$  around a closed contour is zero it follows that

$$\Delta_{\Gamma} \log f(z) = i \Delta_{\Gamma} \arg f(z),$$

and the theorem is proved.  $\square$

This theorem is useful in determining the number of poles and zeros of a function of complex variables in a given region. By choosing an appropriate closed region  $D$  with boundary  $\Gamma$ , we can determine the difference between the number of poles and zeros through computation of the winding number.

Theorem 10.3 can be used to prove Nyquist's stability theorem by choosing  $\Gamma$  as the Nyquist contour shown in Figure 10.3a, which encloses the right half-plane. To construct the contour, we start with part of the imaginary axis  $-jR \leq s \leq jR$  and a semicircle to the right with radius  $R$ . If the function  $f$  has poles on the imaginary axis, we introduce small semicircles with radii  $r$  to the right of the poles as shown in the figure. The Nyquist contour is obtained by selecting  $R$  large enough and  $r$  small enough so that all open-loop right half-plane poles are enclosed. Note that  $\Gamma$  has orientation *opposite* that shown in Figure 10.3a. (The convention in engineering is to traverse the Nyquist contour in the clockwise direction since this corresponds to moving upwards along the imaginary axis, which makes it easy to sketch the Nyquist contour from a Bode plot.)

To see how we use the principle of variation of the argument to compute stability, consider a closed loop system with the loop transfer function  $L(s)$ . The closed loop poles of the system are the zeros of the function  $f(s) = 1 + L(s)$ . To find the number of zeros in the right half-plane, we investigate the winding number of the function  $f(s) = 1 + L(s)$  as  $s$  moves along the Nyquist contour  $\Gamma$  in the *counterclockwise* direction. The winding number can conveniently be determined from the Nyquist plot. A direct application of Theorem 10.3 gives the Nyquist criterion, taking care to flip the orientation. Since the image of  $1 + L(s)$  is a shifted version of  $L(s)$ , we usually state the Nyquist criterion as net encirclements of the  $-1$  point by the image of  $L(s)$ .

### 10.3 Stability Margins

In practice it is not enough that a system is stable. There must also be some margins of stability that describe how far from instability the system is and its robustness to perturbations. There are many ways to express this, but one of the most common is the use of gain and phase margins, inspired by Nyquist's stability criterion. The key idea is that it is easy to plot the loop transfer function  $L(s)$ . An increase in controller gain simply expands the Nyquist plot radially. An increase in the phase of the controller twists the Nyquist plot. Hence from the Nyquist plot we can easily pick off the amount of gain or phase that can be added without causing the system to become unstable.

Formally, the *gain margin*  $g_m$  of a closed-loop system is defined as the smallest amount that the loop gain can be increased before the system goes unstable. For a system whose phase decreases monotonically as a function of frequency starting at  $0^\circ$ , the gain margin can be computed based on the smallest frequency where the phase of the loop transfer function  $L(s)$  is  $-180^\circ$ . Let  $\omega_{pc}$  represent this frequency,

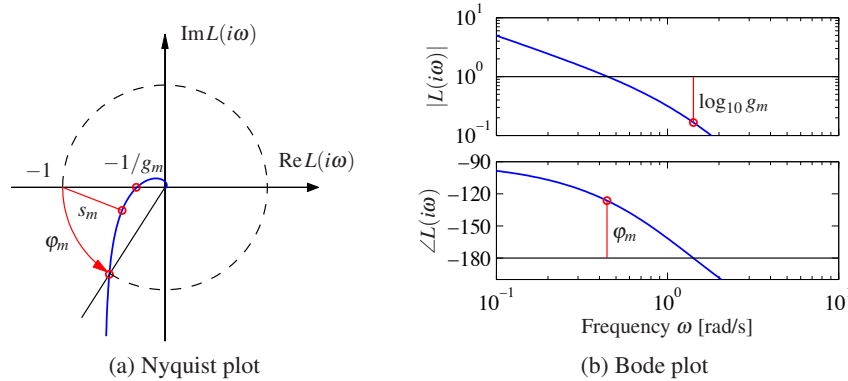

**Figure 10.9:** Stability margins. The gain margin  $g_m$  and phase margin  $\phi_m$  are shown on the Nyquist plot (a) and the Bode plot (b). The gain margin corresponds to the smallest increase in gain that creates an encirclement, and the phase margin is the smallest change in phase that creates an encirclement. The Nyquist plot also shows the stability margin  $s_m$ , which is the shortest distance to the critical point  $-1$ .

called the *phase crossover frequency*. Then the gain margin for the system is given by

$$g_m = \frac{1}{|L(i\omega_{pc})|}. \quad (10.5)$$

Similarly, the *phase margin* is the amount of phase lag required to reach the stability limit. Let  $\omega_{gc}$  be the *gain crossover frequency*, the smallest frequency where the loop transfer function  $L(s)$  has unit magnitude. Then for a system with monotonically decreasing gain, the phase margin is given by

$$\phi_m = \pi + \arg L(i\omega_{gc}). \quad (10.6)$$

These margins have simple geometric interpretations in the Nyquist plot, as shown in Figure 10.9a, where we have plotted the portion of the curve corresponding to  $\omega > 0$ . The gain margin is given by the inverse of the distance to the nearest point between  $-1$  and  $0$  where the loop transfer function crosses the negative real axis. The phase margin is given by the smallest angle on the unit circle between  $-1$  and the loop transfer function. When the gain or phase is monotonic, this geometric interpretation agrees with the formulas above.

A drawback with gain and phase margins is that both have to be given to guarantee that the Nyquist curve is not close to the critical point. An alternative way to express margins is by a single number, the *stability margin*  $s_m$ , which is the shortest distance from the Nyquist curve to the critical point. The gain and phase margins can also be determined from the Bode plot as indicated in Figure 10.9.

### Example 10.7 Third-order system

Consider a loop transfer function  $L(s) = 3/(s+1)^3$ . The Nyquist and Bode plots are shown in Figure 10.10. To compute the gain, phase and stability margins, we

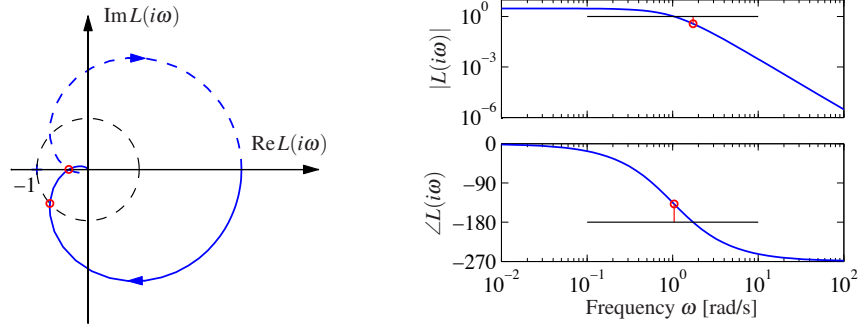

**Figure 10.10:** Stability margins for a third-order transfer function. The Nyquist plot on the left allows the gain, phase and stability margins to be determined by measuring the distances of relevant features. The gain and phase margins can also be read off of the Bode plot on the right.

can use the Nyquist plot shown in Figure 10.10. This yields the following values:

$$g_m = 2.67, \quad \phi_m = 41.7^\circ, \quad s_m = 0.464.$$

The gain and phase margins can also be determined from the Bode plot.  $\nabla$

The gain and phase margins are classical robustness measures that have been used for a long time in control system design. The gain margin is well defined if the Nyquist curve intersects the negative real axis once. Analogously, the phase margin is well defined if the Nyquist curve intersects the unit circle at only one point. Other more general robustness measures will be introduced in Chapter 13.

Even if both the gain and phase margins are reasonable, the system may still not be robust, as is illustrated by the following example.

### Example 10.8 Good gain and phase margins but poor stability margins

Consider a system with the loop transfer function

$$L(s) = \frac{0.38(s^2 + 0.1s + 0.55)}{s(s+1)(s^2 + 0.06s + 0.5)}.$$

A numerical calculation gives the gain margin as  $g_m = 266$ , and the phase margin is  $70^\circ$ . These values indicate that the system is robust, but the Nyquist curve is still close to the critical point, as shown in Figure 10.11. The stability margin is  $s_m = 0.27$ , which is very low. The closed loop system has two resonant modes, one with damping ratio  $\zeta = 0.81$  and the other with  $\zeta = 0.014$ . The step response of the system is highly oscillatory, as shown in Figure 10.11c.  $\nabla$

When designing feedback systems, it will often be useful to define the robustness of the system using gain, phase and stability margins. These numbers tell us how much the system can vary from our nominal model and still be stable. Reasonable values of the margins are phase margin  $\phi_m = 30^\circ$ – $60^\circ$ , gain margin  $g_m = 2$ – $5$  and stability margin  $s_m = 0.5$ – $0.8$ .

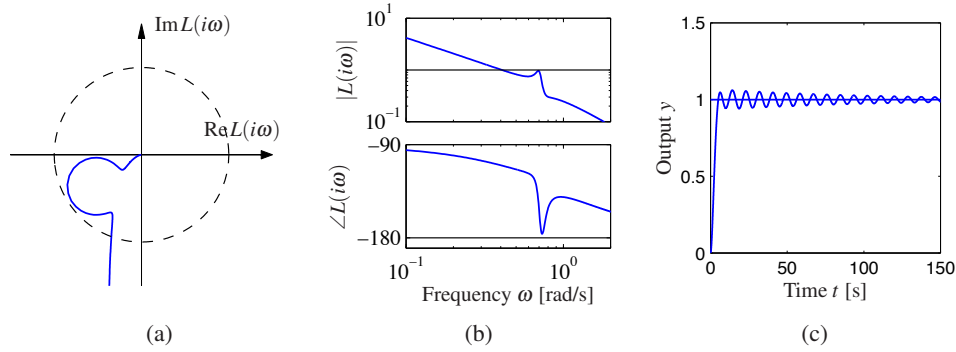

**Figure 10.11:** System with good gain and phase margins but a poor stability margin. Nyquist (a) and Bode (b) plots of the loop transfer function and step response (c) for a system with good gain and phase margins but with a poor stability margin. The Nyquist plot shows on the portion of the curve corresponding to  $\omega > 0$ .

There are also other stability measures, such as the *delay margin*, which is the smallest time delay required to make the system unstable. For loop transfer functions that decay quickly, the delay margin is closely related to the phase margin, but for systems where the gain curve of the loop transfer function has several peaks at high frequencies, the delay margin is a more relevant measure.

#### Example 10.9 Nanopositioning system for an atomic force microscope

Consider the system for horizontal positioning of the sample in an atomic force microscope. The system has oscillatory dynamics, and a simple model is a spring–mass system with low damping. The normalized transfer function is given by

$$P(s) = \frac{\omega_0^2}{s^2 + 2\zeta\omega_0s + \omega_0^2}, \quad (10.7)$$

where the damping ratio typically is a very small number, e.g.,  $\zeta = 0.1$ .

We will start with a controller that has only integral action. The resulting loop transfer function is

$$L(s) = \frac{k_i\omega_0^2}{s(s^2 + 2\zeta\omega_0s + \omega_0^2)},$$

where  $k_i$  is the gain of the controller. Nyquist and Bode plots of the loop transfer function are shown in Figure 10.12. Notice that the part of the Nyquist curve that is close to the critical point  $-1$  is approximately circular.

From the Bode plot in Figure 10.12b, we see that the phase crossover frequency is  $\omega_{pc} = \omega_0$ , which will be independent of the gain  $k_i$ . Evaluating the loop transfer function at this frequency, we have  $L(i\omega_0) = -k_i/(2\zeta\omega_0)$ , which means that the stability margin is  $s_m = 1 - k_i/(2\zeta\omega_0)$ . To have a desired stability margin of  $s_m$  the integral gain should be chosen as

$$k_i = 2\zeta\omega_0(1 - s_m).$$

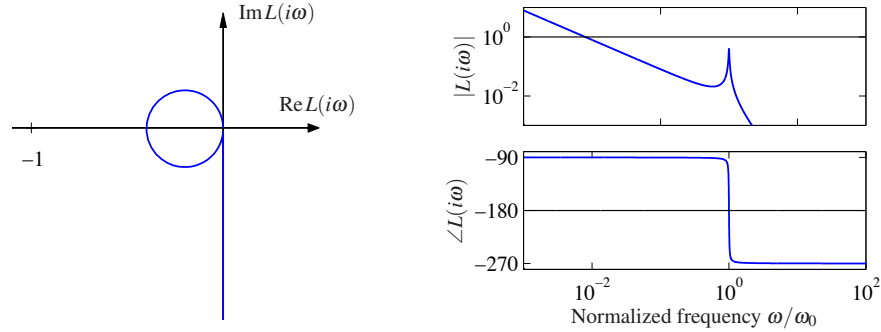

**Figure 10.12:** Nyquist and Bode plots of the loop transfer function for the AFM system (10.7) with an integral controller. The frequency in the Bode plot is normalized by  $\omega_0$ . The parameters are  $\zeta = 0.01$  and  $k_i = 0.008$ .

Figure 10.12 shows Nyquist and Bode plots for the system with gain margin  $g_m = 2.5$  and stability margin  $s_m = 0.6$ . The gain curve in the Bode plot is almost a straight line for low frequencies and has a resonant peak at  $\omega = \omega_0$ . The gain crossover frequency is approximately equal to  $k_i$  and the phase decreases monotonically from  $-90^\circ$  to  $-270^\circ$ : it is equal to  $-180^\circ$  at  $\omega = \omega_0$ . The curve can be shifted vertically by changing  $k_i$ : increasing  $k_i$  shifts the gain curve upward and increases the gain crossover frequency.  $\nabla$

#### 10.4 Bode's Relations and Minimum Phase Systems

An analysis of Bode plots reveals that there appears to be a relation between the gain curve and the phase curve. Consider, for example, the Bode plots for the differentiator and the integrator (shown in Figure 9.12). For the differentiator the slope is  $+1$  and the phase is a constant  $\pi/2$  radians. For the integrator the slope is  $-1$  and the phase is  $-\pi/2$ . For the first-order system  $G(s) = s + a$ , the amplitude curve has the slope 0 for small frequencies and the slope  $+1$  for high frequencies, and the phase is 0 for low frequencies and  $\pi/2$  for high frequencies.

Bode investigated the relations between the curves for systems with no poles and zeros in the right half-plane. He found that, for systems that do not have poles or zeros in the right half plane, the phase was uniquely given by the shape of the gain curve, and vice versa:

$$\arg G(i\omega_0) = \frac{\pi}{2} \int_0^\infty f(\omega) \frac{d \log |G(i\omega)|}{d \log \omega} d \log \omega \approx \frac{\pi}{2} \frac{d \log |G(i\omega_0)|}{d \log \omega_0}, \quad (10.8)$$

where  $f$  is the weighting kernel

$$f(\omega) = \frac{2}{\pi^2} \log \left| \frac{\omega + \omega_0}{\omega - \omega_0} \right|.$$

The phase curve is thus a weighted average of the derivative of the gain curve. If the gain curve has constant slope  $n$ , the phase curve has constant value  $n\pi/2$ .

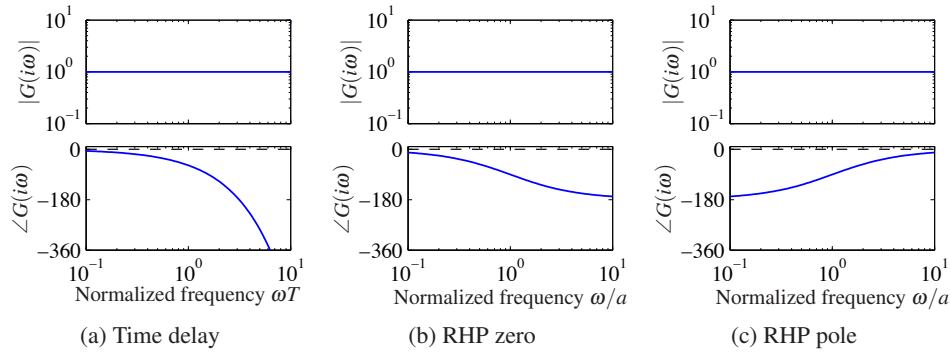

**Figure 10.13:** Bode plots of systems that are not minimum phase. (a) Time delay  $G(s) = e^{-sT}$ , (b) system with a right half-plane (RHP) zero  $G(s) = (a - s)/(a + s)$  and (c) system with right half-plane pole. The corresponding minimum phase system has the transfer function  $G(s) = 1$  in all cases, the phase curves for that system are shown as dashed lines.

Systems that do not have poles or zeros in the right half plane are called *minimum phase systems* because they have the smallest phase lag of all systems with the same gain curve. We will now give a few examples of nonminimum phase transfer functions.

The transfer function of a time delay of  $\tau$  units is  $G(s) = e^{-s\tau}$ . This transfer function has unit gain  $|G(i\omega)| = 1$ , and the phase is  $\arg G(i\omega) = -\omega\tau$ . The corresponding minimum phase system with unit gain has the transfer function  $G(s) = 1$ . The time delay thus has an additional phase lag of  $\omega\tau$ . Notice that the phase lag increases linearly with frequency. Figure 10.13a shows the Bode plot of the transfer function. (Because we use a log scale for frequency, the phase falls off exponentially in the plot.)

Consider a system with the transfer function  $G(s) = (a - s)/(a + s)$  with  $a > 0$ , which has a zero  $s = a$  in the right half-plane. The transfer function has unit gain  $|G(i\omega)| = 1$ , and the phase is  $\arg G(i\omega) = -2\arctan(\omega/a)$ . The corresponding minimum phase system with unit gain has the transfer function  $G(s) = 1$ . Figure 10.13b shows the Bode plot of the transfer function. A similar analysis of the transfer function  $G(s) = (s + a)/(s - a)$  with  $a > 0$ , which has a pole in the right half-plane, shows that its phase is  $\arg G(i\omega) = -2\arctan(a/\omega)$ . The Bode plot is shown in Figure 10.13c.

The presence of poles and zeros in the right half-plane imposes severe limitations on the achievable performance as will be discussed in Section 12.6. Dynamics of this type should be avoided by redesign of the system. While the poles are intrinsic properties of the system and they do not depend on sensors and actuators, the zeros depend on how inputs and outputs of a system are coupled to the states. Zeros can thus be changed by moving sensors and actuators or by introducing new sensors and actuators. Nonminimum phase systems are unfortunately quite common in practice.

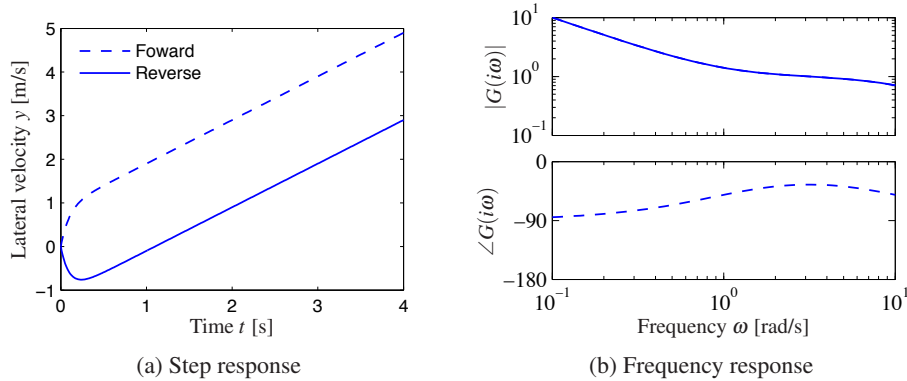

**Figure 10.14:** Vehicle steering for driving in reverse. (a) Step responses from steering angle to lateral translation for a simple kinematics model when driving forward (dashed) and reverse (solid). With rear-wheel steering the center of mass first moves in the wrong direction and that the overall response with rear-wheel steering is significantly delayed compared with that for front-wheel steering. (b) Frequency response for driving forward (dashed) and reverse (solid). Notice that the gain curves are identical, but the phase curve for driving in reverse has nonminimum phase.

The following example gives a system theoretic interpretation of the common experience that it is more difficult to drive in reverse gear and illustrates some of the properties of transfer functions in terms of their poles and zeros.

### Example 10.10 Vehicle steering

The unnormalized transfer function from steering angle to lateral velocity for the simple vehicle model is

$$G(s) = \frac{av_0s + v_0^2}{bs},$$

where  $v_0$  is the velocity of the vehicle and  $a, b > 0$  (see Example 6.12). The transfer function has a zero at  $s = v_0/a$ . In normal driving this zero is in the left half-plane, but it is in the right half-plane when driving in reverse,  $v_0 < 0$ . The unit step response is

$$y(t) = \frac{av_0}{b} + \frac{v_0^2 t}{b}.$$

The lateral velocity thus responds immediately to a steering command. For reverse steering  $v_0$  is negative and the initial response is in the wrong direction, a behavior that is representative for nonminimum phase systems (called an *inverse response*).

Figure 10.14 shows the step response for forward and reverse driving. In this simulation we have added an extra pole with the time constant  $T$  to approximately account for the dynamics in the steering system. The parameters are  $a = b = 1$ ,  $T = 0.1$ ,  $v_0 = 1$  for forward driving and  $v_0 = -1$  for reverse driving. Notice that for  $t > t_0 = a/v_0$ , where  $t_0$  is the time required to drive the distance  $a$ , the step response for reverse driving is that of forward driving with the time delay  $t_0$ . The position of the zero  $v_0/a$  depends on the location of the sensor. In our calculation



we have assumed that the sensor is at the center of mass. The zero in the transfer function disappears if the sensor is located at the rear wheel. The difficulty with zeros in the right half-plane can thus be visualized by a thought experiment where we drive a car in forward and reverse and observe the lateral position through a hole in the floor of the car.  $\nabla$

## 10.5 Generalized Notions of Gain and Phase



A key idea in frequency domain analysis is to trace the behavior of sinusoidal signals through a system. The concepts of gain and phase represented by the transfer function are strongly intuitive because they describe amplitude and phase relations between input and output. In this section we will see how to extend the concepts of gain and phase to more general systems, including some nonlinear systems. We will also show that there are analogs of Nyquist's stability criterion if signals are approximately sinusoidal.

### System Gain

We begin by considering the case of a static linear system  $y = Au$ , where  $A$  is a matrix whose elements are complex numbers. The matrix does not have to be square. Let the inputs and outputs be vectors whose elements are complex numbers and use the Euclidean norm

$$\|u\| = \sqrt{\sum |u_i|^2}. \quad (10.9)$$

The norm of the output is

$$\|y\|^2 = u^* A^* A u,$$

where  $*$  denotes the complex conjugate transpose. The matrix  $A^*A$  is symmetric and positive semidefinite, and the right-hand side is a quadratic form. The square root of eigenvalues of the matrix  $A^*A$  are all real, and we have

$$\|y\|^2 \leq \bar{\lambda}(A^*A) \|u\|^2,$$

where  $\bar{\lambda}$  denotes the largest eigenvalue. The gain of the system can then be defined as the maximum ratio of the output to the input over all possible inputs:

$$\gamma = \max_u \frac{\|y\|}{\|u\|} = \sqrt{\bar{\lambda}(A^*A)}. \quad (10.10)$$

The square root of the eigenvalues of the matrix  $A^*A$  are called the *singular values* of the matrix  $A$ , and the largest singular value is denoted by  $\bar{\sigma}(A)$ .

To generalize this to the case of an input/output dynamical system, we need to think of the inputs and outputs not as vectors of real numbers but as vectors of *signals*. For simplicity, consider first the case of scalar signals and let the signal space  $L_2$  be square-integrable functions with the norm

$$\|u\|_2 = \sqrt{\int_0^\infty |u|^2(\tau) d\tau}.$$

This definition can be generalized to vector signals by replacing the absolute value with the vector norm (10.9). We can now formally define the gain of a system taking inputs  $u \in L_2$  and producing outputs  $y \in L_2$  as

$$\gamma = \sup_{u \in L_2} \frac{\|y\|}{\|u\|}, \quad (10.11)$$

where sup is the *supremum*, defined as the smallest number that is larger or equal to its argument. The reason for using the supremum is that the maximum may not be defined for  $u \in L_2$ . This definition of the system gain is quite general and can even be used for some classes of nonlinear systems, though one needs to be careful about how initial conditions and global nonlinearities are handled.

The norm (10.11) has some nice properties in the case of linear systems. In particular, given a single-input, single-output stable linear system with transfer function  $G(s)$ , it can be shown that the norm of the system is given by

$$\gamma = \sup_{\omega} |G(i\omega)| =: \|G\|_{\infty}. \quad (10.12)$$

In other words, the gain of the system corresponds to the peak value of the frequency response. This corresponds to our intuition that an input produces the largest output when we are at the resonant frequencies of the system.  $\|G\|_{\infty}$  is called the *infinity norm* of the transfer function  $G(s)$ .

This notion of gain can be generalized to the multi-input, multi-output case as well. For a linear multivariable system with a transfer function matrix  $G(s)$  we can define the gain as

$$\gamma = \|G\|_{\infty} = \sup_{\omega} \bar{\sigma}(G(i\omega)). \quad (10.13)$$

Thus we can combine the idea of the gain of a matrix with the idea of the gain of a linear system by looking at the maximum singular value over all frequencies.

### Small Gain and Passivity

For linear systems it follows from Nyquist's theorem that the closed loop is stable if the gain of the loop transfer function is less than 1 for all frequencies. This result can be extended to a larger class of systems by using the concept of the system gain defined in equation (10.11).

**Theorem 10.4** (Small gain theorem). *Consider the closed loop system shown in Figure 10.15, where  $H_1$  and  $H_2$  are input/output stable systems and the signal spaces are properly defined. Let the gains of the systems  $H_1$  and  $H_2$  be  $\gamma_1$  and  $\gamma_2$ . Then the closed loop system is input/output stable if  $\gamma_1 \gamma_2 < 1$ , and the gain of the closed loop system is*

$$\gamma = \frac{\gamma_1}{1 - \gamma_1 \gamma_2}.$$

Notice that if systems  $H_1$  and  $H_2$  are linear, it follows from the Nyquist stability theorem that the closed loop is stable because if  $\gamma_1 \gamma_2 < 1$ , the Nyquist curve is

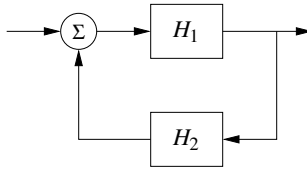

**Figure 10.15:** A feedback connection of two general nonlinear systems  $H_1$  and  $H_2$ . The stability of the system can be explored using the small gain theorem.

always inside the unit circle. The small gain theorem is thus an extension of the Nyquist stability theorem.

Although we have focused on linear systems, the small gain theorem also holds for nonlinear input/output systems. The definition of gain in equation (10.11) holds for nonlinear systems as well, with some care needed in handling the initial condition.

The main limitation of the small gain theorem is that it does not consider the phasing of signals around the loop, so it can be very conservative. To define the notion of phase we require that there be a scalar product. For square-integrable functions this can be defined as

$$\langle u, y \rangle = \int_0^{\infty} u(\tau)y(\tau) d\tau.$$

The phase  $\varphi$  between two signals can now be defined as

$$\langle u, y \rangle = \|u\| \|y\| \cos(\varphi).$$

Systems where the phase between inputs and outputs is  $90^\circ$  or less for all inputs are called *passive systems*. It follows from the Nyquist stability theorem that a closed loop linear system is stable if the phase of the loop transfer function is between  $-\pi$  and  $\pi$ . This result can be extended to nonlinear systems as well. It is called the *passivity theorem* and is closely related to the small gain theorem. See Khalil [Kha01] for a more detailed description.

Additional applications of the small gain theorem and its application to robust stability are given in Chapter 13.

### Describing Functions

For special nonlinear systems like the one shown in Figure 10.16a, which consists of a feedback connection between a linear system and a static nonlinearity, it is possible to obtain a generalization of Nyquist's stability criterion based on the idea of *describing functions*. Following the approach of the Nyquist stability condition, we will investigate the conditions for maintaining an oscillation in the system. If the linear subsystem has low-pass character, its output is approximately sinusoidal even if its input is highly irregular. The condition for oscillation can then be found by exploring the propagation of a sinusoid that corresponds to the first harmonic.

To carry out this analysis, we have to analyze how a sinusoidal signal propagates through a static nonlinear system. In particular we investigate how the first

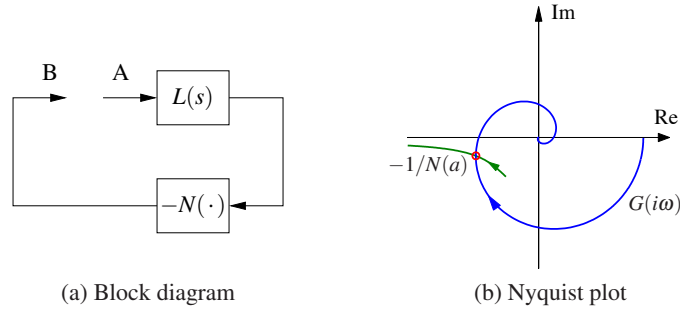

**Figure 10.16:** Describing function analysis. A feedback connection between a static nonlinearity and a linear system is shown in (a). The linear system is characterized by its transfer function  $L(s)$ , which depends on frequency, and the nonlinearity by its describing function  $N(a)$ , which depends on the amplitude  $a$  of its input. The Nyquist plot of  $L(i\omega)$  and the plot of the  $-1/N(a)$  are shown in (b). The intersection of the curves represents a possible limit cycle.

harmonic of the output of the nonlinearity is related to its (sinusoidal) input. Letting  $F$  represent the nonlinear function, we expand  $F(e^{i\omega t})$  in terms of its harmonics:

$$F(ae^{i\omega t}) = \sum_{n=0}^{\infty} M_n(a)e^{i(n\omega t + \varphi_n(a))},$$

where  $M_n(a)$  and  $\varphi_n(a)$  represent the gain and phase of the  $n$ th harmonic, which depend on the input amplitude since the function  $F$  is nonlinear. We define the describing function to be the complex gain of the first harmonic:

$$N(a) = M_1(a)e^{i\varphi_1(a)}. \quad (10.14)$$

The function can also be computed by assuming that the input is a sinusoid and using the first term in the Fourier series of the resulting output.

Neglecting higher harmonics and arguing as we did when deriving Nyquist's stability criterion, we find that an oscillation can be maintained if

$$L(i\omega)N(a) = -1. \quad (10.15)$$

This equation means that if we inject a sinusoid of amplitude  $a$  at A in Figure 10.16, the same signal will appear at B and an oscillation can be maintained by connecting the points. Equation (10.15) gives two conditions for finding the frequency  $\omega$  of the oscillation and its amplitude  $a$ : the phase must be  $180^\circ$ , and the magnitude must be unity. A convenient way to solve the equation is to plot  $L(i\omega)$  and  $-1/N(a)$  on the same diagram as shown in Figure 10.16b. The diagram is similar to the Nyquist plot where the critical point  $-1$  is replaced by the curve  $-1/N(a)$  and  $a$  ranges from 0 to  $\infty$ .

It is possible to define describing functions for types of inputs other than sinusoids. Describing function analysis is a simple method, but it is approximate because it assumes that higher harmonics can be neglected. Excellent treatments

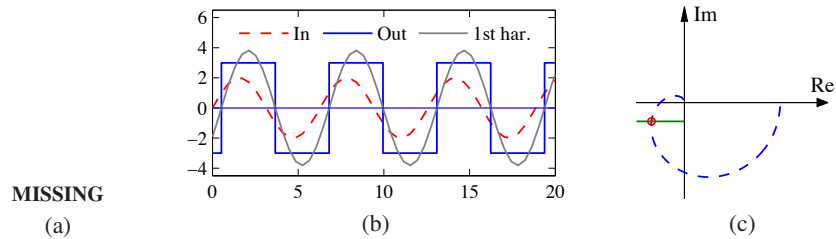

**Figure 10.17:** Describing function analysis for a relay with hysteresis. The input/output relation of the hysteresis is shown in (a) and the input with amplitude  $a = 2$ , the output and its first harmonic are shown in (b). The Nyquist plots of the transfer function  $L(s) = (s + 1)^{-4}$  and the negative of the inverse describing function for the relay with  $b = 3$  and  $c = 1$  are shown in (c).

of describing function techniques can be found in the texts by Atherton [Ath75] and Graham and McRuer [GM61].

#### Example 10.11 Relay with hysteresis

Consider a linear system with a nonlinearity consisting of a relay with hysteresis. The output has amplitude  $b$  and the relay switches when the input is  $\pm c$ , as shown in Figure 10.17a. Assuming that the input is  $u = a \sin(\omega t)$ , we find that the output is zero if  $a \leq c$ , and if  $a > c$ , the output is a square wave with amplitude  $b$  that switches at times  $\omega t = \arcsin(c/a) + n\pi$ . The first harmonic is then  $y(t) = (4b/\pi) \sin(\omega t - \alpha)$ , where  $\sin \alpha = c/a$ . For  $a > c$  the describing function and its inverse are

$$N(a) = \frac{4b}{a\pi} \left( \sqrt{1 - \frac{c^2}{a^2}} - i \frac{c}{a} \right), \quad \frac{1}{N(a)} = \frac{\pi \sqrt{a^2 - c^2}}{4b} + i \frac{\pi c}{4b},$$

where the inverse is obtained after simple calculations. Figure 10.17b shows the response of the relay to a sinusoidal input with the first harmonic of the output shown as a dashed line. Describing function analysis is illustrated in Figure 10.17c, which shows the Nyquist plot of the transfer function  $L(s) = 2/(s + 1)^4$  (dashed line) and the negative inverse describing function of a relay with  $b = 1$  and  $c = 0.5$ . The curves intersect for  $a = 1$  and  $\omega = 0.77$  rad/s, indicating the amplitude and frequency for a possible oscillation if the process and the relay are connected in a feedback loop.  $\nabla$

## 10.6 Further Reading

Nyquist's original paper giving his now famous stability criterion was published in the *Bell Systems Technical Journal* in 1932 [Nyq32]. More accessible versions are found in the book [BK64], which also includes other interesting early papers on control. Nyquist's paper is also reprinted in an IEEE collection of seminal papers on control [Bas01]. Nyquist used  $+1$  as the critical point, but Bode changed it to

$-1$ , which is now the standard notation. Interesting perspectives on early developments are given by Black [Bla77], Bode [Bod60] and Bennett [Ben93]. Nyquist did a direct calculation based on his insight into the propagation of sinusoidal signals through systems; he did not use results from the theory of complex functions. The idea that a short proof can be given by using the principle of variation of the argument is presented in the delightful book by MacColl [Mac45]. Bode made extensive use of complex function theory in his book [Bod45], which laid the foundation for frequency response analysis where the notion of minimum phase was treated in detail. A good source for complex function theory is the classic by Ahlfors [Ahl66]. Frequency response analysis was a key element in the emergence of control theory as described in the early texts by James et al. [JNP47], Brown and Campbell [BC48] and Oldenburger [Old56], and it became one of the cornerstones of early control theory. Frequency response methods underwent a resurgence when robust control emerged in the 1980s, as will be discussed in Chapter 13.

## Exercises

**10.1** (Operational amplifier) Consider an op amp circuit with  $Z_1 = Z_2$  that gives a closed loop system with nominally unit gain. Let the transfer function of the operational amplifier be

$$G(s) = \frac{ka_1a_2}{(s+a)(s+a_1)(s+a_2)},$$

where  $a_1, a_2 \gg a$ . Show that the condition for oscillation is  $k < a_1 + a_2$  and compute the gain margin of the system. Hint: Assume  $a = 0$ .

**10.2** (Atomic force microscope) The dynamics of the tapping mode of an atomic force microscope are dominated by the damping of the cantilever vibrations and the system that averages the vibrations. Modeling the cantilever as a spring–mass system with low damping, we find that the amplitude of the vibrations decays as  $\exp(-\zeta\omega t)$ , where  $\zeta$  is the damping ratio and  $\omega$  is the undamped natural frequency of the cantilever. The cantilever dynamics can thus be modeled by the transfer function

$$G(s) = \frac{a}{s+a},$$

where  $a = \zeta\omega_0$ . The averaging process can be modeled by the input/output relation

$$y(t) = \frac{1}{\tau} \int_{t-\tau}^t u(v)dv,$$

where the averaging time is a multiple  $n$  of the period of the oscillation  $2\pi/\omega$ . The dynamics of the piezo scanner can be neglected in the first approximation because they are typically much faster than  $a$ . A simple model for the complete system is thus given by the transfer function

$$P(s) = \frac{a(1 - e^{-s\tau})}{s\tau(s+a)}.$$

Plot the Nyquist curve of the system and determine the gain of a proportional controller that brings the system to the boundary of stability.

**10.3** (Heat conduction) A simple model for heat conduction in a solid is given by the transfer function

$$P(s) = ke^{-\sqrt{s}}.$$

Sketch the Nyquist plot of the system. Determine the frequency where the phase of the process is  $-180^\circ$  and the gain at that frequency. Show that the gain required to bring the system to the stability boundary is  $k = e^\pi$ .

**10.4** (Vectored thrust aircraft) Consider the state space controller designed for the vectored thrust aircraft in Examples 7.8 and 8.5. The controller consists of two components: an optimal estimator to compute the state of the system from the output and a state feedback compensator that computes the input given the (estimated) state. Compute the loop transfer function for the system and determine the gain, phase and stability margins for the closed loop dynamics. 

**10.5** (Vehicle steering) Consider the linearized model for vehicle steering with a controller based on state feedback discussed in Example 8.4. The transfer functions for the process and controller are given by

$$P(s) = \frac{\gamma s + 1}{s^2}, \quad C(s) = \frac{s(k_1 l_1 + k_2 l_2) + k_1 l_2}{s^2 + s(\gamma k_1 + k_2 + l_1) + k_1 + l_2 + k_2 l_1 - \gamma k_2 l_2},$$

as computed in Example 9.10. Let the process parameter be  $\gamma = 0.5$  and assume that the state feedback gains are  $k_1 = 1$  and  $k_2 = 0.914$  and that the observer gains are  $l_1 = 2.828$  and  $l_2 = 4$ . Compute the stability margins numerically.

**10.6** (Stability margins for second-order systems) A process whose dynamics is described by a double integrator is controlled by an ideal PD controller with the transfer function  $C(s) = k_d s + k_p$ , where the gains are  $k_d = 2\zeta\omega_0$  and  $k_p = \omega_0^2$ . Calculate and plot the gain, phase and stability margins as a function  $\zeta$ .

**10.7** (Congestion control in overload conditions) A strongly simplified flow model of a TCP loop under overload conditions is given by the loop transfer function

$$L(s) = \frac{k}{s} e^{-s\tau},$$

where the queuing dynamics are modeled by an integrator, the TCP window control is a time delay  $\tau$  and the controller is simply a proportional controller. A major difficulty is that the time delay may change significantly during the operation of the system. Show that if we can measure the time delay, it is possible to choose a gain that gives a stability margin of  $s_m \geq 0.6$  for all time delays  $\tau$ .

**10.8** (Bode's formula) Consider Bode's formula (10.8) for the relation between gain and phase for a transfer function that has all its singularities in the left half-plane. Plot the weighting function and make an assessment of the frequencies where the approximation  $\arg G \approx (\pi/2)d \log |G|/d \log \omega$  is valid.

**10.9** (Padé approximation to a time delay) Consider the transfer functions

$$G_1(s) = e^{-s\tau}, \quad G_2(s) = e^{-s\tau} \approx \frac{1 - s\tau/2}{1 + s\tau/2}. \quad (10.16)$$

Show that the minimum phase properties of the transfer functions are similar for frequencies  $\omega < 1/\tau$ . A long time delay  $\tau$  is thus equivalent to a small right half-plane zero. The approximation (10.16) is called a first-order *Padé approximation*.

**10.10** (Inverse response) Consider a system whose input/output response is modeled by  $G(s) = 6(-s + 1)/(s^2 + 5s + 6)$ , which has a zero in the right half-plane. Compute the step response for the system, and show that the output goes in the wrong direction initially, which is also referred to as an *inverse response*. Compare the response to a minimum phase system by replacing the zero at  $s = 1$  with a zero at  $s = -1$ .

**10.11** (Describing function analysis) Consider the system with the block diagram shown on the left below.

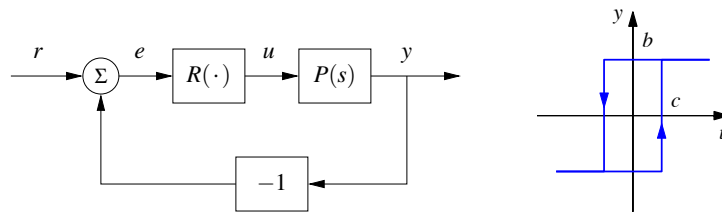

The block  $R$  is a relay with hysteresis whose input/output response is shown on the right and the process transfer function is  $P(s) = e^{-s\tau}/s$ . Use describing function analysis to determine frequency and amplitude of possible limit cycles. Simulate the system and compare with the results of the describing function analysis.



---

# Chapter Eleven

## PID Control

*Based on a survey of over eleven thousand controllers in the refining, chemicals and pulp and paper industries, 97% of regulatory controllers utilize PID feedback.*

L. Desborough and R. Miller, 2002 [DM02].

This chapter treats the basic properties of proportional-integral-derivative (PID) control and the methods for choosing the parameters of the controllers. We also analyze the effects of actuator saturation and time delay, two important features of many feedback systems, and describe methods for compensating for these effects. Finally, we will discuss the implementation of PID controllers as an example of how to implement feedback control systems using analog or digital computation.

### 11.1 Basic Control Functions

PID control, which was introduced in Section 1.5 and has been used in several examples, is by far the most common way of using feedback in engineering systems. It appears in simple devices and in large factories with thousands of controllers. PID controllers appear in many different forms: as stand-alone controllers, as part of hierarchical, distributed control systems and built into embedded components. Most PID controllers do not use derivative action, so they should strictly speaking be called PI controllers; we will, however, use PID as a generic term for this class of controller. There is also growing evidence that PID control appears in biological systems [YHSD00].

Block diagrams of closed loop systems with PID controllers are shown in Figure 11.1. The control signal  $u$  for the system in Figure 11.1a is formed entirely from the error  $e$ ; there is no feedforward term (which would correspond to  $k_r r$  in the state feedback case). A common alternative in which proportional and derivative action do not act on the reference is shown in Figure 11.1b; combinations of the schemes will be discussed in Section 11.5. The command signal  $r$  is called the reference signal in regulation problems, or the *setpoint* in the literature of PID control. The input/output relation for an ideal PID controller with error feedback is

$$u = k_p e + k_i \int_0^t e(\tau) d\tau + k_d \frac{de}{dt} = k_p \left( e + \frac{1}{T_i} \int_0^t e(\tau) d\tau + T_d \frac{de}{dt} \right). \quad (11.1)$$

The control action is thus the sum of three terms: proportional feedback, the integral term and derivative action. For this reason PID controllers were originally called *three-term controllers*. The controller parameters are the proportional gain

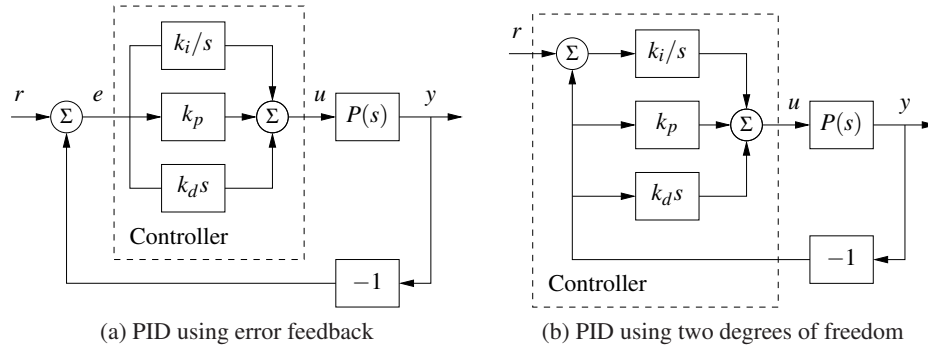

**Figure 11.1:** Block diagrams of closed loop systems with ideal PID controllers. Both controllers have one output, the control signal  $u$ . The controller in (a), which is based on error feedback, has one input, the control error  $e = r - y$ . For this controller proportional, integral and derivative action acts on the error  $e = r - y$ . The two degree-of-freedom controller in (b) has two inputs, the reference  $r$  and the process output  $y$ . Integral action acts on the error, but proportional and derivative action act on the process output  $y$ .

$k_p$ , the integral gain  $k_i$  and the derivative gain  $k_d$ . The controller can also be parameterized with the time constants  $T_i = k_p/k_i$  and  $T_d = k_d/k_p$ , called integral time (constant) and derivative time (constant).

The controller (11.1) represents an idealized controller. It is a useful abstraction for understanding the PID controller, but several modifications must be made to obtain a controller that is practically useful. Before discussing these practical issues we will develop some intuition about PID control.

We start by considering pure proportional feedback. Figure 11.2a shows the responses of the process output to a unit step in the reference value for a system with pure proportional control at different gain settings. In the absence of a feedforward term, the output never reaches the reference, and hence we are left with nonzero steady-state error. Letting the process transfer function be  $P(s)$ , with proportional feedback we have  $C(s) = k_p$  and the transfer function from reference to error is

$$G_{er}(s) = \frac{1}{1 + k_p P(s)}. \quad (11.2)$$

Assuming that the closed loop is stable the steady-state error for a unit step is

$$G_{er}(0) = \frac{1}{1 + k_p P(0)}.$$

For the system in Figure 11.2a with gains  $k_p = 1, 2$  and  $5$ , the steady-state error is  $0.5, 0.33$  and  $0.17$ . The error decreases with increasing gain, but the system also becomes more oscillatory. The system becomes unstable for  $k_p = 8$ . Notice in the figure that the initial value of the control signal equals the controller gain.

To avoid having a steady-state error, the proportional term can be changed to

$$u(t) = k_p e(t) + u_{\text{ff}}, \quad (11.3)$$

where  $u_{\text{ff}}$  is a feedforward term that is adjusted to give the desired steady-state

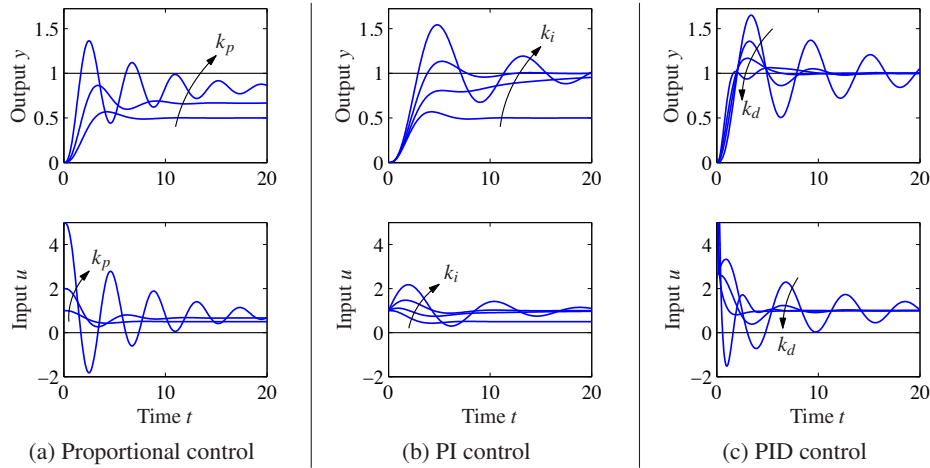

**Figure 11.2:** Responses to step changes in the reference value for a system with a proportional controller (a), PI controller (b) and PID controller (c). The process has the transfer function  $P(s) = 1/(s+1)^3$ , the proportional controller has parameters  $k_p = 1, 2$  and  $5$ , the PI controller has parameters  $k_p = 1, k_i = 0, 0.2, 0.5$  and  $1$ , and the PID controller has parameters  $k_p = 2.5, k_i = 1.5$  and  $k_d = 0, 1, 2$  and  $4$ .

value. If  $r$  is constant and we choose  $u_{\text{ff}} = r/P(0) = k_r r$ , then the steady-state output will be exactly equal to the reference value, as it was in the state space case, provided that there are no disturbances. However, this requires exact knowledge of the process dynamics, which is usually not available. The parameter  $u_{\text{ff}}$ , called *reset* in the PID literature, must therefore be adjusted manually.

Another alternative to avoid a steady state error is to multiply the reference by  $1 + k_p P(0)$ , but this also requires precise knowledge of the steady state gain of the process.

As we saw in Section 7.4, integral action guarantees that the process output agrees with the reference in steady-state and provides an alternative to the feed-forward term. Since this result is so important, we will provide a general proof. Consider the controller given by equation (11.1) with  $k_i \neq 0$ . Assume that  $u(t)$  and  $e(t)$  converge to steady-state values  $u = u_0$  and  $e = e_0$ . It then follows from equation (11.1) that

$$u_0 = k_p e_0 + k_i \lim_{t \rightarrow \infty} \int_0^t e(t) dt$$

The limit of the right hand side is not finite unless  $e(t)$  goes to zero which implies that  $e_0 = 0$ . We can thus conclude that with integral action the error will be zero if it reaches a steady state. Notice that we have not assumed that the process is linear or time invariant. We have, however, assumed that an equilibrium reached. Analysis based on transfer functions require that the closed loop system is linear and time invariant.

Using integral action to achieve zero steady-state error is much better than using feedforward, which requires a precise knowledge of process parameters.

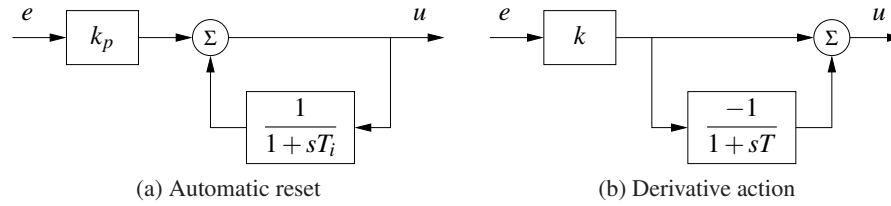

**Figure 11.3:** The block diagram in (a) shows how integral action is implemented using *positive feedback* with a first-order system, sometimes called *automatic reset*. The block diagram in (b) shows how derivative action can be implemented by taking differences between a static system and a first-order system.

The effect of integral action can also be understood from frequency domain analysis. The transfer function of the PID controller is

$$C(s) = k_p + \frac{k_i}{s} + k_d s. \quad (11.4)$$

The controller has infinite gain at zero frequency ( $C(0) = \infty$ ), and it then follows from equation (??) that  $G_{yr}(0) = 1$ , which implies that there is no steady-state error for a step input.

Integral action can also be viewed as a method for generating the feedforward term  $u_{ff}$  in the proportional controller (11.3) automatically. This is shown in Figure 11.3a, where the controller output is low-pass-filtered and fed back with positive gain. This implementation, called *automatic reset*, was one of the early inventions of integral control. The transfer function of the system in Figure 11.3a is obtained by block diagram algebra; we have

$$G_{ue} = k_p \frac{1+sT_i}{sT_i} = k_p + \frac{k_p}{sT_i},$$

which is the transfer function for a PI controller.

The properties of integral action are illustrated in Figure 11.2b for a step input. The proportional gain is constant,  $k_p = 1$ , and the integral gains are  $k_i = 0, 0.2, 0.5$  and  $1$ . The case  $k_i = 0$  corresponds to pure proportional control, with a steady-state error of 50%. The steady-state error is eliminated when integral gain action is used. The response creeps slowly toward the reference for small values of  $k_i$  and goes faster for larger integral gains, but the system also becomes more oscillatory.

The integral gain  $k_i$  is a useful measure for attenuation of load disturbances. Consider a closed loop system under PID control, like the one in Figure 9.1. Assume that the system is stable and initially at rest with all signals being zero. Apply a unit step load disturbance at the process input. After a transient the process output goes to zero and the controller output settles at a value that compensates for the disturbance. Since  $e(t)$  goes to zero as  $t \rightarrow \infty$  it follows from (11.1) that

$$u(\infty) = k_i \int_0^{\infty} e(t) dt.$$

The integrated error  $\int_0^{\infty} e(t) dt$  is thus inversely proportional to the integral gain

$k_i$ . The integral gain is thus a measure of the effectiveness of disturbance attenuation. A large gain  $k_i$  attenuates disturbances effectively, but too large a gain gives oscillatory behavior, poor robustness and possibly instability.

We now return to the general PID controller and consider the effect of the derivative term  $k_d$ . Recall that the original motivation for derivative feedback was to provide predictive or anticipatory action. Notice that the combination of the proportional and the derivative terms can be written as

$$u = k_p e + k_d \frac{de}{dt} = k_p \left( e + T_d \frac{de}{dt} \right) = k_p e_p,$$

where  $e_p(t)$  can be interpreted as a prediction of the error at time  $t + T_d$  by linear extrapolation. The prediction time  $T_d = k_d/k_p$  is the *derivative time constant* of the controller.

Derivative action can be implemented by taking the difference between the signal and its low-pass filtered version as shown in Figure 11.3b. The transfer function for the system is

$$G_{ue}(s) = k \left( 1 - \frac{1}{1+sT} \right) = k \frac{sT}{1+sT} = \frac{kTs}{1+sT}. \quad (11.5)$$

The transfer function  $G_{ue}(s)$ , approximates a derivative for low frequencies, because for  $|s| \ll 1/T$  we have  $G(s) \approx kTs$ . The transfer function  $G_{ue}$  acts like a differentiator for signals with frequencies low frequencies and as a constant gain  $k$  for high frequency signals.

Figure 11.2c illustrates the effect of derivative action: the system is oscillatory when no derivative action is used, and it becomes more damped as the derivative gain is increased. Performance deteriorates if the derivative gain is too high. When the input is a step, the controller output generated by the derivative term will be an impulse. This is clearly visible in Figure 11.2c. The impulse can be avoided by using the controller configuration shown in Figure 11.1b.

Although PID control was developed in the context of engineering applications, it also appears in nature. Disturbance attenuation by feedback in biological systems is often called *adaptation*. A typical example is the pupillary reflex discussed in Example 9.14, where it is said that the eye adapts to changing light intensity. Analogously, feedback with integral action is called perfect adaptation [YHSD00]. In biological systems proportional, integral and derivative action is generated by combining subsystems with dynamical behavior similarly to what is done in engineering systems. For example, PI action can be generated by the interaction of several hormones [ESGK02].

### Example 11.1 PD action in the retina

The response of cone photoreceptors in the retina is an example where proportional and derivative action is generated by a combination of cones and horizontal cells. The cones are the primary receptors stimulated by light, which in turn stimulate the horizontal cells, and the horizontal cells give inhibitory (negative) feedback to the cones. A schematic diagram of the system is shown in Figure 11.4a. The system

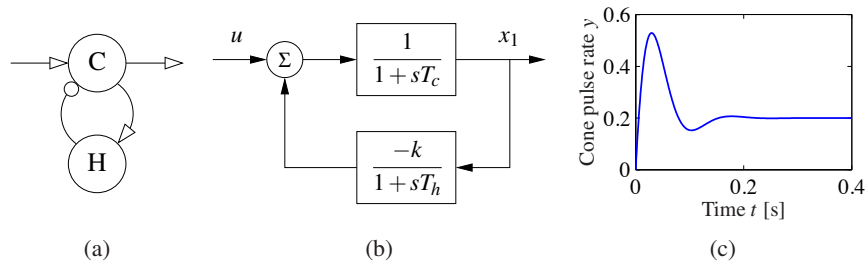

**Figure 11.4:** Schematic diagram of cone photoreceptors (C) and horizontal cells (H) in the retina. In the schematic diagram in (a), excitatory feedback is indicated by arrows and inhibitory feedback by circles. A block diagram is shown in (b) and the step response in (c).

can be modeled by ordinary differential equations by representing neuron signals as continuous variables representing the average pulse rate. In [Wil99] it is shown that the system can be represented by the differential equations

$$\frac{dx_1}{dt} = \frac{1}{T_c}(-x_1 - kx_2 + u), \quad \frac{dx_2}{dt} = \frac{1}{T_h}(x_1 - x_2),$$

where  $u$  is the light intensity and  $x_1$  and  $x_2$  are the average pulse rates from the cones and the horizontal cells. A block diagram of the system is shown in Figure 11.4b. The step response of the system shown in Figure 11.4c shows that the system has a large initial response followed by a lower, constant steady-state response typical of proportional and derivative action. The parameters used in the simulation are  $k = 4$ ,  $T_c = 0.025$  and  $T_h = 0.08$ . ▽

## 11.2 Simple Controllers for Complex Systems

Many of the design methods discussed in previous chapters have the property that the complexity of the controller is a direct reflection of the complexity of the model. When designing controllers by output feedback in Chapter 8, we found for single-input, single-output systems that the order of the controller was the same as the order of the model, possibly one order higher if integral action was required. Applying these design methods to PID control will require that the models have to be of first or second order; see Exercise ??.

Low-order models can be obtained from first principles. Any stable system can be modeled by a static system if its inputs are sufficiently slow. Similarly a first-order model is sufficient if the storage of mass, momentum or energy can be captured by only one variable; typical examples are the velocity of a car on a road, angular velocity of a stiff rotational system, the level in a tank and the concentration in a volume with good mixing. System dynamics are of second order if the storage of mass, energy and momentum can be captured by two state variables; typical examples are the position of a car on the road (position and velocity), the stabilization of stiff satellites (angular orientation and angular velocity), the levels in two connected tanks and two-compartment models. A wide range of techniques

for model reduction are also available. In this chapter we will focus on design techniques where we simplify the models to capture the essential properties that are needed for PID design.

We begin by analyzing the case of integral control. A stable system can be controlled by an integral controller provided that the requirements on the closed loop system are modest. To design the controller we assume that the transfer function of the process is a constant  $K = P(0)$ . The loop transfer function under integral control then becomes  $Kk_i/s$ , and the closed loop characteristic polynomial is simply  $s + Kk_i$ . Specifying performance by the desired time constant  $T_{cl}$  of the closed loop system, we find that the integral gain is given by

$$k_i = \frac{1}{T_{cl}P(0)}.$$

The analysis requires that  $T_{cl}$  be sufficiently large that the process transfer function can be approximated by a constant.

For systems that are not well represented by a constant gain, we can obtain a better approximation by using the Taylor series expansion of the loop transfer function:

$$L(s) = \frac{k_i P(s)}{s} \approx \frac{k_i(P(0) + sP'(0))}{s} = k_i P'(0) + \frac{k_i P(0)}{s}.$$

Choosing  $k_i P'(0) = -0.5$  gives a system with good robustness, as will be discussed in Section 13.5. The controller gain is then given by

$$k_i = -\frac{1}{2P'(0)}, \quad (11.6)$$

and the expected closed loop time constant is  $T_{cl} \approx -P'(0)/P(0)$ .

### Example 11.2 Integral control of AFM in tapping mode

A simplified model of the dynamics of the vertical motion of an atomic force microscope in tapping mode was discussed in Exercise 10.2. The transfer function for the system dynamics is

$$P(s) = \frac{a(1 - e^{-s\tau})}{s\tau(s + a)},$$

where  $a = \zeta\omega_0$ ,  $\tau = 2\pi n/\omega_0$  and the gain has been normalized to 1. We have  $P(0) = 1$  and  $P'(0) = -\tau/2 - 1/a$ , and it follows from (11.6) that the integral gain can be chosen as  $k_i = a/(2 + a\tau)$ . Nyquist and Bode plots for the resulting loop transfer function are shown in Figure 11.5.  $\nabla$

A first-order system has the transfer function

$$P(s) = \frac{b}{s + a}.$$

With a PI controller the closed loop system has the characteristic polynomial

$$s(s + a) + bk_p s + bk_i = s^2 + (a + bk_p)s + bk_i.$$

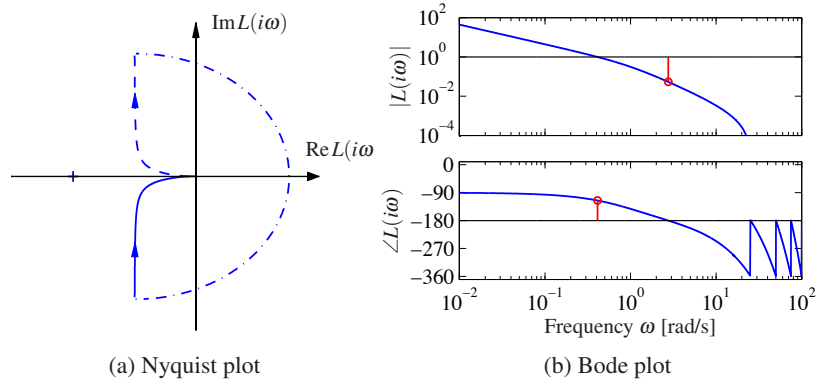

**Figure 11.5:** Integral control for AFM in tapping mode. An integral controller is designed based on the slope of the process transfer function at 0. The controller gives good robustness properties based on a very simple analysis.

The closed loop poles can thus be assigned arbitrary values by proper choice of the controller gains  $k_p$  and  $k_i$ . We illustrate the by an example.

### Example 11.3 Cruise control using PI feedback

Consider the problem of maintaining the speed of a car as it goes up a hill. In Example 6.14 we found that there was little difference between the linear and non-linear models when investigating PI control, provided that the throttle did not reach the saturation limits. A simple linear model of a car was given in Example 6.11:

$$\frac{d(v - v_e)}{dt} = -a(v - v_e) + b(u - u_e) - g\theta, \quad (11.7)$$

where  $v$  is the velocity of the car,  $u$  is the input from the engine throttle and  $\theta$  is the slope of the hill. The parameters were  $a = 0.0101$ ,  $b = 1.3203$ ,  $g = 9.8$ ,  $v_e = 20$  and  $u_e = 0.1616$ . This model will be used to find suitable parameters of a vehicle speed controller. The transfer function from throttle to velocity is a first-order system. Since the open loop dynamics is so slow ( $1/a \approx 100$  sec.), it is natural to specify a faster closed loop system by requiring that the closed loop system be of second-order with damping ratio  $\zeta$  and undamped natural frequency  $\omega_0$ . The controller gains are given by equation (??).

Figure 11.6 shows the velocity and the throttle for a car that initially moves on a horizontal road and encounters a hill with a slope of  $4^\circ$  at time  $t = 6$  s. To design a PI controller we choose  $\zeta = 1$  to obtain a response without overshoot, as shown in Figure 11.6a. The choice of  $\omega_0$  is a compromise between response speed and control actions: a large value gives a fast response, but it requires fast control action. The trade-off is illustrated in Figure 11.6b. The largest velocity error decreases with increasing  $\omega_0$ , but the control signal also changes more rapidly. In the simple model (11.7) it was assumed that the force responds instantaneously to throttle commands. For rapid changes there may be additional dynamics that have to be accounted for. There are also physical limitations to the rate of change of the



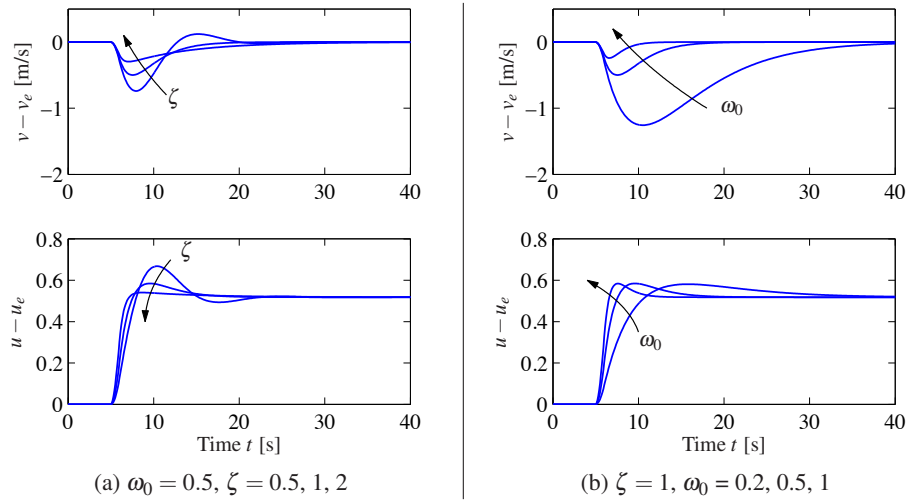

**Figure 11.6:** Cruise control using PI feedback. The step responses for the error and input illustrate the effect of parameters  $\zeta = 1$  and  $\omega_0$  on the response of a car with cruise control. The slope of the road changes linearly from  $0^\circ$  to  $4^\circ$  between  $t = 5$  and  $6$  s. (a) Responses for  $\omega_0 = 0.5$  and  $\zeta = 0.5, 1$  and  $2$ . Choosing  $\zeta = 1$  gives no overshoot in  $v$ . (b) Responses for  $\zeta = 1$  and  $\omega_0 = 0.2, 0.5$  and  $1.0$ .

force, which also restricts the admissible value of  $\omega_0$ . A reasonable choice of  $\omega_0$  is in the range  $0.5$ – $1.0$ . Notice in Figure 11.6 that even with  $\omega_0 = 0.2$  the largest velocity error is only  $1$  m/s.  $\nabla$

A PI controller can also be used for a process with second-order dynamics, but there will be restrictions on the possible locations of the closed loop poles. Using a PID controller, it is possible to control a system of second order in such a way that the closed loop poles have arbitrary locations; see Exercise 11.2.

Instead of finding a low-order model and designing controllers for them, we can also use a high-order model and attempt to place only a few dominant poles. An integral controller has one parameter, and it is possible to position one pole. Consider a process with the transfer function  $P(s)$ . The loop transfer function with an integral controller is  $L(s) = k_i P(s)/s$ . The roots of the closed loop characteristic polynomial are the roots of  $s + k_i P(s) = 0$ . Requiring that  $s = -a$  be a root, the controller gain should be chosen as

$$k_i = \frac{a}{P(-a)}. \quad (11.8)$$

The pole  $s = -a$  will be a dominant closed-loop pole if  $a$  is small. A similar approach can be applied to PI and PID controllers; see Exercise 11.3.

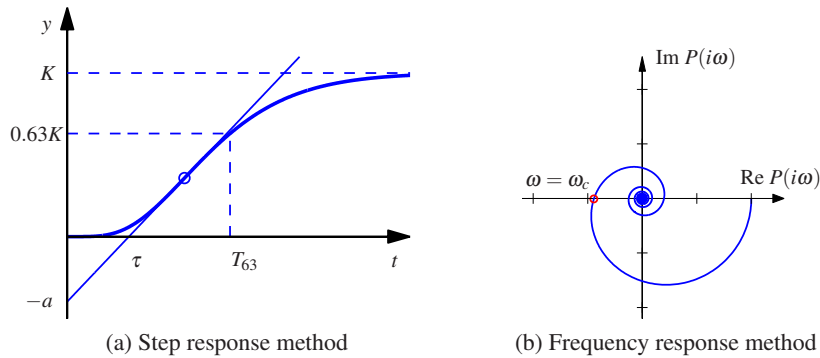

**Figure 11.7:** Ziegler–Nichols step and frequency response experiments. The open-loop unit step response in (a) is characterized by the parameters  $a$  and  $\tau$ . The frequency response method (b) characterizes process dynamics by the point where the Nyquist curve of the process transfer function first intersects the negative real axis and the frequency  $\omega_c$  where this occurs.

### 11.3 PID Tuning

Users of control systems are frequently faced with the task of adjusting the controller parameters to obtain a desired behavior. There are many different ways to do this. One approach is to go through the conventional steps of modeling and control design as described in the previous section. Since the PID controller has so few parameters, a number of special empirical methods have also been developed for direct adjustment of the controller parameters. The first tuning rules were developed by Ziegler and Nichols [ZN42]. Their idea was to perform a simple experiment, extract some features of process dynamics from the experiment and determine the controller parameters from the features.

#### Ziegler–Nichols' Tuning

In the 1940s, Ziegler and Nichols developed two methods for controller tuning based on simple characterization of process dynamics in the time and frequency domains.

The time domain method is based on a measurement of part of the open loop unit step response of the process, as shown in Figure 11.7a. The step response is measured by a *bump test*. The process is first brought to steady-state, the input is then changed by a suitable amount, the output is measured and scaled to correspond to a unit step input. Newton and Ziegler characterized the step response by only two parameters  $a$  and  $\tau$ , which are the intercepts of the steepest tangent of the step response with the coordinate axes. The parameter  $\tau$  is an approximation of the time delay of the system and  $a/\tau$  is the steepest slope of the step response. Notice that it is not necessary to wait until steady state is reached to be able to determine the parameters, it suffices to wait until the response has had an inflection point. The suggested controller parameters are given in Table 11.1. They were obtained by extensive simulation of a range of representative processes. A controller was

**Table 11.1:** Ziegler–Nichols tuning rules. (a) The step response methods give the parameters in terms of the intercept  $a$  and the apparent time delay  $\tau$ . (b) The frequency response method gives controller parameters in terms of *critical gain*  $k_c$  and *critical period*  $T_c$ .

Type	$k_p$	$T_i$	$T_d$	Type	$k_p$	$T_i$	$T_d$
P	$1/a$			P	$0.5k_c$		
PI	$0.9/a$	$3\tau$		PI	$0.4k_c$	$0.8T_c$	
PID	$1.2/a$	$2\tau$	$0.5\tau$	PID	$0.6k_c$	$0.5T_c$	$0.125T_c$

(a) Step response method                      (b) Frequency response method

tuned manually for each process, and an attempt was then made to correlate the controller parameters with  $a$  and  $\tau$ .

In the frequency domain method, a controller is connected to the process, the integral and derivative gains are set to zero and the proportional gain is increased until the system starts to oscillate. The critical value of the proportional gain  $k_c$  is observed together with the period of oscillation  $T_c$ . It follows from Nyquist's stability criterion that the loop transfer function  $L = k_c P(s)$  intersects the critical point at the frequency  $\omega_c = 2\pi/T_c$ . The experiment thus gives the point on the Nyquist curve of the process transfer function where the phase lag is  $180^\circ$ , as shown in Figure 11.7b.

The Ziegler–Nichols methods had a huge impact when they were introduced in the 1940s. The rules were simple to use and gave initial conditions for manual tuning. The ideas were adopted by manufacturers of controllers for routine use. The Ziegler–Nichols tuning rules unfortunately have two severe drawbacks: too little process information is used, and the closed loop systems that are obtained lack robustness.

The step response method can be improved significantly by characterizing the unit step response by the FOTD (First Order and Time Delay) model

$$P(s) = \frac{K}{1 + sT} e^{-\tau s}. \quad (11.9)$$

This model is commonly used to approximate the step response of systems with monotone step responses. The parameters of the model are obtained from a bump test as indicated in Figure 11.7a. The zero frequency gain  $K$  is the steady-state value of the unit step response. The time delay  $\tau$  is the intercept of the steepest tangent with the time axis, as in the Ziegler–Nichols method. The time  $T_{63}$  is the time where the output has reached 63% of its steady-state value and  $T$  is then given by  $T = T_{63} - \tau$ . Notice that it takes longer time to find an FOTD model than the Ziegler–Nichols model ( $a$  and  $\tau$ ) because to determine  $K$  it is necessary to wait until the steady state has been reached, see Figure 11.7a

The frequency response method can be improved by measuring more points on the Nyquist curve, e.g., the zero frequency gain  $K$  or the point where the process has a  $90^\circ$  phase lag. This latter point can be obtained by connecting an integral

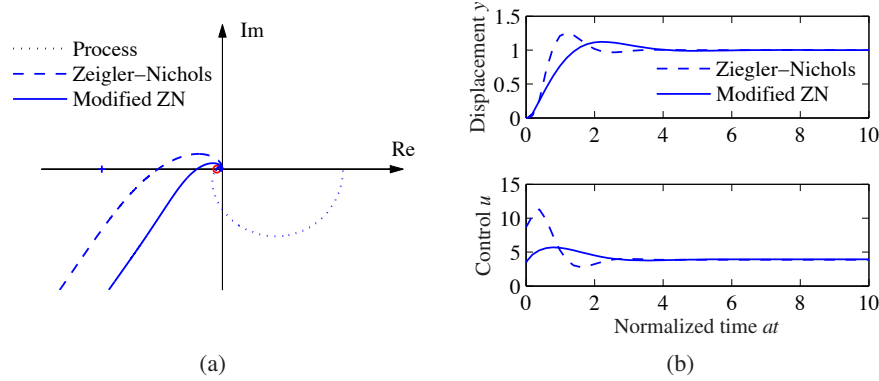

**Figure 11.8:** PI control of an AFM in tapping mode. Nyquist plots (a) and step responses (b) for PI control of the vertical motion of an atomic force microscope in tapping mode. Results with Ziegler–Nichols tuning are shown by dashed lines, and modified Ziegler–Nichols tuning is shown by solid lines. The Nyquist plot of the process transfer function is shown by dotted lines.

controller and increasing its gain until the system reaches the stability limit. The experiment can also be automated by using relay feedback, as will be discussed later in this section.

There are many versions of improved tuning rules. As an illustration we give the following rules for PI control, based on [ÅH05]:

$$k_p = \frac{0.15\tau + 0.35T}{K\tau} \left( \frac{0.9T}{K\tau} \right), \quad k_i = \frac{0.46\tau + 0.02T}{K\tau^2} \left( \frac{0.3T}{K\tau^2} \right), \quad (11.10a)$$

$$k_p = 0.22k_c - \frac{0.07}{K} \left( 0.4k_c \right), \quad k_i = \frac{0.16k_c}{T_c} + \frac{0.62}{KT_c} \left( \frac{0.5k_c}{T_c} \right). \quad (11.10b)$$

The values for the Ziegler–Nichols rule from Table 11.2a are given in parentheses. Notice that the improved formulas typically give lower controller gains than the Ziegler–Nichols method. The integral gain is higher for systems where the dynamics are delay-dominated,  $\tau \gg T$ .

#### Example 11.4 Atomic force microscope in tapping mode

A simplified model of the dynamics of the vertical motion of an atomic force microscope in tapping mode was discussed in Example 11.2. The transfer function is normalized by choosing  $1/a$  as the time unit, yielding

$$P(s) = \frac{1 - e^{-sT_n}}{sT_n(s+1)},$$

where  $T_n = 2n\pi a/\omega_0 = 2n\pi\zeta$ . The Nyquist plot of the transfer function is shown (dotted line) in Figure 11.8a for  $\zeta = 0.002$  and  $n = 20$ . The first intersection with the real axis occurs at  $\text{Re } s = -0.0461$  for  $\omega_c = 13.1$ . The critical gain is thus  $k_c = 21.7$  and the critical period is  $T_c = 0.48$ . Using the Ziegler–Nichols tuning rule, we find the parameters  $k_p = 8.87$  and  $k_i = 22.6$  ( $T_i = 0.384$ ) for a PI controller.

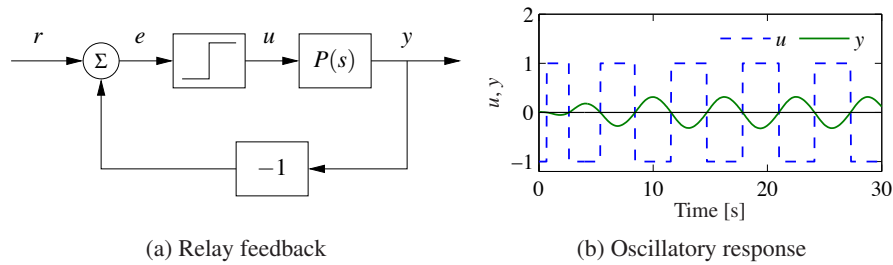

**Figure 11.9:** Block diagram of a process with relay feedback (a) and typical signals (b). The process output  $y$  is a solid line, and the relay output  $u$  is a dashed line. Notice that the signals  $u$  and  $y$  have opposite phases.

With this controller the stability margin is  $s_m = 0.31$ , which is quite small. The step response of the controller is shown (dashed lines) in Figure 11.8. Notice in particular that there is a large overshoot in the control signal.

The modified Ziegler–Nichols rule (11.10b) gives the controller parameters  $k_p = 3.47$  and  $k_i = 8.73$  ( $T_i = 0.459$ ) and the stability margin becomes  $s_m = 0.61$ . The step response with this controller is shown in Figure 11.8. A comparison of the responses obtained with the original Ziegler–Nichols rule shows that the overshoot has been reduced. Notice that the control signal reaches its steady-state value almost instantaneously. It follows from Example 11.2 that a pure integral controller has the normalized gain  $k_i = 1/(2 + T_n) = 0.44$  which is more than an order of magnitude smaller than the integral gain of the PI controller. ▽

### Relay Feedback

The Ziegler–Nichols frequency response method increases the gain of a proportional controller until oscillation to determine the critical gain  $k_c$  and the corresponding critical period  $T_c$  or, equivalently, the point where the Nyquist curve intersects the negative real axis. One way to obtain this information automatically is to connect the process in a feedback loop with a nonlinear element having a relay function as shown in Figure 11.9a. For many systems there will then be an oscillation, as shown in Figure 11.9b, where the relay output  $u$  is a square wave and the process output  $y$  is close to a sinusoid. Moreover, the fundamental sinusoidal components of the input and the output are  $180^\circ$  out of phase, which means that the system oscillates with the critical period  $T_c$ . Notice that an oscillation with constant period is established quickly.

To determine the critical gain  $k_c$  we expand the square wave relay output in a Fourier series. Notice in the figure that the process output is practically sinusoidal because the process attenuates higher harmonics effectively. It is then sufficient to consider only the first harmonic component of the input. Letting  $d$  be the relay amplitude, the first harmonic of the square wave input has amplitude  $4d/\pi$ . If  $a$  is the amplitude of the process output, the process gain at the critical frequency

$\omega_c = 2\pi/T_c$  is  $|P(i\omega_c)| = \pi a/(4d)$  and the critical gain is

$$k_c = \frac{4d}{a\pi}. \quad (11.11)$$

Having obtained the critical gain  $k_c$  and the critical period  $T_c$ , the controller parameters can then be determined using the Ziegler–Nichols rules. Improved tuning can be obtained by fitting a model to the data obtained from the relay experiment.

The relay experiment can be automated. Since the amplitude of the oscillation is proportional to the relay output, it is easy to control it by adjusting the relay output. *Automatic tuning* based on relay feedback is used in many commercial PID controllers. Tuning is accomplished simply by pushing a button that activates relay feedback. The relay amplitude is automatically adjusted to keep the oscillations sufficiently small, and the relay feedback is replaced by a PID controller as soon as the tuning is finished.

## 11.4 Integrator Windup

Many aspects of a control system can be understood from linear models. There are, however, some nonlinear phenomena that must be taken into account. These are typically limitations in the actuators: a motor has limited speed, a valve cannot be more than fully opened or fully closed, etc. For a system that operates over a wide range of conditions, it may happen that the control variable reaches the actuator limits. When this happens, the feedback loop is broken and the system runs in open loop because the actuator remains at its limit independently of the process output as long as the actuator remains saturated. The integral term will also build up since the error is typically nonzero. The integral term and the controller output may then become very large. The control signal will then remain saturated even when the error changes, and it may take a long time before the integrator and the controller output come inside the saturation range. The consequence is that there are large transients. This situation is referred to as *integrator windup*, illustrated in the following example.

### Example 11.5 Cruise control

The windup effect is illustrated in Figure 11.10a, which shows what happens when a car encounters a hill that is so steep ( $6^\circ$ ) that the throttle saturates when the cruise controller attempts to maintain speed. When encountering the slope at time  $t = 5$ , the velocity decreases and the throttle increases to generate more torque. However, the torque required is so large that the throttle saturates. The error decreases slowly because the torque generated by the engine is just a little larger than the torque required to compensate for gravity. The error is large and the integral continues to build up until the error reaches zero at time 30, but the controller output is still larger than the saturation limit and the actuator remains saturated. The integral term starts to decrease, and the velocity settles to the desired value at time  $t = 40$ . Also notice the large overshoot.  $\nabla$

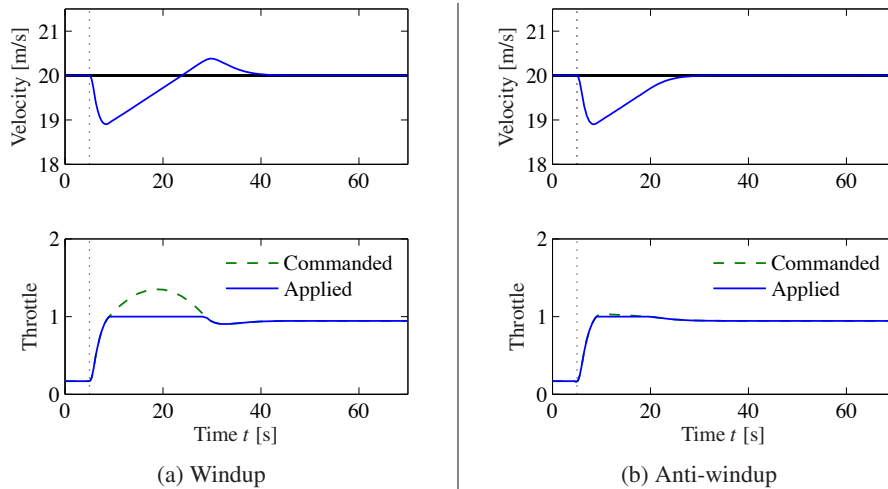

**Figure 11.10:** Simulation of PI cruise control with windup (a) and anti-windup (b). The figure shows the speed  $v$  and the throttle  $u$  for a car that encounters a slope that is so steep that the throttle saturates. The controller output is a dashed line. The controller parameters are  $k_p = 0.5$  and  $k_i = 0.1$ . The anti-windup compensator eliminates the overshoot by preventing the error for building up in the integral term of the controller.

There are many methods to avoid windup. One method is illustrated in Figure 11.11: the system has an extra feedback path that is generated by measuring the actual actuator output, or the output of a mathematical model of the saturating actuator, and forming an error signal  $e_s$  as the difference between the output of the controller  $v$  and the actuator output  $u$ . The signal  $e_s$  is fed to the input of the integrator through gain  $k_t$ . The signal  $e_s$  is zero when there is no saturation and the extra feedback loop has no effect on the system. When the actuator saturates, the signal  $e_s$  is fed back to the integrator in such a way that  $e_s$  goes toward zero. This implies that controller output is kept close to the saturation limit. The controller output will then change as soon as the error changes sign and integral windup is avoided.

The rate at which the controller output is reset is governed by the feedback gain  $k_t$ ; a large value of  $k_t$  gives a short reset time. The parameter  $k_t$  cannot be too large because measurement noise can then cause an undesirable reset. A reasonable choice is to choose  $k_t$  as a multiple of  $1/T_i = k_i/k_p$ .

The anti-windup scheme in Figure 11.11 assumes that the actuator output is available to the controller, when this is not the case we will instead use a model of the actuator as will be done in Section 11.5.

We illustrate how integral windup can be avoided by investigating the cruise control system.

### Example 11.6 Cruise control with anti-windup

Figure 11.10b shows what happens when a controller with anti-windup is applied to the system simulated in Figure 11.10a. Because of the feedback from the ac-

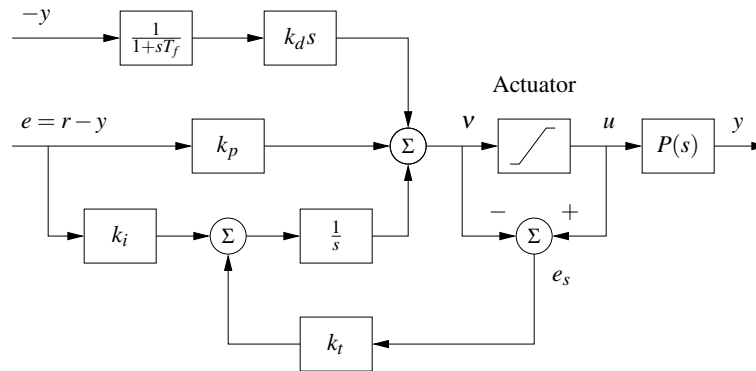

**Figure 11.11:** PID controller with a filtered derivative and anti-windup. The input to the integrator ( $1/s$ ) consists of the error term plus a “reset” based on input saturation. If the actuator is not saturated, then  $e_s = u - v$ , otherwise  $e_s$  will decrease the integrator input to prevent windup.

tuator model, the output of the integrator is quickly reset to a value such that the controller output is at the saturation limit. The behavior is drastically different from that in Figure 11.10a and the large overshoot is avoided. The tracking gain used in the simulation is  $k_t = 2$  which is an order of magnitude larger than  $1/T_i = k_i/k_p = 0.2$ . ▽

### Manual Control

Automatic control is often combined with manual control. This can be accomplished by providing the controller with a switch from manual to automatic. Manual control is typically actuated using buttons for increasing and decreasing the control signal. The control signal increases at constant rate when pushing the increase button and it decreases at constant rate when the decrease button is pushed. There are more sophisticated schemes where the rate increases when the switch is pushed a longer time, like the search mechanism in an iPod.

Care has to be taken to avoid transients when switching modes. This can be accomplished by the arrangement shown in Figure 11.12 where the integrator for the PI controller is used both for manual and automatic control. In automatic mode (A) the switch S connects the error signal to the input of the integrator. In manual mode (M) the switch disconnects the error signal and connects the integral to the increase-decrease buttons in manual mode. The switching transients will be small since the output of the integrator is the same in manual and automatic mode. There proportional term will create a switching transient if the error  $e$  is not zero when the mode is changed.

### Controller with a Tracking Mode

When continuous control is combined with logic it is important that the controller state is handled properly when switching modes. In the controller with manual



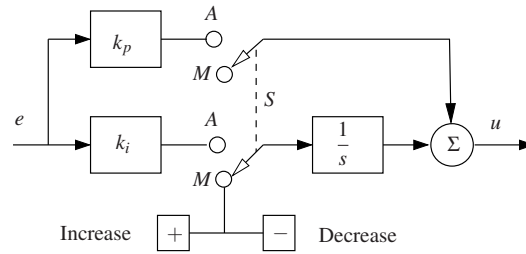

**Figure 11.12:** Block diagram of a PI controller that can switch between manual and automatic control. Automatic mode is indicated by A and manual mode by M. Manual control is executed by the buttons marked + and – which increase or decrease the control signal.

and automatic control in Figure 11.12 the problem was solved by using the same integrator for manual and automatic control. This ensures that there will be no switching transients. A general approach is to introduce a *tracking mode* in the controller.

A block diagram of a controller with a tracking mode is shown in Figure 11.13. The controller has modes for automatic control and tracking, selected by a switch. In the automatic control mode (A) the controller works as a normal controller which generates the control signal  $u$  from the reference  $r$  and the process output  $y$ . The controller has two degrees of freedom and is governed by the differential equation

$$a(p)u(t) = b(p)r(t) - c(p)y(t). \tag{11.12}$$

In tracking mode (T) the output  $u$  of the controller is equal to the tracking signal  $w$  and the behavior is governed by the differential equation

$$a_o(p)z(t) = b(p)r(t) - c(p)y(t) + (a_o(p) - a(p))u(t), \tag{11.13}$$

where the polynomial  $a_o(s)$  is stable, monic, and of the same degree as  $a(s)$ . If the controller has integral action we have

$$a(0) = 0, \quad b(0) = c(0), \quad a_o(0) \neq 0.$$

In steady state where all signals are constant we have  $w = u$ . The controller can

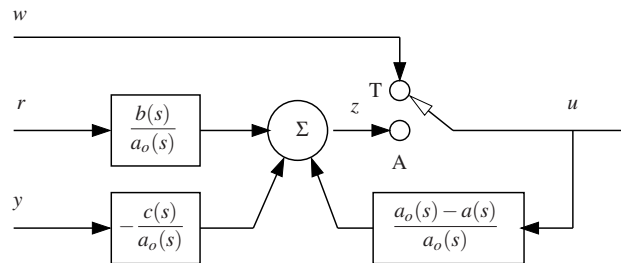

**Figure 11.13:** Block diagram of a controller with a tracking mode. The controller has three continuous input signals: reference  $r$ , process output  $y$  and tracking signal  $w$ , and a switch for selecting automatic A control or tracking T.

then be switched to automatic mode without transients. The polynomial  $a_o(s)$  determines how quickly the state is reached. By continuity we have  $w(t) \approx u(t)$  for slowly varying signals.

When the controller is switched to automatic we set  $z = u$  and equation (11.13) becomes

$$a_o(p)u(t) = b(p)r(t) - c(p)y(t) + (a_o(p) - a(p))u(t),$$

which is identical to (11.12). We will illustrate with an example.

### Example 11.7 PI controller with tracking mode

A PI controller with two degrees of freedom has the input/output relation

$$u(t) = k_p(\beta r(t) - y(t)) + k_i \int_0^t (r(\tau) - y(\tau)) d\tau,$$

which is equivalent to the differential equation

$$\frac{du}{dt} = \left(k_p\beta \frac{dr}{dt} + k_i r\right) - \left(k_p \frac{dy}{dt} + k_i y\right).$$

In tracking mode the controller is described by

$$\frac{dz}{dt} + a_o z = \left(k_p\beta \frac{dr}{dt} + r\right) - \left(k_p \frac{dy}{dt} + k_i y\right) + a_o u$$

(see Figure 11.13). A convenient way to combine automatic and tracking mode is to represent the controller as

$$\begin{aligned} \frac{dz}{dt} &= \left(k_p\beta \frac{dr}{dt} + r\right) - \left(k_p \frac{dy}{dt} + k_i y\right) + a_o(u - z) \\ u &= \begin{cases} z & \text{automatic mode} \\ w & \text{tracking mode} \end{cases} \end{aligned}$$

In this representation the controller is a first order system with one state  $z$  whose dynamics has the characteristic polynomial  $s + a_o$ . In automatic mode the controller output is equal to the state  $z$ . In the tracking mode the output is equal to the external tracking signal  $w$  and the controller state  $z$  tracks the signal  $w$ .  $\nabla$

## 11.5 Implementation

There are many practical issues that have to be considered when implementing PID controllers. They have been developed over time based on practical experience. In this section we consider some of the most common. Similar considerations also apply to other types of controllers.

### Filtering the Derivative

A drawback with derivative action is that an ideal derivative has high gain for high-frequency signals. This means that high-frequency measurement noise will

generate large variations in the control signal. The effect of measurement noise may be reduced by replacing the term  $k_d s$  by  $k_d s / (1 + sT_f)$ , which can be interpreted as an ideal derivative of a low-pass filtered signal. The time constant of the filter is typically chosen as  $T_f = (k_d/k_p)/N = T_d/N$ , with  $N$  in the range 5–20. Filtering is obtained automatically if the derivative is implemented by taking the difference between the signal and its filtered version as shown in Figure 11.3b; see also equation (11.5)).

Instead of filtering just the derivative, it is also possible to use an ideal controller and filter the measured signal. Choosing a second order Butterworth filter the transfer function the controller with the filter becomes

$$C(s) = k_p \left( 1 + \frac{1}{sT_i} + sT_d \right) \frac{1}{1 + sT_f + (sT_f)^2/2}. \quad (11.14)$$

### Setpoint Weighting

Figure 11.1 shows two configurations of a PID controller. The system in Figure 11.1a has a controller with *error feedback* where proportional, integral and derivative action acts on the error. In the simulation of PID controllers in Figure 11.2c there is a large initial peak in the control signal, which is caused by the derivative of the reference signal. The peak can be avoided by using the controller in Figure 11.1b, where proportional and derivative action acts only on the process output. An intermediate form is given by

$$u = k_p(\beta r - y) + k_i \int_0^t (r(\tau) - y(\tau)) d\tau + k_d \left( \gamma \frac{dr}{dt} - \frac{dy}{dt} \right), \quad (11.15)$$

where the proportional and derivative actions act on fractions  $\beta$  and  $\gamma$  of the reference. Integral action has to act on the error to make sure that the error goes to zero in steady state. The closed loop systems obtained for different values of  $\beta$  and  $\gamma$  respond to load disturbances and measurement noise in the same way. The response to reference signals is different because it depends on the values of  $\beta$  and  $\gamma$ , which are called *reference weights* or *setpoint weights*. We illustrate the effect of setpoint weighting by an example.

#### Example 11.8 Cruise control with setpoint weighting

Consider the PI controller for the cruise control system derived in Example 11.3. Figure 11.14 shows the effect of setpoint weighting on the response of the system to a reference signal. With  $\beta = 1$  (error feedback) there is an overshoot in velocity and the control signal (throttle) is initially close to the saturation limit. There is no overshoot with  $\beta = 0$  and the control signal is much smaller, clearly a much better drive comfort. The frequency responses gives another view of the same effect. The parameter  $\beta$  is typically in the range 0–1, and  $\gamma$  is normally zero to avoid large transients in the control signal when the reference is changed.  $\nabla$

The controller given by equation (11.15) is a special case of the general controller structure having two degrees of freedom, which was discussed in Section 8.5.

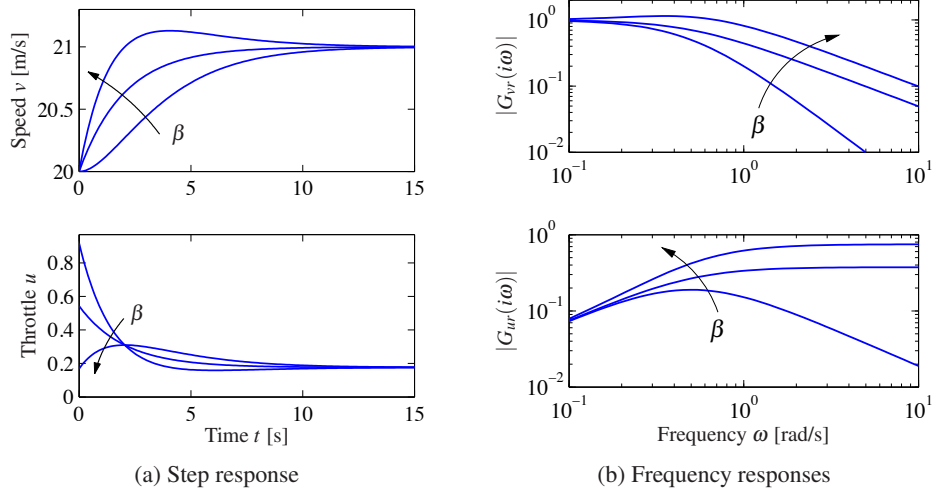

**Figure 11.14:** Time and frequency responses for PI cruise control with setpoint weighting. Step responses are shown in (a), and the gain curves of the frequency responses in (b). The controller gains are  $k_p = 0.74$  and  $k_i = 0.19$ . The setpoint weights are  $\beta = 0, 0.5$  and  $1$ , and  $\gamma = 0$ .

### Implementation Based on Operational Amplifiers

PID controllers have been implemented in different technologies. Figure 11.15 shows how PI and PID controllers can be implemented by feedback around operational amplifiers.

To show that the circuit in Figure 11.15b is a PID controller we will use the approximate relation between the input voltage  $e$  and the output voltage  $u$  of the operational amplifier derived in Example 9.3,

$$u = -\frac{Z_2}{Z_1}e.$$

In this equation  $Z_1$  is the impedance between the negative input of the amplifier

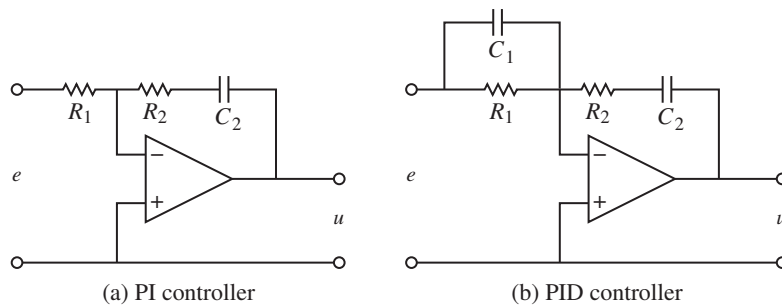

**Figure 11.15:** Schematic diagrams for PI and PID controllers using op amps. The circuit in (a) uses a capacitor in the feedback path to store the integral of the error. The circuit in (b) adds a filter on the input to provide derivative action.

and the input voltage  $e$ , and  $Z_2$  is the impedance between the zero input of the amplifier and the output voltage  $u$ . The impedances are given by

$$Z_1(s) = \frac{R_1}{1 + R_1 C_1 s}, \quad Z_2(s) = R_2 + \frac{1}{C_2 s},$$

and we find the following relation between the input voltage  $e$  and the output voltage  $u$ :

$$u = -\frac{Z_2}{Z_1} e = -\frac{R_2 (1 + R_1 C_1 s)(1 + R_2 C_2 s)}{R_1 R_2 C_2 s} e.$$

This is the input/output relation for a PID controller of the form (11.1) with parameters

$$k_p = \frac{R_1 C_1 + R_2 C_2}{R_1 C_2}, \quad T_i = R_1 C_1 + R_2 C_2, \quad T_d = \frac{R_1 R_2 C_1 C_2}{R_1 C_1 + R_2 C_2}.$$

The corresponding results for a PI controller are obtained by setting  $C_1 = 0$  (removing the capacitor).

### Computer Implementation

In this section we briefly describe how a PID controller may be implemented using a computer. The computer typically operates periodically, with signals from the sensors sampled and converted to digital form by the A/D converter, and the control signal computed and then converted to analog form for the actuators. The sequence of operation is as follows:

1. Wait for clock interrupt
2. Read input from sensor
3. Compute control signal
4. Send output to the actuator
5. Update controller state
6. Repeat

Notice that an output is sent to the actuators as soon as it is available. The time delay is minimized by making the calculations in step 3 as short as possible and performing all updates after the output is commanded. This simple way of reducing the latency is, unfortunately, seldom used in commercial systems.

As an illustration we consider the PID controller in Figure 11.11, which has a filtered derivative, setpoint weighting and protection against integral windup (anti-windup). The controller is a continuous-time dynamical system. To implement it using a computer, the continuous-time system has to be approximated by a discrete-time system.

In Figure 11.11, the signal  $v$  is the sum of the proportional, integral and derivative terms, and the controller output is  $u = \text{sat}(v)$ , where  $\text{sat}$  is the saturation function that models the actuator. The proportional term  $P = k_p(\beta r - y)$  is implemented simply by replacing the continuous variables with their sampled versions. Hence

$$P(t_k) = k_p(\beta r(t_k) - y(t_k)), \quad (11.16)$$

where  $\{t_k\}$  denotes the sampling instants, i.e., the times when the computer reads its input. We let  $h$  represent the sampling time, so that  $t_{k+1} = t_k + h$ . The integral

term is obtained by approximating the integral with a sum,

$$I(t_{k+1}) = I(t_k) + k_i h e(t_k) + \frac{h}{T_i} (\text{sat}(v) - v), \quad (11.17)$$

where  $T_i = h/k_i$  represents the anti-windup term. The filtered derivative term  $D$  is given by the differential equation

$$T_f \frac{dD}{dt} + D = -k_d \dot{y}.$$

Approximating the derivative with a backward difference gives

$$T_f \frac{D(t_k) - D(t_{k-1})}{h} + D(t_k) = -k_d \frac{y(t_k) - y(t_{k-1})}{h},$$

which can be rewritten as

$$D(t_k) = \frac{T_f}{T_f + h} D(t_{k-1}) - \frac{k_d}{T_f + h} (y(t_k) - y(t_{k-1})). \quad (11.18)$$

The advantage of using a backward difference is that the parameter  $T_f/(T_f + h)$  is nonnegative and less than 1 for all  $h > 0$ , which guarantees that the difference equation is stable. Reorganizing equations (11.16)–(11.18), the PID controller can be described by the following pseudocode:

```
% Precompute controller coefficients
bi=ki*h
ad=Tf/(Tf+h)
bd=kd/(Tf+h)
br=h/Tt

% Control algorithm - main loop
while (running) {
    r=adin(ch1)           % read setpoint from ch1
    y=adin(ch2)           % read process variable from ch2
    P=kp*(b*r-y)         % compute proportional part
    D=ad*D-bd*(y-yold)   % compute derivative part
    v=P+I+D               % compute temporary output
    u=sat(v, ulow, uhigh) % simulate actuator saturation
    daout(ch1)            % set analog output ch1
    I=I+bi*(r-y)+br*(u-v) % update integral state
    yold=y                % update derivative state
    sleep(h)              % wait until next update interval
}
```

Precomputation of the coefficients  $bi$ ,  $ad$ ,  $bd$  and  $br$  saves computer time in the main loop. These calculations have to be done only when controller parameters are changed. The main loop is executed once every sampling period. The program has three states:  $yold$ ,  $I$ , and  $D$ . One state variable can be eliminated at the cost of less readable code. The latency between reading the analog input and setting the analog output consists of four multiplications, four additions and evaluation of the `sat` function. All computations can be done using fixed-point calculations

if necessary. Notice that the code computes the filtered derivative of the process output and that it has setpoint weighting and anti-windup protection.

## 11.6 Further Reading

The history of PID control is very rich and stretches back to the beginning of the foundation of control theory. Very readable treatments are given by Bennett [Ben79, Ben93] and Mindel [Min02]. The Ziegler–Nichols rules for tuning PID controllers, first presented in 1942 [ZN42], were developed based on extensive experiments with pneumatic simulators and Vannevar Bush’s differential analyzer at MIT. An interesting view of the development of the Ziegler–Nichols rules is given in an interview with Ziegler [Bli90]. An industrial perspective on PID control is given in [Bia95], [Shi96] and [YH91] and in the paper [DM02] cited in the beginning of this chapter. A comprehensive presentation of PID control is given in [ÅH05]. Interactive learning tools for PID control can be downloaded from <http://www.calerga.com/contrib>.

## Exercises

**11.1** (Ideal PID controllers) Consider the systems represented by the block diagrams in Figure 11.1. Assume that the process has the transfer function  $P(s) = b/(s + a)$  and show that the transfer functions from  $r$  to  $y$  are

$$(a) \quad G_{yr}(s) = \frac{bk_d s^2 + bk_p s + bk_i}{(1 + bk_d)s^2 + (a + bk_p)s + bk_i},$$

$$(b) \quad G_{yr}(s) = \frac{bk_i}{(1 + bk_d)s^2 + (a + bk_p)s + bk_i}.$$

Pick some parameters and compare the step responses of the systems.

**11.2** Consider a second-order process with the transfer function

$$P(s) = \frac{b}{s^2 + a_1 s + a_2}.$$

The closed loop system with a PI controller is a third-order system. Show that it is possible to position the closed loop poles as long as the sum of the poles is  $-a_1$ . Give equations for the parameters that give the closed loop characteristic polynomial

$$(s + \alpha_0)(s^2 + 2\zeta_0 \omega_0 s + \omega_0^2).$$

**11.3** Consider a system with the transfer function  $P(s) = (s + 1)^{-2}$ . Find an integral controller that gives a closed loop pole at  $s = -a$  and determine the value of  $a$  that maximizes the integral gain. Determine the other poles of the system

and judge if the pole can be considered dominant. Compare with the value of the integral gain given by equation (11.6).

**11.4** (Ziegler–Nichols tuning) Consider a system with transfer function  $P(s) = e^{-s}/s$ . Determine the parameters of P, PI and PID controllers using Ziegler–Nichols step and frequency response methods. Compare the parameter values obtained by the different rules and discuss the results.

**11.5** (Vehicle steering) Design a proportional-integral controller for the vehicle steering system that gives the closed loop characteristic polynomial

$$s^3 + 2\omega_0 s^2 + 2\omega_0 s + \omega_0^3.$$

**11.6** (Congestion control) A simplified flow model for TCP transmission is derived in [HMTG00, LPD02]. The linearized dynamics are modeled by the transfer function

$$G_{qp}(s) = \frac{b}{(s+a_1)(s+a_2)} e^{-s\tau_e},$$

which describes the dynamics relating the expected queue length  $q$  to the expected packet drop  $p$ . The parameters are given by  $a_1 = 2N^2/(c\tau_e^2)$ ,  $a_2 = 1/\tau_e$  and  $b = c^2/(2N)$ . The parameter  $c$  is the bottleneck capacity,  $N$  is the number of sources feeding the link and  $\tau_e$  is the round-trip delay time. Use the parameter values  $N = 75$  sources,  $C = 1250$  packets/s and  $\tau_e = 0.15$  and find the parameters of a PI controller using one of the Ziegler–Nichols rules and the corresponding improved rule. Simulate the responses of the closed loop systems obtained with the PI controllers.

**11.7** (Motor drive) Consider the model of the motor drive in Exercise 3.10. Develop an approximate second-order model of the system and use it to design an ideal PD controller that gives a closed loop system with eigenvalues in  $\zeta\omega_0 \pm i\omega_0\sqrt{1-\zeta^2}$ . Add low-pass filtering as shown in equation (11.14) and explore how large  $\omega_0$  can be made while maintaining a good stability margin. Simulate the closed loop system with the chosen controller and compare the results with the controller based on state feedback in Exercise 7.12.

**11.8** Consider the system in Exercise 11.7 investigate what happens if the second-order filtering of the derivative is replaced by a first-order filter.

**11.9** (Tuning rules) Apply the Ziegler–Nichols and the modified tuning rules to design PI controllers for systems with the transfer functions

$$P_1 = \frac{e^{-s}}{s}, \quad P_2 = \frac{e^{-s}}{s+1}, \quad P_3 = e^{-s}.$$

Compute the stability margins and explore any patterns.

**11.10** (Windup and anti-windup) Consider a PI controller of the form  $C(s) = 1 + 1/s$  for a process with input that saturates when  $|u| > 1$ , and whose linear dynamics are given by the transfer function  $P(s) = 1/s$ . Simulate the response of



the system to step changes in the reference signal of magnitude 1, 2 and 3. Repeat the simulation when the windup protection scheme in Figure 11.11 is used.

**11.11** (Windup protection by conditional integration) Many methods have been proposed to avoid integrator windup. One method called *conditional integration* is to update the integral only when the error is sufficiently small. To illustrate this method we consider a system with PI control described by

$$\frac{dx_1}{dt} = u, \quad u = \text{sat}_{u_0}(k_p e + k_i x_2), \quad \frac{dx_2}{dt} = \begin{cases} e & \text{if } |e| < e_0 \\ 0 & \text{if } |e| \geq e_0, \end{cases}$$

where  $e = r - x$ . Plot the phase portrait of the system for the parameter values  $k_p = 1$ ,  $k_i = 1$ ,  $u_0 = 1$  and  $e_0 = 1$  and discuss the properties of the system. The example illustrates the difficulties of introducing ad hoc nonlinearities without careful analysis.



---

## Chapter Twelve

### Frequency Domain Design

*Sensitivity improvements in one frequency range must be paid for with sensitivity deteriorations in another frequency range, and the price is higher if the plant is open-loop unstable. This applies to every controller, no matter how it was designed.*

Gunter Stein in the inaugural IEEE Bode Lecture, 1989 [Ste03].

In this chapter we continue to explore the use of frequency domain techniques with a focus on the design of feedback systems. We begin with a more thorough description of the performance specifications for control systems and then introduce the concept of “loop shaping” as a mechanism for designing controllers in the frequency domain. We also introduce some fundamental limitations to performance for systems with time delays and right half-plane poles and zeros.

#### 12.1 Sensitivity Functions

In the previous chapter, we considered the use of proportional-integral-derivative (PID) feedback as a mechanism for designing a feedback controller for a given process. In this chapter we will expand our approach to include a richer repertoire of tools for shaping the frequency response of the closed loop system.

One of the key ideas in this chapter is that we can design the behavior of the closed loop system by focusing on the open loop transfer function. This same approach was used in studying stability using the Nyquist criterion: we plotted the Nyquist plot for the *open* loop transfer function to determine the stability of the *closed* loop system. From a design perspective, the use of loop analysis tools is very powerful: since the loop transfer function is  $L = PC$ , if we can specify the desired performance in terms of properties of  $L$ , we can directly see the impact of changes in the controller  $C$ . This is much easier, for example, than trying to reason directly about the tracking response of the closed loop system, whose transfer function is given by  $G_{yr} = PC/(1 + PC)$ .

We will start by investigating some key properties of the feedback loop. A block diagram of a basic feedback loop is shown in Figure 12.1. The system loop is composed of two components: the process and the controller. The controller itself has two blocks: the feedback block  $C$  and the feedforward block  $F$ . There are two disturbances acting on the process, the load disturbance  $v$  and the measurement noise  $w$ . The load disturbance represents disturbances that drive the process away from its desired behavior, while the measurement noise represents disturbances that corrupt information about the process given by the sensors. For example in

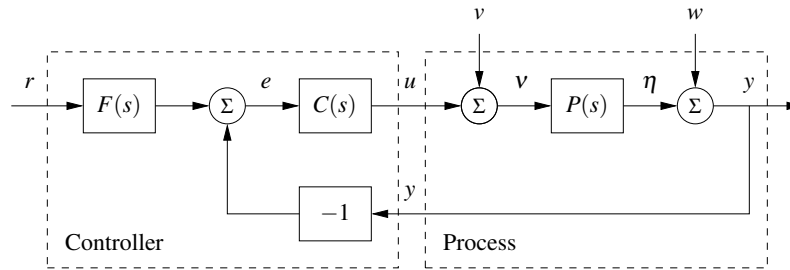

**Figure 12.1:** Block diagram of a basic feedback loop with two degrees of freedom. The controller has a feedback block  $C$  and a feedforward block  $F$ . The external signals are the reference signal  $r$ , the load disturbance  $v$  and the measurement noise  $w$ . The process output is  $\eta$ , and the control signal is  $u$ .

cruise control the major load disturbance is changes in the slope of the road and measurement noise is caused by the electronics that convert pulses measured on a rotating shaft to a velocity signal. The load disturbances typically have low frequencies, lower than the servo bandwidth, while measurement noise typically has higher frequencies. In the figure, the load disturbance is assumed to act on the process input. This is a simplification since disturbances often enter the process in many different ways, but it allows us to streamline the presentation without significant loss of generality.

The process output  $\eta$  is the real variable that we want to control. Control is based on the measured signal  $y$ , where the measurements are corrupted by measurement noise  $w$ . The process is influenced by the controller via the control variable  $u$ . The process is thus a system with three inputs—the control variable  $u$ , the load disturbance  $v$  and the measurement noise  $w$ —and one output—the measured signal  $y$ . The controller is a system with two inputs and one output. The inputs are the measured signal  $y$  and the reference signal  $r$ , and the output is the control signal  $u$ . Note that the control signal  $u$  is an input to the process and the output of the controller, and that the measured signal  $y$  is the output of the process and an input to the controller.

The feedback loop in Figure 12.1 is influenced by three external signals, the reference  $r$ , the load disturbance  $v$  and the measurement noise  $w$ . Any of the remaining signals can be of interest in controller design, depending on the particular application. Since the system is linear, the relations between the inputs and the interesting signals can be expressed in terms of the transfer functions. The following

relations are obtained from the block diagram in Figure 12.1:

$$\begin{pmatrix} y \\ \eta \\ v \\ u \\ e \end{pmatrix} = \begin{pmatrix} \frac{PCF}{1+PC} & \frac{P}{1+PC} & \frac{1}{1+PC} \\ \frac{PCF}{1+PC} & \frac{P}{1+PC} & \frac{-PC}{1+PC} \\ \frac{CF}{1+PC} & \frac{1}{1+PC} & \frac{-C}{1+PC} \\ \frac{CF}{1+PC} & \frac{-PC}{1+PC} & \frac{-C}{1+PC} \\ \frac{F}{1+PC} & \frac{-P}{1+PC} & \frac{-1}{1+PC} \end{pmatrix} \begin{pmatrix} r \\ v \\ w \end{pmatrix}. \quad (12.1)$$

In addition, we can write the transfer function for the error between the reference  $r$  and the output  $\eta$  (not an explicit signal in the diagram), which satisfies

$$\varepsilon = r - \eta = \left(1 - \frac{PCF}{1+PC}\right)r + \frac{-P}{1+PC}v + \frac{PC}{1+PC}w.$$

Notice that many of the transfer functions in (12.1) are the same. Only four transfer functions are required to describe how the system reacts to load disturbances and measurement noise, three additional transfer functions are required to describe how the system responds to reference signals.

The special case of  $F = 1$  is called a system with (pure) *error feedback* because all control actions are based on feedback from the error. In this case the system (12.1) is completely characterized by four transfer functions, which are called the sensitivity functions:

$$\begin{aligned} S &= \frac{1}{1+PC} && \text{sensitivity function} && PS &= \frac{P}{1+PC} && \text{load sensitivity function} \\ T &= \frac{PC}{1+PC} && \text{complementary sensitivity function} && CS &= \frac{C}{1+PC} && \text{noise sensitivity function} \end{aligned} \quad (12.2)$$

These transfer functions and their equivalent systems are called the *Gang of Four*. The load sensitivity function is sometimes called the input sensitivity function and the noise sensitivity function is sometimes called the output sensitivity function. These transfer functions have many interesting properties that will be discussed in detail in the rest of the chapter. Good insight into these properties is essential in understanding the performance of feedback systems for the purposes of both analysis and design. The transfer functions are also used to formulate requirements on the closed loop system.

When  $F \neq 1$  there are three additional transfer functions in (12.1).

$$PS = \frac{P}{1+PC}, \quad CSF = \frac{PCT}{1+PC}, \quad TF = \frac{PCF}{1+PC} \quad (12.3)$$

To summarize we find that the closed loop system can be characterized by seven transfer functions given by (12.2) and (12.3), which we call the *Gang of Seven*.

The closed loop system is stable if all transfer functions (12.2) are stable, which is called *internal stability*. If there are no pole-zero cancellations in the product  $PC$  the closed loop system is stable if the rational function  $1 + PC$  has all its zeros in the left half plane.

Analyzing the Gang of Seven, we find that the feedback controller  $C$  influences the effects of load disturbances and measurement noise. Notice that measurement noise enters the process via the feedback. In Section 13.2 it will be shown that the controller influences the sensitivity of the closed loop to process variations. The feedforward part  $F$  of the controller influences only the response to command signals.

In Chapter 10 we focused on the loop transfer function, and we found that its properties gave useful insights into the properties of a system. To make a proper assessment of a feedback system it is necessary to consider the properties of all the transfer functions (12.2) and (12.3) in the Gang of Seven (or the Gang of Four, if there is no feedforward controller), as illustrated in the following example.

**Example 12.1 The loop transfer function gives only limited insight**

Consider a process with the transfer function  $P(s) = 1/(s - a)$  controlled by a PI controller with error feedback having the transfer function  $C(s) = k(s - a)/s$ . The loop transfer function is  $L = k/s$ , and the sensitivity functions are

$$T = \frac{PC}{1 + PC} = \frac{k}{s + k}, \quad PS = \frac{P}{1 + PC} = \frac{s}{(s - a)(s + k)},$$

$$CS = \frac{C}{1 + PC} = \frac{k(s - a)}{s + k}, \quad S = \frac{1}{1 + PC} = \frac{s}{s + k}.$$

Notice that the factor  $s - a$  is canceled when computing the loop transfer function and that this factor also does not appear in the sensitivity function or the complementary sensitivity function. However, cancellation of the factor is very serious if  $a > 0$  since the transfer function  $PS$  relating load disturbances to process output is then unstable. In particular, a small disturbance  $v$  can lead to an unbounded output, which is clearly not desirable.  $\nabla$

The system in Figure 12.1 represents a special case because it is assumed that the load disturbance enters at the process input and that the measured output is the sum of the process variable and the measurement noise. Disturbances can enter in many different ways, and the sensors may have dynamics. A more abstract way to capture the general case is shown in Figure 12.2, which has only two blocks representing the process ( $\mathcal{P}$ ) and the controller ( $\mathcal{C}$ ). The process has two inputs, the control signal  $u$  and a vector of disturbances  $w$ , and two outputs, the measured signal  $y$  and a vector of signals  $z$  that is used to specify performance. The system in Figure 12.1 can be captured by choosing  $w = (r, d, n)$  and  $z = (e, u, v, \eta, \epsilon)$ . The process transfer function  $\mathcal{P}$  from  $w$  to  $z$  is a  $5 \times 3$  matrix, and the controller transfer function  $\mathcal{C}$  from  $y, r$  to  $u$  is a  $2 \times 1$  matrix; compare with Exercise 12.3.

Processes with multiple inputs and outputs can also be considered by regarding  $u$  and  $y$  as vectors. Representations at these higher levels of abstraction are useful

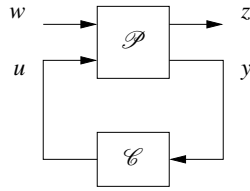
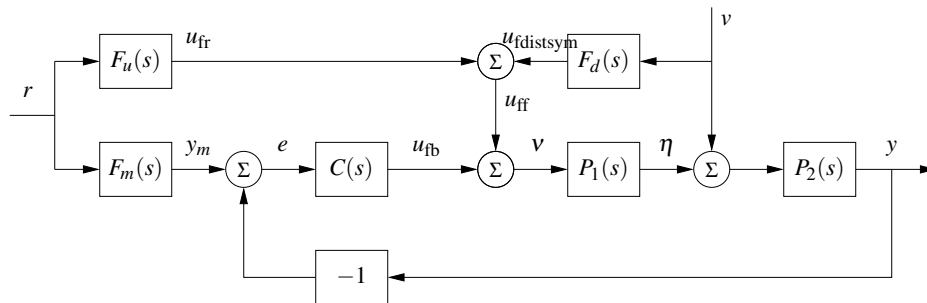

**Figure 12.2:** A more general representation of a feedback system. The process input  $u$  represents the control signal, which can be manipulated, and the process input  $w$  represents other signals that influence the process. The process output  $y$  is the vector of measured variables and  $z$  are other signals of interest.

for the development of theory because they make it possible to focus on fundamentals and to solve general problems with a wide range of applications. However, care must be exercised to maintain the coupling to the real-world control problems we intend to solve.

## 12.2 Feedforward Design

Most of our analysis and design tools up to this point have focused on the role of feedback and its effect on the dynamics of the system. Feedforward is a simple and powerful technique that complements feedback. It can be used both to improve the response to reference signals and to reduce the effect of measurable disturbances. Feedforward compensation admits perfect elimination of disturbances, but it is much more sensitive to process variations than feedback compensation. A general scheme for feedforward was discussed in Section 8.5 using Figure 8.10. A simple form of feedforward for PID controllers was discussed in Section 11.5. The controller in Figure 12.1 also has a feedforward block to improve response to command signals. An alternative version of feedforward is shown in Figure 12.3, which we will use in this section to understand some of the trade-offs between feedforward and feedback.



**Figure 12.3:** Block diagram of a system with feedforward compensation for improved response to reference signals and measured disturbances (2 DOF system). Three feedforward elements are present:  $F_m(s)$  sets the desired output value,  $F_u(s)$  generates the feedforward command  $u_{fr}$  and  $F_d(s)$  attempts to cancel disturbances.

Controllers with two degrees of freedom (feedforward and feedback) have the advantage that the response to reference signals can be designed independently of the design for disturbance attenuation and robustness. We will first consider the response to reference signals, and we will therefore initially assume that the load disturbance  $v$  is zero. Let  $F_m$  represent the ideal response of the system to reference signals. The feedforward compensator is characterized by the transfer functions  $F_u$  and  $F_m$ . When the reference is changed, the transfer function  $F_u$  generates the signal  $u_{fr}$ , which is chosen to give the desired output when applied as input to the process. Under ideal conditions the output  $y$  is then equal to  $y_m$ , the error signal is zero and there will be no feedback action. If there are disturbances or modeling errors, the signals  $y_m$  and  $y$  will differ. The feedback then attempts to bring the error to zero.

The block diagram in Figure 11.1bb for PID control is a special case of Figure 12.3. The block diagram of Figure 12.1 is equivalent to Figure 12.3 as far as responses to reference signals are concerned if  $FC = F_u + F_mC$ . The architecture Figure 12.1 has fewer blocks but it has the disadvantage that  $F$  must be changed if the controller  $C$  is changed.

To make a formal analysis, we compute the transfer function from reference input to process output:

$$G_{yr}(s) = \frac{P(CF_m + F_u)}{1 + PC} = F_m + \frac{PF_u - F_m}{1 + PC}, \quad (12.4)$$

where  $P = P_2P_1$ . The first term represents the desired transfer function. The second term can be made small in two ways. Feedforward compensation can be used to make  $PF_u - F_m$  small, or feedback compensation can be used to make  $1 + PC$  large. Perfect feedforward compensation is obtained by choosing

$$F_u = \frac{F_m}{P}. \quad (12.5)$$

Design of feedforward using transfer functions is thus a very simple task. Notice that the feedforward compensator  $F_u$  contains an inverse model of the process dynamics.

Feedback and feedforward have different properties. Feedforward action is obtained by matching two transfer functions, requiring precise knowledge of the process dynamics, while feedback attempts to make the error small by dividing it by a large quantity. For a controller having integral action, the loop gain is large for low frequencies, and it is thus sufficient to make sure that the condition for ideal feedforward holds at higher frequencies. This is easier than trying to satisfy the condition (12.5) for all frequencies.

We will now consider reduction of the effects of the load disturbance  $v$  in Figure 12.3 by feedforward control. We assume that the disturbance signal is measured and that the disturbance enters the process dynamics in a known way (captured by  $P_1$  and  $P_2$ ). The effect of the disturbance can be reduced by feeding the measured signal through a dynamical system with the transfer function  $F_d$ . Assuming that the reference  $r$  is zero, we can use block diagram algebra to find that the



transfer function from the disturbance to the process output is

$$G_{yv} = \frac{P_2(1 + P_1 F_d)}{1 + PC}, \quad (12.6)$$

where  $P = P_2 P_1$ . The effect of the disturbance can be reduced by making  $1 + F_d P_1$  small (feedforward) or by making  $1 + PC$  large (feedback). Perfect compensation is obtained by choosing

$$F_d = -P_1^{-1}, \quad (12.7)$$

requiring inversion of the transfer function  $P_1$ .

As in the case of reference tracking, disturbance attenuation can be accomplished by combining feedback and feedforward control. Since low-frequency disturbances can be eliminated by feedback, we require the use of feedforward only for high-frequency disturbances, and the transfer function  $F_d$  in equation (12.7) can then be computed using an approximation of  $P_1$  for high frequencies.

Equations (12.5) and (12.7) give analytic expressions for the feedforward compensator. To obtain a transfer function that can be implemented without difficulties we require that the feedforward compensator be stable and that it does not require differentiation. Therefore there may be constraints on possible choices of the desired response  $F_m$ , and approximations are needed if the process has zeros in the right half-plane or time delays.

### Example 12.2 Vehicle steering

A linearized model for vehicle steering was given in Example 7.4. The normalized transfer function from steering angle  $\delta$  to lateral deviation  $y$  is  $P(s) = (\gamma s + 1)/s^2$ . For a lane transfer system we would like to have a nice response without overshoot, and we therefore choose the desired response as  $F_m(s) = a^2/(s + a)^2$ , where the response speed or aggressiveness of the steering is governed by the parameter  $a$ . Equation (12.5) gives

$$F_u = \frac{F_m}{P} = \frac{a^2 s^2}{(\gamma s + 1)(s + a)^2},$$

which is a stable transfer function as long as  $\gamma > 0$ . Figure 12.4 shows the responses of the system for  $a = 0.5$ . The figure shows that a lane change is accomplished in about 10 vehicle lengths with smooth steering angles. The largest steering angle is slightly larger than 0.1 rad ( $6^\circ$ ). Using the scaled variables, the curve showing lateral deviations ( $y$  as a function of  $t$ ) can also be interpreted as the vehicle path ( $y$  as a function of  $x$ ) with the vehicle length as the length unit.  $\nabla$

A major advantage of controllers with two degrees of freedom that combine feedback and feedforward is that the control design problem can be split in two parts. The feedback controller  $C$  can be designed to give good robustness and effective disturbance attenuation, and the feedforward part can be designed independently to give the desired response to command signals.

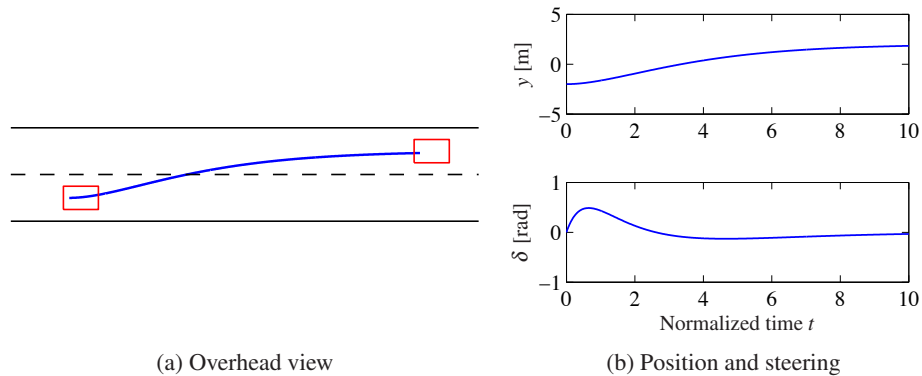

**Figure 12.4:** Feedforward control for vehicle steering. The plot on the left shows the trajectory generated by the controller for changing lanes. The plots on the right show the lateral deviation  $y$  (top) and the steering angle  $\delta$  (bottom) for a smooth lane change control using feedforward (based on the linearized model).

### 12.3 Performance Specifications

A key element of the control design process is how we specify the desired performance of the system. It is also important for users to understand performance specifications so that they know what to ask for and how to test a system. Specifications are often given in terms of robustness to process variations and responses to reference signals and disturbances. They can be given in terms of both time and frequency responses. Specifications for the step response to reference signals were given in Figure 6.9 in Section 6.3 and in Section 7.3. Robustness specifications based on frequency domain concepts were provided in Section 10.3 and will be considered further in Chapter 13. The specifications discussed previously were based on the loop transfer function. Since we found in Section 12.1 that a single transfer function did not always characterize the properties of the closed loop completely, we will give a more complete discussion of specifications in this section, based on the full Gang of Seven.

The transfer function gives a good characterization of the linear behavior of a system. To provide specifications it is desirable to capture the characteristic properties of a system with a few parameters. Common features of step responses are overshoot, rise time and settling time, as shown in Figure 6.9. Common features of frequency responses are resonant peak, peak frequency, gain crossover frequency and bandwidth. A *resonant peak* is a maximum of the gain, and the peak frequency is the corresponding frequency. The *gain crossover frequency* is the frequency where the open loop gain is equal one. The *bandwidth* is defined as the frequency range where the closed loop gain is  $1/\sqrt{2}$  of the low-frequency gain (low-pass), mid-frequency gain (band-pass) or high-frequency gain (high-pass). The crossover frequency and the bandwidth are only well defined if the curves are monotone, if this is not the case the bandwidth is typically defined as the lowest frequency.

There are interesting relations between specifications in the time and frequency

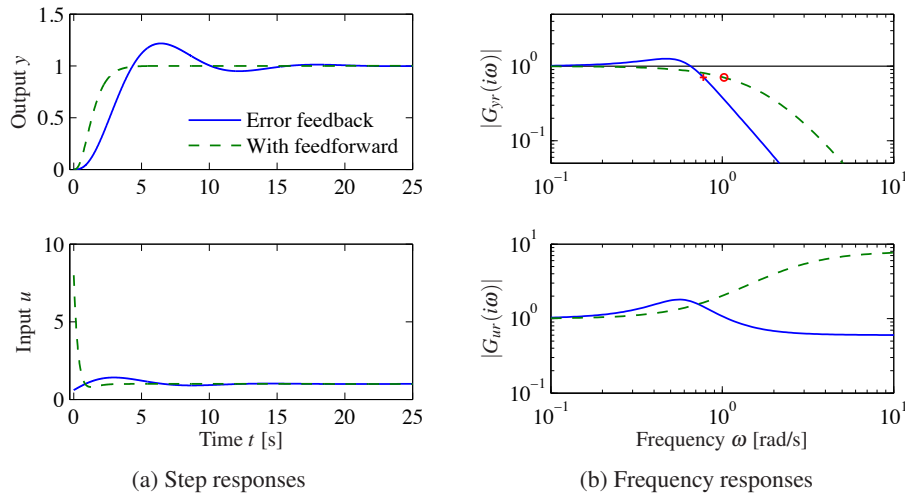

**Figure 12.5:** Reference signal responses. The responses in process output  $y$  and control signal  $u$  to a unit step in the reference signal  $r$  are shown in (a), and the gain curves of  $G_{yr}$  and  $G_{ur}$  are shown in (b). Results with PI control with error feedback are shown by solid lines, and the dashed lines show results for a controller with a feedforward compensator.

domains. Roughly speaking, the behavior of time responses for short times is related to the behavior of frequency responses at high frequencies, and vice versa. The precise relations are given by the Laplace transform.

### Response to Reference Signals

Consider the basic feedback loop in Figure 12.1. The response to reference signals is described by the transfer functions  $G_{yr} = PCF/(1 + PC)$  and  $G_{ur} = CF/(1 + PC)$  ( $F = 1$  for systems with error feedback). Notice that it is useful to consider both the response of the output and that of the control signal. In particular, the control signal response allows us to judge the magnitude and rate of the control signal required to obtain the output response.

#### Example 12.3 Third-order system

Consider a process with the transfer function  $P(s) = (s + 1)^{-3}$  and a PI controller with error feedback having the gains  $k_p = 0.6$  and  $k_i = 0.5$ . The responses are illustrated in Figure 12.5. The solid lines show results for a proportional-integral (PI) controller with error feedback. The dashed lines show results for a controller with feedforward designed to give the transfer function  $G_{yr} = (0.5s + 1)^{-3}$ . Looking at the time responses, we find that the controller with feedforward gives a faster response with no overshoot. However, much larger control signals are required to obtain the fast response. The largest value of the control signal is 8, compared to 1.2 for the regular PI controller. The controller with feedforward has a larger bandwidth (marked with  $\circ$ ) and no resonant peak. The transfer function  $G_{ur}$  also has higher gain at high frequencies.  $\nabla$

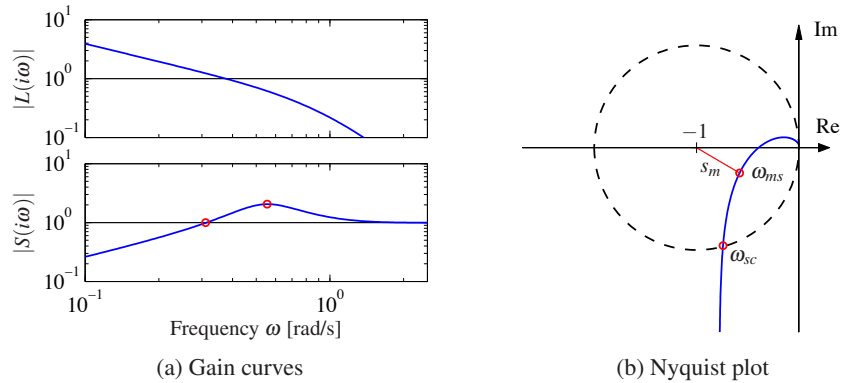

**Figure 12.6:** Graphical interpretation of the sensitivity function. Gain curves of the loop transfer function and the sensitivity function (a) can be used to calculate the properties of the sensitivity function through the relation  $S = 1/(1 + L)$ . The sensitivity crossover frequency  $\omega_{sc}$  and the frequency  $\omega_{ms}$  where the sensitivity has its largest value are indicated in the sensitivity plot. The Nyquist plot (b) shows the same information in a different form. All points inside the dashed circle have sensitivities greater than 1.

### Response to Load Disturbances and Measurement Noise

A simple criterion for disturbance attenuation is to compare the output of the closed loop system in Figure 12.1 with the output of the corresponding open loop system obtained by setting  $C = 0$ . If we let the disturbances for the open and closed loop systems be identical, the output of the closed loop system is then obtained simply by passing the open loop output through a system with the transfer function  $S$ . The sensitivity function tells how the variations in the output are influenced by feedback (Exercise 12.7). Disturbances with frequencies such that  $|S(i\omega)| < 1$  are attenuated, but disturbances with frequencies such that  $|S(i\omega)| > 1$  are amplified by feedback. The maximum sensitivity  $M_s$ , which occurs at the frequency  $\omega_{ms}$ , is thus a measure of the largest amplification of the disturbances. The maximum magnitude of  $1/(1 + L)$  corresponds to the minimum of  $|1 + L|$ , which is precisely the stability margin  $s_m$  defined in Section 10.3, so that  $M_s = 1/s_m$ . The maximum sensitivity is therefore also a robustness measure.

If the sensitivity function is known, the potential improvements by feedback can be evaluated simply by recording a typical output and filtering it through the sensitivity function. A plot of the gain curve of the sensitivity function is a good way to make an assessment of the disturbance attenuation. Since the sensitivity function depends only on the loop transfer function, its properties can also be visualized graphically using the Nyquist plot of the loop transfer function. This is illustrated in Figure 12.6. The complex number  $1 + L(i\omega)$  can be represented as the vector from the point  $-1$  to the point  $L(i\omega)$  on the Nyquist curve. The sensitivity is thus less than 1 for all points outside a circle with radius 1 and center at  $-1$ . Disturbances with frequencies in this range are attenuated by the feedback.

The transfer function  $G_{yv}$  from load disturbance  $v$  to process output  $y$  for the

system in Figure 12.1 is

$$G_{yv} = \frac{P}{1+PC} = PS = \frac{T}{C}. \quad (12.8)$$

Since load disturbances typically have low frequencies, it is natural to focus on the behavior of the transfer function at low frequencies. Consider a system with  $P(0) \neq 0$  and a controller with integral action with integral gain  $k_i$ . The controller transfer function goes to infinity as  $k_i/s$  for small  $s$  and we have the following approximation:

$$G_{yv} = \frac{T}{C} \approx \frac{1}{C} \approx \frac{s}{k_i}, \quad (12.9)$$

The process transfer function  $P$  typically goes to zero for large  $s$  as does a well designed controller  $C$ . The loop transfer function  $PC$  then also goes to zero and the sensitivity function  $S$  goes to 1 for large  $s$ . We then have the approximation  $G_{yv} \approx P$  for large  $s$ .

Measurement noise, which typically has high frequencies, generates rapid variations in the control variable that are detrimental because they cause wear in many actuators and can even saturate an actuator. It is thus important to keep variations in the control signal due to measurement noise at reasonable levels—a typical requirement is that the variations are only a fraction of the span of the control signal. The variations can be influenced by filtering and by proper design of the high-frequency properties of the controller.

The effects of measurement noise are captured by the transfer function from the measurement noise to the control signal,

$$-G_{uw} = \frac{C}{1+PC} = CS = \frac{T}{P}. \quad (12.10)$$

For controllers with integral action the complementary sensitivity function is close to 1 for low frequencies ( $\omega < \omega_{gc}$ ), and  $G_{uw}$  can be approximated by  $-1/P$ . The sensitivity function is close to 1 for high frequencies ( $\omega > \omega_{gc}$ ), and  $G_{uw}$  can be approximated by  $-C$ .

#### Example 12.4 Third-order system

Consider a process with the transfer function  $P(s) = (s+1)^{-3}$  and a proportional-integral-derivative (PID) controller with gains  $k_p = 0.6$ ,  $k_i = 0.5$  and  $k_d = 2.0$ . We augment the controller using a second-order noise filter with damping ratio  $1/\sqrt{2}$  and  $T_f = 0.1$ . The controller transfer function then becomes

$$C(s) = \frac{k_d s^2 + k_p s + k_i}{s(s^2 T_f^2 / 2 + s T_f + 1)}.$$

The closed loop system responses are illustrated in Figure 12.7. The closed loop response of the output to a step in the load disturbance in the top part of Figure 12.7a has a peak of 0.28 at time  $t = 2.73$  s. The frequency response in Figure 12.7a shows that the gain has a maximum of 0.58 at  $\omega = 0.7$  rad/s.

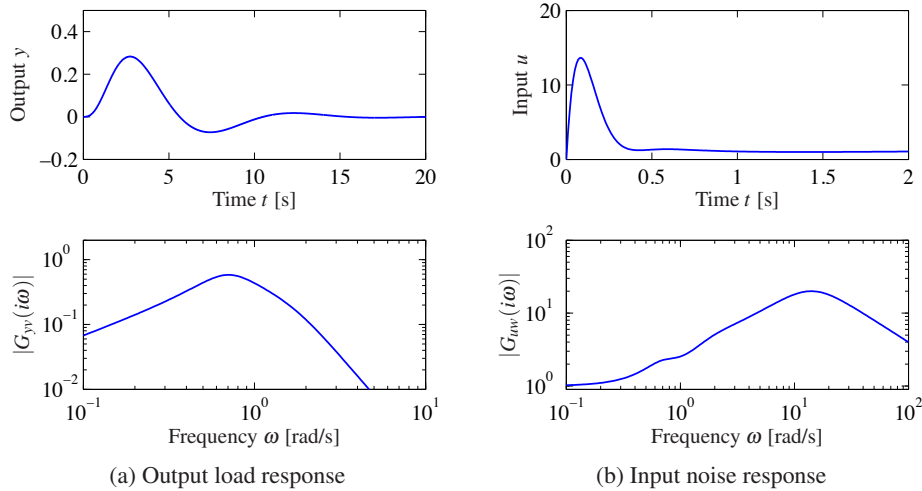

**Figure 12.7:** Closed loop disturbance responses. The time and frequency responses of process output  $y$  to load disturbance  $v$  are shown in (a) and the responses of control signal  $u$  to measurement noise  $w$  are shown in (b).

The closed loop response of the control signal to a step in measurement noise is shown in Figure 12.7b. The high-frequency roll-off of the transfer function  $G_{uw}(i\omega)$  is due to filtering; without it the gain curve in Figure 12.7b would continue to rise after 20 rad/s. The step response has a peak of 13 at  $t = 0.08$  s. The frequency response has its peak 20 at  $\omega = 14$  rad/s. Notice that the peak occurs at a frequency far above the peak of the response to load disturbances and far above the gain crossover frequency  $\omega_{gc} = 0.78$  rad/s. An approximation derived in Exercise 12.9 gives  $\max |CS(i\omega)| \approx k_d/T_f = 20$ , which occurs at  $\omega = \sqrt{2}/T_d = 14.1$  rad/s.  $\nabla$

## 12.4 Feedback Design via Loop Shaping

One advantage of the Nyquist stability theorem is that it is based on the loop transfer function, which is related to the controller transfer function through  $L = PC$ . It is thus easy to see how the controller influences the loop transfer function. To make an unstable system stable we simply have to bend the Nyquist curve away from the critical point.

This simple idea is the basis of several different design methods collectively called *loop shaping*. These methods are based on choosing a compensator that gives a loop transfer function with a desired shape. One possibility is to determine a loop transfer function that gives a closed loop system with the desired properties and to compute the controller as  $C = L/P$ . This approach may lead to controllers of high order and there are limitations if the process transfer function has poles and zeros in the right half plane as will be discussed in Section 12.6. Another is

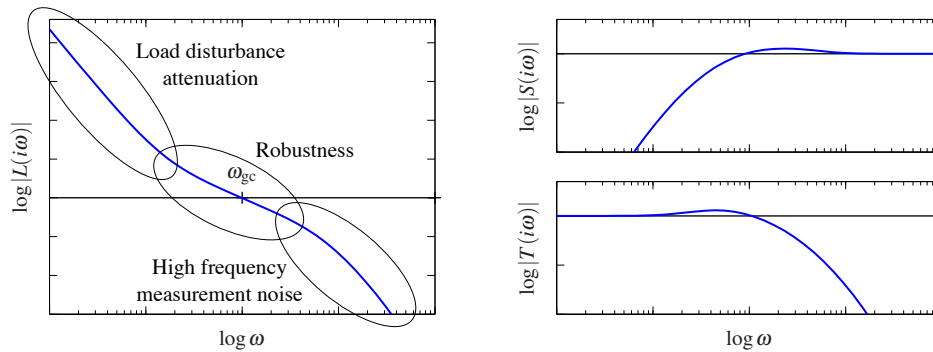

**Figure 12.8:** Gain curve and sensitivity functions for a typical loop transfer function. The plot on the left shows the gain curve and the plots on the right show the sensitivity function and complementary sensitivity function. The crossover frequency  $\omega_{gc}$  determines the attenuation of load disturbances, bandwidth and response time of the closed loop system. The slope  $n_{gc}$  determines the robustness of the closed loop systems, see (12.11). At low frequencies, a large magnitude of  $L$  provides good load disturbance rejection and reference tracking, while at high frequencies a small loop gain avoids injecting too much measurement noise.

to start with the process transfer function, change its gain and then add poles and zeros until the desired shape is obtained. In this section we will explore different loop-shaping methods for control law design.

### Design Considerations

We will first discuss a suitable shape for the loop transfer function that gives good performance and good stability margins. Figure 12.8 shows a typical loop transfer function. Good robustness requires good stability margins (or good gain and phase margins), which imposes requirements on the loop transfer function around the crossover frequencies  $\omega_{pc}$  and  $\omega_{gc}$ . The gain of  $L$  at low frequencies must be large in order to have good tracking of command signals and good attenuation of low-frequency disturbances. Since  $S = 1/(1+L)$ , it follows that for frequencies where  $|L| > 101$  disturbances will be attenuated by a factor of 100 and the tracking error is less than 1%. It is therefore desirable to have a large crossover frequency and a steep (negative) slope of the gain curve. The choice of gain crossover frequency  $\omega_{gc}$  is a compromise among attenuation of load disturbances, injection of measurement noise and robustness. The controller gain at low frequencies can be increased by a controller with integral action, which is also called *lag compensation*. To avoid injecting too much measurement noise into the system, the controller transfer function should have low gain at high frequencies, a property called *high-frequency roll-off*.

Bode's relations (see Section 10.4) impose restrictions on the shape of the loop transfer function. Equation (10.8) implies that the slope of the gain curve at gain crossover cannot be too steep. If the gain curve has a constant slope, we have the

following relation between slope  $n_{gc}$  and phase margin  $\phi_m$ :

$$n_{gc} = -2 + \frac{2\phi_m}{\pi}. \quad (12.11)$$

This formula is a reasonable approximation when the gain curve does not deviate too much from a straight line. It follows from equation (12.11) that the phase margins  $30^\circ$ ,  $45^\circ$  and  $60^\circ$  correspond to the slopes  $-5/3$ ,  $-3/2$  and  $-4/3$ .

Loop shaping is a trial-and-error procedure. We typically start with a Bode plot of the process transfer function. We then attempt to shape the loop transfer function by changing the controller gain and adding poles and zeros to the controller transfer function. Different performance specifications are evaluated for each controller as we attempt to balance many different requirements by adjusting controller parameters and complexity. Loop shaping is straightforward to apply to single-input, single-output systems. It can also be applied to systems with one input and many outputs by closing the loops one at a time. The only limitation for minimum phase systems is that large phase leads and high controller gains may be required to obtain closed loop systems with a fast response. Many specific procedures are available: they all require experience, but they also give good insight into the conflicting requirements. There are fundamental limitations to what can be achieved for systems that are not minimum phase; they will be discussed in the next section.

### Lead and Lag Compensation

A simple way to do loop shaping is to start with the transfer function of the process and add simple compensators with the transfer function

$$C(s) = k \frac{s+a}{s+b}, \quad a > 0, b > 0. \quad (12.12)$$

The compensator is called a *lead compensator* if  $a < b$ , and a *lag compensator* if  $a > b$ . The PI controller is a special case of a lag compensator with  $b = 0$ , and the ideal PD controller is a special case of a lead compensator with  $a = 0$ . Bode plots of lead and lag compensators are shown in Figure 12.9. Lag compensation, which increases the gain at low frequencies, is typically used to improve tracking performance and disturbance attenuation at low frequencies. Compensators that are tailored to specific disturbances can be also designed, as shown in Exercise 12.10. Lead compensation is typically used to improve phase margin. The following examples give illustrations.

#### Example 12.5 Atomic force microscope in tapping mode

A simple model of the dynamics of the vertical motion of an atomic force microscope in tapping mode was given in Exercise 10.2. The transfer function for the system dynamics is

$$P(s) = \frac{a(1 - e^{-s\tau})}{s\tau(s+a)},$$



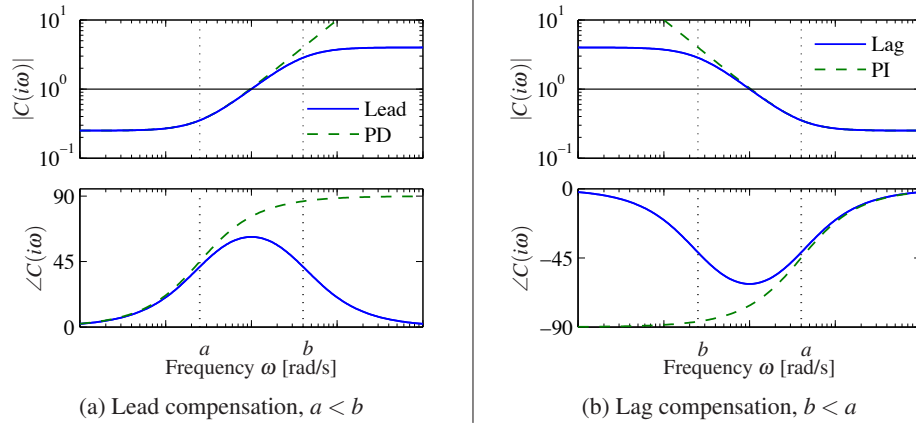
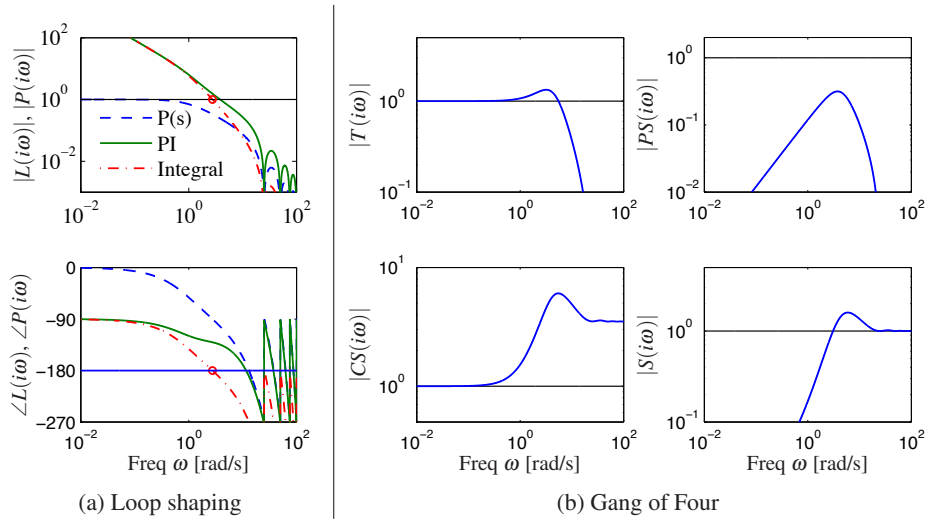

**Figure 12.9:** Frequency response for lead and lag compensators  $C(s) = k(s + a)/(s + b)$ . Lead compensation (a) occurs when  $a < b$  and provides phase lead between  $\omega = a$  and  $\omega = b$ . Lag compensation (b) corresponds to  $a > b$  and provides low-frequency gain. PI control is a special case of lag compensation and PD control is a special case of lead compensation. PI/PD frequency responses are shown by dashed curves.

and the parameters  $a = \zeta \omega_0$ ,  $\tau = 2\pi n/\omega_0$  are explained in XXX. The gain has been normalized to 1. A Bode plot of this transfer function for the parameters  $a = 1$  and  $\tau = 0.25$  is shown in dashed curves in Figure 12.10a. To improve the attenuation of load disturbances we increase the low-frequency gain by introducing an integral controller. The loop transfer function then becomes  $L = k_i P(s)/s$ , and we start by adjusting the gain  $k_i$  so that the closed loop system is marginally stable, giving  $k_i = 8.3$ . The Bode plot is shown by the dash-dotted line in Figure 12.10a, where the critical point is indicated by  $\circ$ . Notice the increase of the gain at low frequencies. To obtain a reasonable phase margin we introduce proportional action and we increase the proportional gain  $k_p$  gradually until reasonable values of the sensitivities are obtained. The value  $k_p = 3.5$  gives maximum sensitivity  $M_s = 1.6$  and maximum complementary sensitivity  $M_t = 1.3$ . The loop transfer function is shown in solid lines in Figure 12.10a. Notice the significant increase of the phase margin compared with the purely integral controller (dash-dotted line).

To evaluate the design we also compute the gain curves of the transfer functions in the Gang of Four. They are shown in Figure 12.10b. The peaks of the sensitivity curves are reasonable, and the plot of  $PS$  shows that the largest value of  $PS$  is 0.3, which implies that the load disturbances are well attenuated. The plot of  $CS$  shows that the largest noise gain  $|C(i\omega)S(i\omega)|$  is 6. The controller has a gain  $k_p = 3.5$  at high frequencies, and hence we may consider adding high-frequency roll-off to make  $CS$  smaller at high frequencies.  $\nabla$

A common problem in the design of feedback systems is that the phase margin is too small, and phase *lead* must then be added to the system. If we set  $a < b$  in equation (12.12), we add phase lead in the frequency range between the pole/zero pair (and extending approximately  $10\times$  in frequency in each direction). By approx-



**Figure 12.10:** Loop-shaping design of a controller for an atomic force microscope in tapping mode. (a) Bode plots of the process (dashed), the loop transfer function for an integral controller with critical gain (dash-dotted) and a PI controller (solid) adjusted to give reasonable robustness. (b) Gain curves for the Gang of Four for the system.

privately choosing the location of this phase lead, we can provide additional phase margin at the gain crossover frequency.

Because the phase of a transfer function is related to the slope of the magnitude, increasing the phase requires increasing the gain of the loop transfer function over the frequency range in which the lead compensation is applied. In Exercise 12.14 it is shown that the gain increases exponentially with the amount of phase lead. We can also think of the lead compensator as changing the slope of the transfer function and thus shaping the loop transfer function in the crossover region (although it can be applied elsewhere as well).

### Example 12.6 Roll control for a vectored thrust aircraft

Consider the control of the roll of a vectored thrust aircraft such as the one illustrated in Figure 12.11. Following Exercise 9.10, we model the system with a second-order transfer function of the form

$$P(s) = \frac{r}{Js^2},$$

with the parameters given in Figure 12.11b. We take as our performance specification that we would like less than 1% error in steady state for and less than 10% tracking error up to 10 rad/s.

The open loop transfer function from  $F_1$  to  $\theta$  is shown in Figure 12.12a. To achieve our performance specification, we would like to have a gain of at least 10 at a frequency of 10 rad/s, requiring the gain crossover frequency to be at a higher frequency. We see from the loop shape that in order to achieve the desired performance we cannot simply increase the gain since this would give a very low phase

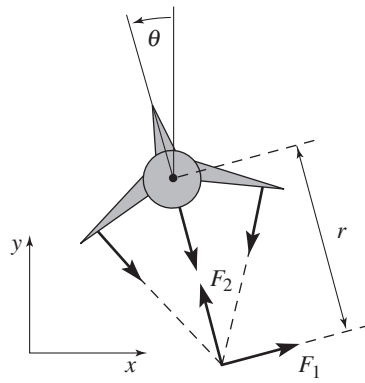

(a) Simplified model

Symbol	Description	Value
$m$	Vehicle mass	4.0 kg
$J$	Vehicle inertia, $\varphi_3$ axis	0.0475 kg m <sup>2</sup>
$r$	Force moment arm	25.0 cm
$c$	Damping coefficient	0.05 kg m/s
$g$	Gravitational constant	9.8 m/s <sup>2</sup>

(b) Parameter values

**Figure 12.11:** Roll control of a vectored thrust aircraft. (a) The roll angle  $\theta$  is controlled by applying maneuvering thrusters, resulting in a moment generated by  $F_1$ . (b) The table lists the parameter values for a laboratory version of the system.

margin. Instead, we must increase the phase at the desired crossover frequency.

To accomplish this, we use a lead compensator (12.12) with  $a = 2$  and  $b = 50$ . We then set the gain of the system to provide a large loop gain up to the desired bandwidth, as shown in Figure 12.12b. We see that this system has a gain of greater than 10 at all frequencies up to 10 rad/s and that it has more than  $60^\circ$  of phase margin.  $\nabla$

The action of a lead compensator is essentially the same as that of the derivative portion of a PID controller. As described in Section 11.5, we often use a filter for the derivative action of a PID controller to limit the high-frequency gain. This same effect is present in a lead compensator through the pole at  $s = b$ .

Equation (12.12) is a first-order compensator and can provide up to  $90^\circ$  of phase lead. Larger phase lead can be obtained by using a higher-order lead compensator (Exercise 12.14):

$$C(s) = k \frac{(s+a)^n}{(s+b)^n}, \quad a < b.$$

## 12.5 The Root-Locus Method

In the design methods like pole placement in Sections 2.2, 2.3 and 8.3, we designed controllers that give desired closed loop poles. The controllers were sufficiently complex so that all closed loop poles could be specified. The complexity of the controller is thus related to the complexity of the process. In a practice we may have to use a simple controller for a complex process and it is then not possible to find a controller that gives all closed poles their desired values. It is interesting to explore what can be done with a controller having restricted complexity as was the case for loop shaping in Section 12.4. The simplest case with only one selectable

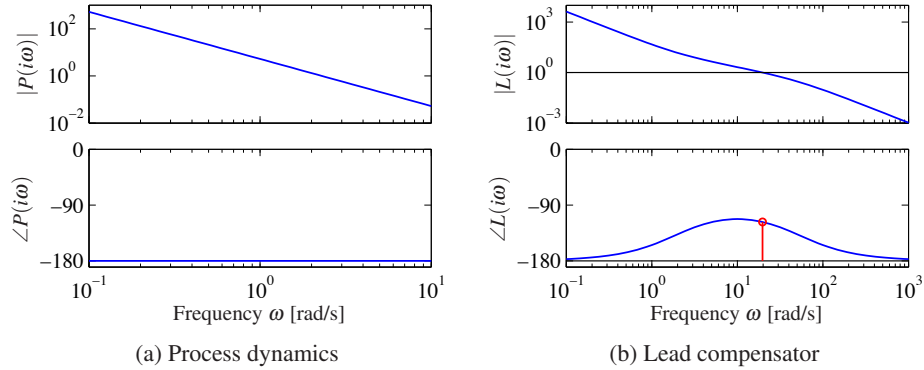

**Figure 12.12:** Control design for a vectored thrust aircraft using lead compensation. The Bode plot for the open loop process  $P$  is shown in (a) and for the loop transfer function  $L = PC$  using a lead compensator  $C$  in (b). Note the phase lead in the crossover region near  $\omega = 100$  rad/s.

controller parameter can be investigated with the *root locus method*. The *root locus* is a graph of the roots of the characteristic equation as a function of the parameter. The method gives insight into the effects of the controller parameter. It is straight forward to obtain the root locus by finding the roots of the closed-loop characteristic polynomial for different values of the parameter. There are also good computer tools for generating the root locus. Of greater interest is that the general shape of the root locus can be obtained with very little effort. The root locus also gives considerable insight.

### Proportional Control

To illustrate the root locus method we consider a process with the transfer function

$$P(s) = \frac{b(s)}{a(s)} = \frac{b_0 s^m + b_1 s^{m-1} + \cdots + b_m}{s^n + a_1 s^{n-1} + \cdots + a_n} = b_0 \frac{(s - z_1)(s - z_2) \cdots (s - z_m)}{(s - p_1)(s - p_2) \cdots (s - p_n)}.$$

The polynomial  $a(s)$  has degree  $n$  and the polynomial  $b(s)$  has degree  $m$ . We assume that the integer  $n_{pe} = n - m$ , which is called the *pole excess* is positive or zero. The controller is assumed to be a proportional controller with the transfer function  $C(s) = k$ . We will explore the poles of the closed loop system when the gain  $k$  of the proportional controller ranges from 0 to  $\infty$ .

The closed loop characteristic polynomial is

$$a_{cl}(s) = a(s) + kb(s), \quad (12.13)$$

and the closed loop poles are the roots of  $a_{cl}(s)$ . The root-locus is a graph of the roots of  $a_{cl}(s)$  as the gain  $k$  is varies from 0 to  $\infty$ . Since the polynomial  $a_{cl}(s)$  has degree  $n$  the plot will have  $n$  branches.

The branches start from the open loop poles. When the gain is  $k$  zero we have  $a_{cl}(s) = a(s)$  and the closed loop poles are equal to the open loop poles. When

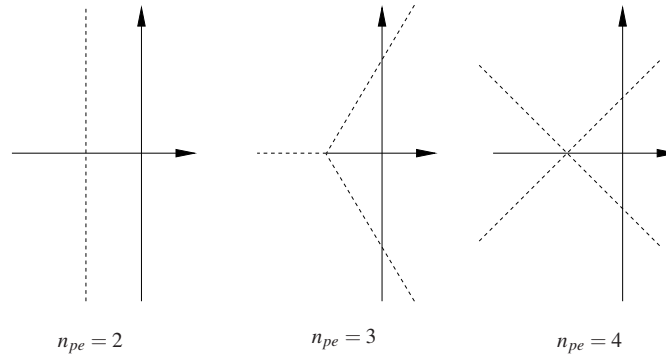

**Figure 12.13:** Asymptotes of of root locus for systems with pole excess  $n_{pe} = 2, 3$  and  $4$ . There are  $n_{pe}$  asymptotes radiate from the point given by equation 12.15, and the angles between the asymptotes are  $2\pi/n_{pe}$ .

there are open loop poles with multiplicity  $n^*$  the characteristic equation can be written as

$$(s - p_l)^{n^*} \tilde{a}(s) + kb(s) \approx (s - p_l)^{n^*} \tilde{a}(p_l) + kb(p_l) = 0.$$

For small values of  $k$  the roots are  $s = p_l + \sqrt[n^*]{-kb(p_l)/\tilde{a}(p_l)}$ . The root locus has a star pattern with  $n^*$  branches emanating from the open loop pole  $s = p_l$ . The angle between two neighboring branches is  $2\pi/n^*$ .

To explore what happens for large gain we approximate the characteristic equation (12.13) for large  $s$  and  $k$ , hence

$$a_{cl}(s) = b(s) \left( \frac{a(s)}{b(s)} + k \right) \approx b(s) \left( \frac{s^{n_{pe}}}{b_0} + k \right). \quad (12.14)$$

For large  $k$  the closed loop poles are approximately the roots of  $b(s)$  and  $\sqrt[n_{pe}]{-b_0 k}$ . A better approximation of (12.14) is

$$s = s_0 + \sqrt[n_{pe}]{-kb_0}, \quad s_0 = \frac{1}{n_{pe}} \left( \sum_{k=1}^n p_k - \sum_{k=1}^m z_k \right), \quad (12.15)$$

see Exercise 12.11. The asymptotes are thus  $n_{pe}$  lines that radiate from  $s = s_0$ , the center of mass of poles and zeros. When  $b_0 k > 0$  the lines have the angles  $(\pi + 2l\pi)/n_{pe}, l = 1, \dots, n_{pe}$  with the real line. Figure 12.13 shows the asymptotes of the root locus for large gain for different values of the pole excess  $n_{pe}$ .

Summarizing we find that the root locus thus has  $n$  branches that start at the loop poles and end either at the open loop poles or at infinity. The branches that ends at infinity have the star-patterned asymptotes given by (12.15). An immediate consequence is that open loop systems with right half plane zeros or a pole excess larger than 2 will always be unstable for sufficiently large gains.

There are simple rules for sketching root loci. Let it suffice to mention a few of them. The root locus has locally the symmetric star pattern at points where

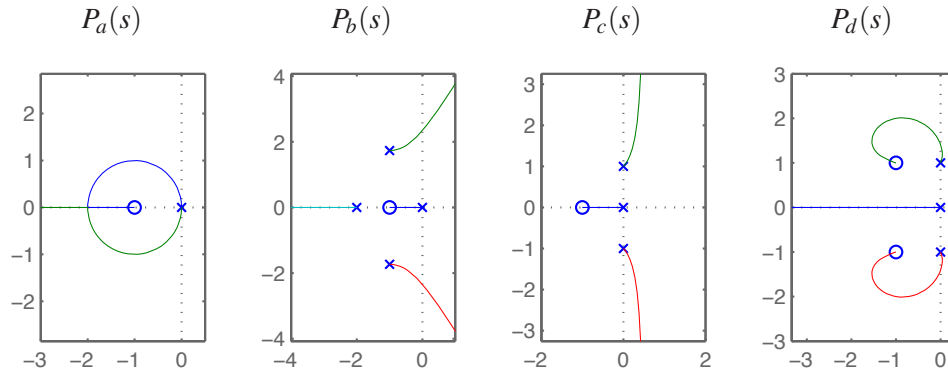

**Figure 12.14:** Examples of root loci for processes with the transfer functions  $P_a(s)$ ,  $P_b(s)$ ,  $P_c(s)$  and  $P_d(s)$  given by equation (12.16).

there are multiple roots; the number of branches depend on the multiplicity of the roots. For systems with  $kb_0 > 0$  the root locus has segments on the real line where there are odd numbers of real poles and zeros to the right of the segment, see Exercise 12.12. It is also straight forward to find direction where a branch of the root locus leaves a pole, see Exercise 12.13.

Figure 12.14 show root loci for systems with  $k > 0$  and the transfer functions.

$$\begin{aligned}
 P_a(s) &= k \frac{s+1}{s^2}, & P_b(s) &= k \frac{s+1}{s(s+2)(s^2+2s+4)} \\
 P_c(s) &= k \frac{s+2}{s(s^2+1)}, & P_d(s) &= k \frac{s^2+2s+2}{s(s^2+1)}.
 \end{aligned} \tag{12.16}$$

The locus of  $P_a(s)$  in Figure 12.14a starts with two roots at the origin and the pattern locally has the star configuration with  $n^* = 2$ . As the gain increases the locus bends because of the attraction of the zero. In this particular case the locus is actually a circle around the zero  $s = -1$ . Two roots meet at the real axis, and there is the typical star pattern. One root goes towards the zero and the other one goes to infinity along the negative real axis as the gain  $k$  increases. The root locus has the segment  $(-\infty, -1]$  on the real axis. The locus in Figure 12.14b start at the open loop poles  $s = -2, 0$  and  $-1 \pm i\sqrt{3}$ . The pole excess is  $n_{pe} = 3$  and the asymptotes which originate from  $s_0 = -1$ , have the corresponding pattern. The locus in Figure 12.14c has vertical asymptotes since  $n_{pe} = 2$ , see Figure 12.13. The asymptotes originate from  $s_0 = 0.5$ . The root locus has the segment  $[-1, 0]$  on the real line. The locus in Figure 12.14d has three branches, one is the segment  $(-\infty, 0]$  on the real line the other segment originate in the complex open loop poles and end at the open loop zeros.

The root locus is useful for qualitative arguments. For example, it follows from Figure Figure 12.13 that the closed loop system will always be unstable for sufficiently large gains if the pole excess is larger than  $n_{pe} = 2$  or if the process transfer

function has zeros in the right half plane.

The root locus can also be used for design. Consider for example the system in Figure 12.14c which can represent PI control of a system with the transfer function

$$P(s) = \frac{1}{s^2 + 1}, \quad C(s) = k \frac{s+2}{s}$$

The root locus in Figure 12.14c shows that the system is unstable for all values of the controller gain and we can immediately conclude that the process cannot be stabilized with a PI controller. To obtain a stable closed loop system we can attempt to choose a PID controller with zeros to the left of the undamped poles, for example

$$C(s) = k \frac{s^2 + 2s + 2}{s}.$$

The root locus obtained with this controller is shown in Figure 12.14d.

We have illustrated the root locus with a closed loop system with a proportional controller where the parameter is the gain. The root locus also be used to find the effects of other parameters as was illustrated in Example 5.15.

## 12.6 Fundamental Limitations

Although loop shaping gives us a great deal of flexibility in designing the closed loop response of a system, there are certain fundamental limits on what can be achieved. We consider here some of the primary performance limitations that can occur because of difficult dynamics; additional limitations related to robustness are considered in the next chapter.

### Right Half-Plane Poles and Zeros and Time Delays

There are linear systems that are inherently difficult to control. The limitations are related to poles and zeros in the right half-plane and time delays. To explore the limitations caused by poles and zeros in the right half-plane we factor the process transfer function as

$$P(s) = P_{mp}(s)P_{ap}(s), \quad (12.17)$$

where  $P_{mp}$  is the minimum phase part and  $P_{ap}$  is the nonminimum phase part, we require that  $P_{mp}$  has all its zeros in the open left half plane. The factorization is normalized so that  $|P_{ap}(i\omega)| = 1$ , and the sign is chosen so that  $P_{ap}$  has negative phase. The transfer function  $P_{ap}$  is called an *all-pass system* because it has unit gain for all frequencies. We have for example

$$P(s) = \frac{s-2}{(s+1)(s-1)} = \frac{s+2}{(s+1)^2} \frac{(s-2)(s+1)}{(s+2)(s-1)}. \quad (12.18)$$

The transfer function  $P_{ap}$  does not influence the gain curve in the Bode plot but it does influence the phase curve. Requiring that the phase margin be  $\phi_m$ , we get

$$\arg L(i\omega_{gc}) = \arg P_{ap}(i\omega_{gc}) + \arg P_{mp}(i\omega_{gc}) + \arg C(i\omega_{gc}) \geq -\pi + \phi_m, \quad (12.19)$$

where  $C$  is the controller transfer function. Let  $n_{gc}$  be the slope of the gain curve at the crossover frequency. Since  $|P_{ap}(i\omega)| = 1$ , it follows that

$$n_{gc} = \left. \frac{d \log |L(i\omega)|}{d \log \omega} \right|_{\omega=\omega_{gc}} = \left. \frac{d \log |P_{mp}(i\omega)C(i\omega)|}{d \log \omega} \right|_{\omega=\omega_{gc}}.$$

If the slope  $n_{gc}$  is negative, it has to be larger than  $-2$  for the closed loop system to be stable. It follows from Bode's relations, equation (10.8), that

$$\arg P_{mp}(i\omega) + \arg C(i\omega) \approx n_{gc} \frac{\pi}{2}.$$

Combining this with equation (12.19) gives the following inequality for the allowable phase lag of the all-pass part at the gain crossover frequency:

$$-\arg P_{ap}(i\omega_{gc}) \leq \pi - \varphi_m + n_{gc} \frac{\pi}{2} =: \varphi_l. \quad (12.20)$$

In addition we must require that the encirclement condition of the Nyquist theorem is satisfied.

The condition (12.20), which we call the *gain crossover frequency inequality*, shows that the gain crossover frequency must be chosen so that the phase lag of the nonminimum phase component is not too large. For systems with high robustness requirements we may choose a phase margin of  $60^\circ$  ( $\varphi_m = \pi/3$ ) and a slope  $n_{gc} = -1$ , which gives an admissible phase lag  $\varphi_l = \pi/6 = 0.52$  rad ( $30^\circ$ ). For systems where we can accept a lower robustness we may choose a phase margin of  $45^\circ$  ( $\varphi_m = \pi/4$ ) and the slope  $n_{gc} = -1/2$ , which gives an admissible phase lag  $\varphi_l = \pi/2 = 1.57$  rad ( $90^\circ$ ).

The crossover frequency inequality (12.20), shows that nonminimum phase components impose severe restrictions on possible crossover frequencies. It also means that there are systems that cannot be controlled with sufficient stability margins. We illustrate the limitations in a number of commonly encountered situations.

### Example 12.7 Zero in the right half-plane

The nonminimum phase part of the process transfer function for a system with a right half-plane zero is

$$P_{ap}(s) = \frac{z-s}{z+s},$$

where  $z > 0$ . Notice that we have  $z-s$  in the numerator instead of  $s-z$  to satisfy the condition that  $P_{ap}$  should have negative phase. The phase lag of the nonminimum phase part is

$$-\arg P_{ap}(i\omega) = 2 \arctan \frac{\omega}{z}.$$

Since the phase lag of  $P_{ap}$  increases with frequency, the inequality (12.20) gives the following bound on the crossover frequency:

$$\omega_{gc} < z \tan(\varphi_l/2). \quad (12.21)$$



With  $\varphi_l = \pi/3$  we get  $\omega_{gc} < 0.6z$ . Slow right half-plane zeros ( $z$  small) therefore give tighter restrictions on possible gain crossover frequencies than fast right half-plane zeros.  $\nabla$

Time delays also impose limitations similar to those given by zeros in the right half-plane. We can understand this intuitively from the Padé approximation

$$e^{-s\tau} \approx \frac{1 - 0.5s\tau}{1 + 0.5s\tau} = \frac{2/\tau - s}{2/\tau + s}.$$

A long time delay is thus approximately equivalent to a slow right half-plane zero  $z = 2/\tau$ .

### Example 12.8 Pole in the right half-plane

The nonminimum phase part of the transfer function for a system with a pole in the right half-plane is

$$P_{ap}(s) = \frac{s+p}{s-p},$$

where  $p > 0$ . The sign of  $P_{ap}$  is dictated by the condition that it should have negative phase. The phase lag of the nonminimum phase part is

$$-\arg P_{ap}(i\omega) = 2 \arctan \frac{p}{\omega},$$

and the crossover frequency inequality becomes

$$\omega_{gc} > \frac{p}{\tan(\varphi_l/2)}. \quad (12.22)$$

Right half-plane poles thus require that the closed loop system have a sufficiently high gain crossover frequency, a consequence is that the actuators must be fast. With  $\varphi_l = \pi/3$  we get  $\omega_{gc} > 1.7p$ . Fast right half-plane poles ( $p$  large) therefore require a larger gain crossover frequency than slower right half-plane poles. The control of unstable systems imposes minimum bandwidth requirements for process actuators and sensors.  $\nabla$

We will now consider systems with a right half-plane zero  $z$  and a right half-plane pole  $p$ . If  $p = z$ , there will be cancellation of an unstable system mode and the system cannot be stabilized. A cancellation of an unstable pole means that the system has an unstable mode that is not reachable and observable, see Section 8.5. We can therefore expect that the system is difficult to control if the right half-plane pole and zero are close. A straightforward way to use the crossover frequency inequality is to plot the phase of the nonminimum phase factor  $P_{ap}$  of the process transfer function. Such a plot, which can be incorporated in an ordinary Bode plot, will immediately show the permissible gain crossover frequencies. An illustration is given in Figure 12.15, which shows the phase of the transfer functions for systems with a right half-plane pole/zero pair and systems with a right half-plane pole and a time delay. The transfer functions of the systems are

$$P_{ap}(s) = \frac{(bs-1)(s+1)}{(bs+1)(s-1)}, \quad P_{ap}(s) = \frac{s+1}{s-1} e^{-\tau s} \quad (12.23)$$

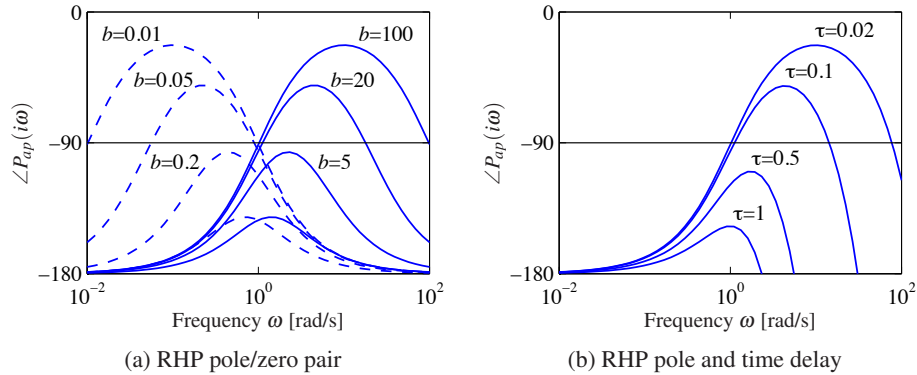

**Figure 12.15:** Example limitations due to the gain crossover frequency inequality. The figures show the phase lag of the all-pass factor  $P_{ap}$  as a function of frequency for the systems (12.23). Since the phase lag of  $P_{ap}$  at the gain crossover frequency cannot be too large, it is necessary to choose the gain crossover frequency properly. All systems have a right half-plane pole at  $s = 1$ . The system in (a) has zeros at  $s = 2, 5, 20$  and  $100$  (solid lines) and at  $s = 0.5, 0.2, 0.05$  and  $0.01$  (dashed lines). The system in (b) has time delays  $\tau = 0.02, 0.1, 0.5$  and  $1$ .

To illustrate the limitations we will introduce numerical values. If we require that the phase lag  $\phi_l$  of the nonminimum phase factor be less than  $90^\circ$ , we must require that the ratio  $z/p$  be larger than  $6$  or smaller than  $1/6$  for systems with right half-plane poles and zeros and that the product  $p\tau$  be less than  $0.3$  for systems with a time delay and a right half-plane pole. Notice the symmetry in the problem for  $z > p$  and  $z < p$ : in either case the zeros and the poles must be sufficiently far apart (Exercise 12.15). Also notice that possible values of the gain crossover frequency  $\omega_{gc}$  are quite restricted.

Using the theory of functions of complex variables, it can be shown that for systems with a right half-plane pole  $p$  and a right half-plane zero  $z$  (or a time delay  $\tau$ ), any stabilizing controller gives sensitivity functions with the property

$$\sup_{\omega} |S(i\omega)| \geq \frac{p+z}{|p-z|}, \quad \sup_{\omega} |T(i\omega)| \geq e^{p\tau}. \quad (12.24)$$

This result is proven in Exercise 12.16.

As the examples above show, right half-plane poles and zeros significantly limit the achievable performance of a system, hence one would like to avoid these whenever possible. The poles of a system depend on the intrinsic dynamics of the system and are given by the eigenvalues of the dynamics matrix  $A$  of a linear system. Sensors and actuators have no effect on the poles; the only way to change poles is to redesign the system. Notice that this does not imply that unstable systems should be avoided. Unstable system may actually have advantages; one example is high-performance supersonic aircraft.

The zeros of a system depend on how the sensors and actuators are coupled to the states. The zeros depend on all the matrices  $A, B, C$  and  $D$  in a linear system.

The zeros can thus be influenced by moving the sensors and actuators or by adding sensors and actuators.

### Example 12.9 Balance system

As an example of a system with both right half-plane poles and zeros, consider the balance system with zero damping shown in Example 3.1, whose dynamics are given by

$$H_{\theta F} = \frac{ml}{-(M_t J_t - m^2 l^2)s^2 + mglM_t},$$

$$H_{pF} = \frac{-J_t s^2 + mgl}{s^2(-(M_t J_t - m^2 l^2)s^2 + mglM_t)}.$$

Assume that we want to stabilize the pendulum by using the cart position as the measured signal. The transfer function from the input force  $F$  to the cart position  $p$  has poles  $\{0, 0, \pm\sqrt{mglM_t/(M_t J_t - m^2 l^2)}\}$  and zeros  $\{\pm\sqrt{mgl/J_t}\}$ . Using the parameters in Example 7.7, the right half-plane pole is at  $p = 2.68$  and the zero is at  $z = 2.09$ . Equation (12.24) then gives  $|S(i\omega)| \geq 8$ , which shows that it is not possible to control the system robustly.

The right half-plane zero of the system can be eliminated by changing the output of the system. For example, if we choose the output to correspond to a position at a distance  $r$  along the pendulum, we have  $y = p - r \sin \theta$  and the transfer function for the linearized output becomes

$$H_{y,F} = H_{pF} - rH_{\theta F} = \frac{(mlr - J_t)s^2 + mgl}{s^2(-(M_t J_t - m^2 l^2)s^2 + mglM_t)}.$$

If we choose  $r$  sufficiently large, then  $mlr - J_t > 0$  and we eliminate the right half-plane zero, obtaining instead two pure imaginary zeros. The gain crossover frequency inequality is then based just on the right half-plane pole (Example 12.8). If our admissible phase lag for the nonminimum phase part is  $\varphi_l = 45^\circ$ , then our gain crossover must satisfy

$$\omega_{gc} > \frac{p}{\tan(\varphi_l/2)} = 6.48 \text{ rad/s}.$$

If the actuators have sufficiently high bandwidth, e.g., a factor of 10 above  $\omega_{gc}$  or roughly 10 Hz, then we can provide robust tracking up to this frequency.  $\nabla$

### Bode's Integral Formula

In addition to providing adequate phase margin for robust stability, a typical control design will have to satisfy performance conditions on the sensitivity functions (Gang of Four). In particular, the sensitivity function  $S = 1/(1+PC)$  represents the disturbance attenuation and also relates the tracking error  $e$  to the reference signal  $r$ : we usually want the sensitivity to be small over the range of frequencies where we want small tracking error and good disturbance attenuation. A basic problem is to investigate if  $S$  can be made small over a large frequency range. We will start by investigating an example.

**Example 12.10 System that admits small sensitivities**

Consider a closed loop system consisting of a first-order process and a proportional controller. Let the loop transfer function be

$$L(s) = PC = \frac{k}{s+1},$$

where parameter  $k$  is the controller gain. The sensitivity function is

$$S(s) = \frac{s+1}{s+1+k}$$

and we have

$$|S(i\omega)| = \sqrt{\frac{1+\omega^2}{1+2k+k^2+\omega^2}}.$$

This implies that  $|S(i\omega)| < 1$  for all finite frequencies and that the sensitivity can be made arbitrarily small for any finite frequency by making  $k$  sufficiently large.  $\nabla$

The system in Example 12.10 is unfortunately an exception. The key feature of the system is that the Nyquist curve of the process is completely contained in the right half-plane. Such systems are called *passive*, their transfer functions are *positive real* and their physics is associated with energy dissipation. For typical control systems there are severe constraints on the sensitivity function. The following theorem, due to Bode, provides insights into the limits of performance under feedback.

**Theorem 12.1** (Bode's integral formula). *Let  $S(s)$  be the sensitivity function of an internally stable system with loop transfer function  $L(s)$ . Assume that the loop transfer function  $L(s)$  is such that  $sL(s)$  goes to zero as  $s \rightarrow \infty$ , then the sensitivity function satisfies the following integral:*

$$\int_0^\infty \log |S(i\omega)| d\omega = \int_0^\infty \log \frac{1}{|1+L(i\omega)|} d\omega = \pi \sum p_k. \quad (12.25)$$

where the sum is over the right half plane poles  $p_k$  of  $L(s)$ .

Equation (12.25) implies that there are fundamental limitations to what can be achieved by control and that control design can be viewed as a redistribution of disturbance attenuation over different frequencies. In particular, this equation shows that if the sensitivity function is made smaller for some frequencies, it must increase at other frequencies so that the integral of  $\log |S(i\omega)|$  remains constant. This means that if disturbance attenuation is improved in one frequency range, it will be worse in another, a property sometime referred to as the *waterbed effect*. It also follows that systems with open loop poles in the right half-plane have larger overall sensitivity than stable systems.

Equation (12.25) can be regarded as a *conservation law*: if the loop transfer function has no poles in the right half-plane, the equation simplifies to

$$\int_0^\infty \log |S(i\omega)| d\omega = 0.$$

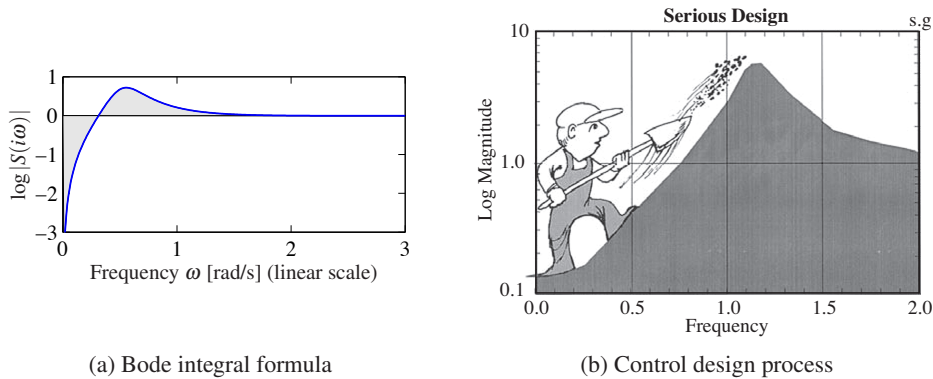

**Figure 12.16:** Interpretation of the *waterbed effect*. The function  $\log |S(i\omega)|$  is plotted versus  $\omega$  in linear scales in (a). According to Bode's integral formula (12.25), the area of  $\log |S(i\omega)|$  above zero must be equal to the area below zero. Gunter Stein's interpretation of design as a trade-off of sensitivities at different frequencies is shown in (b) (from [Ste03]).

This formula can be given a nice geometric interpretation as illustrated in Figure 12.16, which shows  $\log |S(i\omega)|$  as a function of  $\omega$ . The area over the horizontal axis must be equal to the area under the axis when the frequency is plotted on a *linear* scale. Thus if we wish to make the sensitivity smaller up to some frequency  $\omega_{sc}$ , we must balance this by increased sensitivity above  $\omega_{sc}$ . Control system design can be viewed as trading the disturbance attenuation at some frequencies for disturbance amplification at other frequencies. Notice that the system in Example 12.10 violates the condition that  $\lim_{s \rightarrow \infty} sL(s) = 0$  and hence the integral formula does not apply.

There is a result analogous to equation (12.25) for the complementary sensitivity function:

$$\int_0^{\infty} \frac{\log |T(i\omega)|}{\omega^2} d\omega = \pi \sum \frac{1}{z_i}, \quad (12.26)$$

where the summation is over all right half-plane zeros. Notice that slow right half-plane zeros are worse than fast ones and that fast right half-plane poles are worse than slow ones.

### Example 12.11 X-29 aircraft

As an example of the application of Bode's integral formula, we present an analysis of the control system for the X-29 aircraft (see Figure 12.17a), which has an unusual configuration of aerodynamic surfaces that are designed to enhance its maneuverability. This analysis was originally carried out by Gunter Stein in his article "Respect the Unstable" [Ste03], which is also the source of the quote at the beginning of this chapter.

To analyze this system, we make use of a small set of parameters that describe the key properties of the system. The X-29 has longitudinal dynamics that are very similar to inverted pendulum dynamics (Exercise 9.3) and, in particular, have a pair of poles at approximately  $p = \pm 6$  and a zero at  $z = 26$ . The actuators that



(a) X-29 aircraft

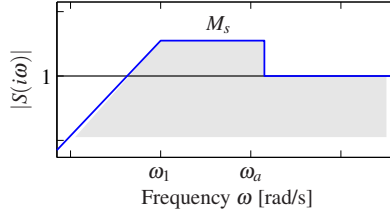

(b) Sensitivity analysis

**Figure 12.17:** X-29 flight control system. The aircraft makes use of forward swept wings and a set of canards on the fuselage to achieve high maneuverability (a). The desired sensitivity for the closed loop system is shown in (b). We seek to use our control authority to shape the sensitivity curve so that we have low sensitivity (good performance) up to frequency  $\omega_1$  by creating higher sensitivity up to our actuator bandwidth  $\omega_a$ .

stabilize the pitch have a bandwidth of  $\omega_a = 40$  rad/s and the desired bandwidth of the pitch control loop is  $\omega_1 = 3$  rad/s. Since the ratio of the zero to the pole is only 4.3, we may expect that it may be difficult to achieve the specifications.

To evaluate the achievable performance, we search for a control law such that the sensitivity function is small up to the desired bandwidth and not greater than  $M_s$  beyond that frequency. Because of the Bode integral formula, we know that  $M_s$  must be greater than 1 at high frequencies to balance the small sensitivity at low frequency. We thus ask if we can find a controller that has the shape shown in Figure 12.17b with the smallest value of  $M_s$ . Note that the sensitivity above the frequency  $\omega_a$  is not specified since we have no actuator authority at that frequency. However, assuming that the process dynamics fall off at high frequency, the sensitivity at high frequency will approach 1. Thus, we desire to design a closed loop system that has low sensitivity at frequencies below  $\omega_1$  and sensitivity that is not too large between  $\omega_1$  and  $\omega_a$ .

From Bode's integral formula, we know that whatever controller we choose, equation (12.25) must hold. We will assume that the sensitivity function is given by

$$|S(i\omega)| = \begin{cases} \frac{\omega M_s}{\omega_1} & \omega \leq \omega_1 \\ M_s & \omega_1 \leq \omega \leq \omega_a, \end{cases}$$

corresponding to Figure 12.17b. If we further assume that  $|L(s)| \leq \delta/\omega^2$  for frequencies larger than the actuator bandwidth, Bode's integral becomes

$$\begin{aligned} \int_0^\infty \log |S(i\omega)| d\omega &= \int_0^{\omega_a} \log |S(i\omega)| d\omega \\ &= \int_0^{\omega_1} \log \frac{\omega M_s}{\omega_1} d\omega + (\omega_a - \omega_1) \log M_s = \pi p. \end{aligned}$$

Evaluation of the integral gives  $-\omega_1 + \omega_a \log M_s = \pi p$  or

$$M_s = e^{(\pi p + \omega_1)/\omega_a}.$$

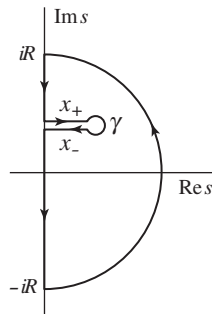

**Figure 12.18:** Contour used to prove Bode's theorem. For each right half-plane pole we create a path from the imaginary axis that encircles the pole as shown. To avoid clutter we have shown only one of the paths that enclose one right half-plane.

This formula tells us what the achievable value of  $M_s$  will be for the given control specifications. In particular, using  $p = 6$ ,  $\omega_1 = 3$  and  $\omega_a = 40$  rad/s, we find that  $M_s = 1.75$ , which means that in the range of frequencies between  $\omega_1$  and  $\omega_a$ , disturbances at the input to the process dynamics (such as wind) will be amplified by a factor of 1.75 in terms of their effect on the aircraft.

Another way to view these results is to compute the phase margin that corresponds to the given level of sensitivity. Since the peak sensitivity normally occurs at or near the crossover frequency, we can compute the phase margin corresponding to  $M_s = 1.75$ . As shown in Exercise 12.17, the maximum achievable phase margin for this system is approximately  $35^\circ$ , which is below the usual design limit of  $45^\circ$  in aerospace systems. The zero at  $s = 26$  limits the maximum gain crossover that can be achieved.  $\nabla$

### Derivation of Bode's Formula



We now derive Bode's integral formula (Theorem 12.1). This is a technical section that requires some knowledge of the theory of complex variables, in particular contour integration. Assume that the loop transfer function has distinct poles at  $s = p_k$  in the right half-plane and that  $L(s)$  goes to zero faster than  $1/s$  for large values of  $s$ .

Consider the integral of the logarithm of the sensitivity function  $S(s) = 1/(1 + L(s))$  over the contour shown in Figure 12.18. The contour encloses the right half-plane except for the points  $s = p_k$  where the loop transfer function  $L(s) = P(s)C(s)$  has poles and the sensitivity function  $S(s)$  has zeros. The direction of the contour is counterclockwise.

The integral of the log of the sensitivity function around this contour is given by

$$\begin{aligned} \int_{\Gamma} \log(S(s)) ds &= \int_{iR}^{-iR} \log(S(s)) ds + \int_R \log(S(s)) ds + \sum_k \int_{\gamma} \log(S(s)) ds \\ &= I_1 + I_2 + I_3 = 0, \end{aligned}$$

where  $R$  is a large semicircle on the right and  $\gamma_k$  is the contour starting on the imaginary axis at  $s = \text{Im } p_k$  and a small circle enclosing the pole  $p_k$ . The integral is zero because the function  $\log S(s)$  is analytic inside the contour. We have

$$I_1 = -i \int_{-R}^R \log(S(i\omega)) d\omega = -2i \int_0^R \log(|S(i\omega)|) d\omega$$

because the real part of  $\log S(i\omega)$  is an even function and the imaginary part is an odd function. Furthermore we have

$$I_2 = \int_R \log(S(s)) ds = - \int_R \log(1 + L(s)) ds \approx - \int_R L(s) ds.$$

Since  $L(s)$  goes to zero faster than  $1/s$  for large  $s$ , the integral goes to zero when the radius of the circle goes to infinity.

Next we consider the integral  $I_3$ . For this purpose we split the contour into three parts  $X_+$ ,  $\gamma$  and  $X_-$ , as indicated in Figure 12.18. We can then write the integral as

$$I_3 = \int_{X_+} \log S(s) ds + \int_{\gamma} \log S(s) ds + \int_{X_-} \log S(s) ds.$$

The contour  $\gamma$  is a small circle with radius  $r$  around the pole  $p_k$ . The magnitude of the integrand is of the order  $\log r$ , and the length of the path is  $2\pi r$ . The integral thus goes to zero as the radius  $r$  goes to zero. Since  $S(s) \approx k/(s - p_k)$  close to the pole, the argument of  $S(s)$  decreases by  $2\pi$  as the contour encircles the pole. On the contours  $X_+$  and  $X_-$  we therefore have

$$|S_{X_+}| = |S_{X_-}|, \quad \arg S_{X_-} = \arg S_{X_+} - 2\pi.$$

Hence

$$\log(S_{X_+}) - \log(S_{X_-}) = 2\pi i,$$

and we get

$$\int_{X_+} \log S(s) ds + \int_{X_-} \log S(s) ds = 2\pi i \text{Re } p_k.$$

Repeating the argument for all poles  $p_k$  in the right half plane, letting the small circles go to zero gives

$$I_1 + I_2 + I_3 = -2i \int_0^\infty \log |S(i\omega)| d\omega + i \sum_k 2\pi \text{Re } p_k = 0.$$

Since complex poles appear as complex conjugate pairs,  $\sum_k \text{Re } p_k = \sum_k p_k$ , which gives Bode's formula (12.25).

## 12.7 Design Example

In this section we present a detailed example that illustrates the main design techniques described in this chapter.

### Example 12.12 Lateral control of a vectored thrust aircraft

The problem of controlling the motion of a vertical takeoff and landing (VTOL)



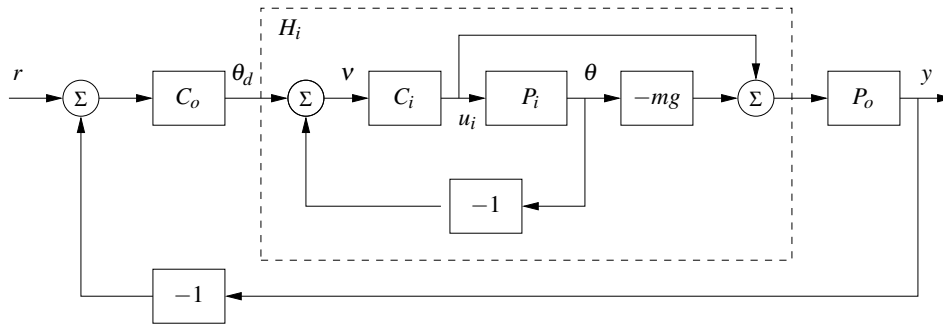

**Figure 12.19:** Inner/outer control design for a vectored thrust aircraft. The inner loop  $H_i$  controls the roll angle of the aircraft using the vectored thrust. The outer loop controller  $C_o$  commands the roll angle to regulate the lateral position. The process dynamics are decomposed into inner loop ( $P_i$ ) and outer loop ( $P_o$ ) dynamics, which combine to form the full dynamics for the aircraft.

aircraft was introduced in Example 3.11 and in Example 12.6, where we designed a controller for the roll dynamics. We now wish to control the position of the aircraft, a problem that requires stabilization of the attitude. The system thus has two control loops.

To control the lateral dynamics of the vectored thrust aircraft, we make use of a “inner/outer” loop design methodology, as illustrated in Figure 12.19. This diagram shows the process dynamics and controller divided into two components: an *inner loop* consisting of the roll dynamics and control and an *outer loop* consisting of the lateral position dynamics and controller. This decomposition follows the block diagram representation of the dynamics given in Exercise 9.10.

The approach that we take is to design a controller  $C_i$  for the inner loop so that the resulting closed loop system  $H_i$  assures that the roll angle  $\theta$  follows its reference  $\theta_r$  fast and accurately. We then design a controller for the lateral position  $y$  that uses the approximation that we can directly control the roll angle as an input  $\theta$  to the dynamics controlling the position. Under the assumption that the dynamics of the roll controller are fast relative to the desired bandwidth of the lateral position control, we can then combine the inner and outer loop controllers to get a single controller for the entire system. As a performance specification for the entire system, we would like to have zero steady-state error in the lateral position, a bandwidth of approximately 1 rad/s and a phase margin of  $45^\circ$ .

For the inner loop, we choose our design specification to provide the outer loop with accurate and fast control of the roll. The inner loop dynamics are given by

$$P_i = H_{\theta u_1} = \frac{r}{J_S^2}.$$

We choose the desired bandwidth to be 10 rad/s (10 times that of the outer loop) and the low-frequency error to be no more than 5%. This specification is satisfied

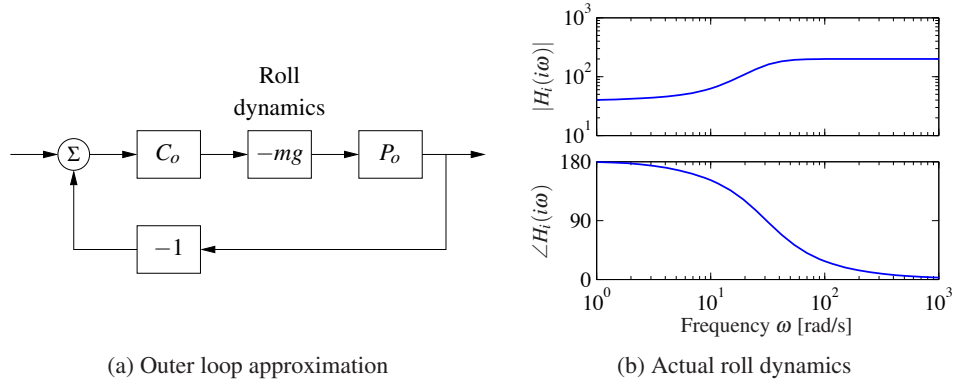

**Figure 12.20:** Outer loop control design for a vectored thrust aircraft. (a) The outer loop approximates the roll dynamics as a state gain  $-mg$ . (b) The Bode plot for the roll dynamics, indicating that this approximation is accurate up to approximately 10 rad/s.

using the lead compensator of Example 12.6 designed previously, so we choose

$$C_i(s) = k \frac{s+a}{s+b}, \quad a = 2, \quad b = 50, \quad k = 1.$$

The closed loop dynamics for the system satisfy

$$H_i = \frac{C_i}{1 + C_i P_i} - mg \frac{C_i P_i}{1 + C_i P_i} = \frac{C_i(1 - mg P_i)}{1 + C_i P_i}.$$

A plot of the magnitude of this transfer function is shown in Figure 12.20, and we see that  $H_i \approx -mg = -39.2$  is a good approximation up to 10 rad/s.

To design the outer loop controller, we assume the inner loop roll control is perfect, so that we can take  $\theta_d$  as the input to our lateral dynamics. Following the diagram shown in Exercise 9.10, the outer loop dynamics can be written as

$$P(s) = H_i(0)P_o(s) = \frac{H_i(0)}{ms^2 + cs},$$

where we replace  $H_i(s)$  with  $H_i(0)$  to reflect our approximation that the inner loop will eventually track our commanded input. Of course, this approximation may not be valid, and so we must verify this when we complete our design.

Our control goal is now to design a controller that gives zero steady-state error in  $y$  for a step input and has a bandwidth of 1 rad/s. The outer loop process dynamics are given by a double integrator, and we can again use a simple lead compensator to satisfy the specifications. We also choose the design such that the loop transfer function for the outer loop has  $|L_o| < 0.1$  for  $\omega > 10$  rad/s, so that the  $H_i$  high frequency dynamics can be neglected. We choose the controller to be of the form

$$C_o(s) = -k_o \frac{s+a_o}{s+b_o},$$

with the negative sign to cancel the negative sign in the process dynamics. To find

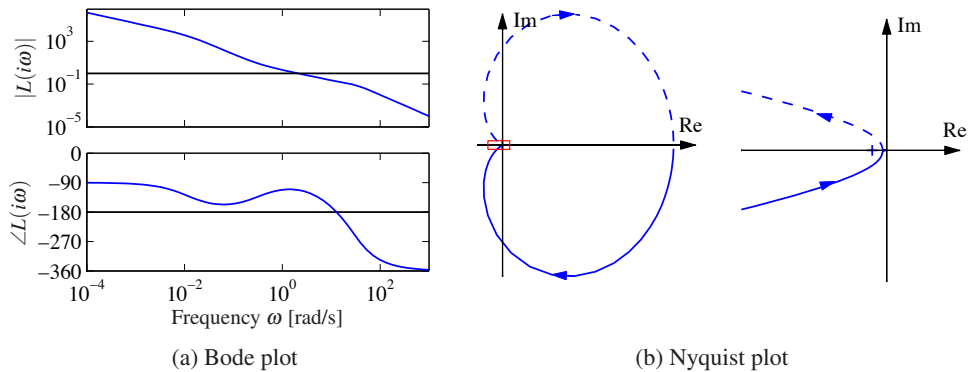

**Figure 12.21:** Inner/outer loop controller for a vectored thrust aircraft. Bode plot (a) and Nyquist plot (b) for the loop transfer function cut at  $\theta_d$ , for the complete system. The system has a phase margin of  $68^\circ$  and a gain margin of 6.2.

the location of the poles, we note that the phase lead flattens out at approximately  $b_o/10$ . We desire phase lead at crossover, and we desire the crossover at  $\omega_{gc} = 1$  rad/s, so this gives  $b_o = 10$ . To ensure that we have adequate phase lead, we must choose  $a_o$  such that  $b_o/10 < 10a_o < b_o$ , which implies that  $a_o$  should be between 0.1 and 1. We choose  $a_o = 0.3$ . Finally, we need to set the gain of the system such that at crossover the loop gain has magnitude 1. A simple calculation shows that  $k_o = 2$  satisfies this objective. Thus, the final outer loop controller becomes

$$C_o(s) = -2 \frac{s + 0.3}{s + 10}.$$

Finally, we can combine the inner and outer loop controllers and verify that the system has the desired closed loop performance. The Bode and Nyquist plots corresponding to Figure 12.19 with inner and outer loop controllers are shown in Figure 12.21, and we see that the specifications are satisfied. In addition, we show the Gang of Four in Figure 12.22, and we see that the transfer functions between all inputs and outputs are reasonable. The sensitivity to load disturbances  $PS$  is large at low frequency because the controller does not have integral action.

The approach of splitting the dynamics into an inner and an outer loop is common in many control applications and can lead to simpler designs for complex systems. Indeed, for the aircraft dynamics studied in this example, it is very challenging to directly design a controller from the lateral position  $y$  to the input  $u_1$ . The use of the additional measurement of  $\theta$  greatly simplifies the design because it can be broken up into simpler pieces.  $\nabla$

## 12.8 Further Reading

Design by loop shaping was a key element in the early development of control, and systematic design methods were developed; see James, Nichols and Phillips [JNP47],

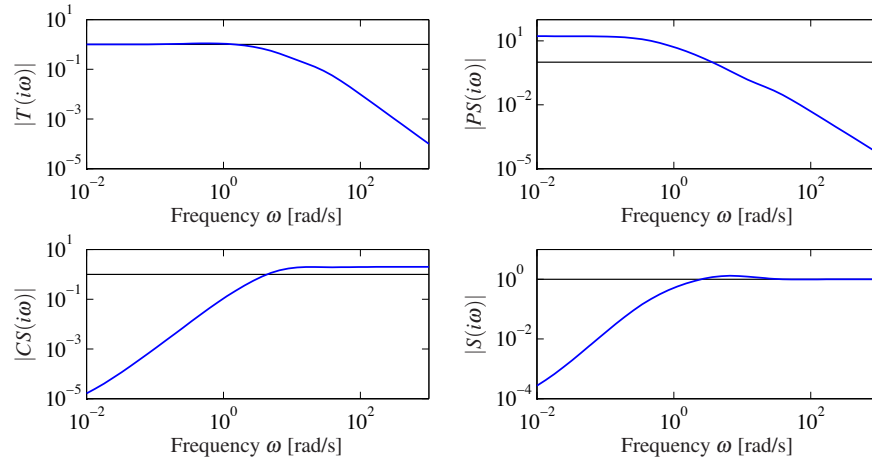

**Figure 12.22:** Gang of Four for vectored thrust aircraft system.

Chestnut and Mayer [CM51], Truxal [Tru55] and Thaler [Tha89]. Loop shaping is also treated in standard textbooks such as Franklin, Powell and Emami-Naeini [FPEN05], Dorf and Bishop [DB04], Kuo and Golnaraghi [KG02] and Ogata [Oga01]. Systems with two degrees of freedom were developed by Horowitz [Hor63], who also discussed the limitations of poles and zeros in the right half-plane. Fundamental results on limitations are given in Bode [Bod45]; more recent presentations are found in Goodwin, Graebe and Salgado [GGS01]. The treatment in Section 12.6 is based on [Åst00]. Much of the early work was based on the loop transfer function; the importance of the sensitivity functions appeared in connection with the development in the 1980s that resulted in  $H_\infty$  design methods. A compact presentation is given in the texts by Doyle, Francis and Tannenbaum [DFT92] and Zhou, Doyle and Glover [ZDG96]. Loop shaping was integrated with the robust control theory in McFarlane and Glover [MG90] and Vinnicombe [Vin01]. Comprehensive treatments of control system design are given in Maciejowski [Mac89] and Goodwin, Graebe and Salgado [GGS01].

## Exercises

**12.1** Consider the system in Figure 12.1. Give all signal pairs that are related by the transfer functions  $1/(1+PC)$ ,  $P/(1+PC)$ ,  $C/(1+PC)$  and  $PC/(1+PC)$ .

**12.2** Consider the system in Example 12.1. Choose the parameters  $a = -1$  and compute the time and frequency responses for all the transfer functions in the Gang of Four for controllers with  $k = 0.2$  and  $k = 5$ .

**12.3** (Equivalence of Figures 12.1 and 12.2) Consider the system in Figure 12.1 and let the outputs of interest be  $z = (\eta, v)$  and the major disturbances be  $w = (n, d)$ . Show that the system can be represented by Figure 12.2 and give the matrix

transfer functions  $\mathcal{P}$  and  $\mathcal{C}$ . Verify that the elements of the closed loop transfer function  $H_{zw}$  are the Gang of Four.

**12.4** Consider the spring–mass system given by (3.16), which has the transfer function

$$P(s) = \frac{1}{ms^2 + cs + k}.$$

Design a feedforward compensator that gives a response with critical damping ( $\zeta = 1$ ).

**12.5** (Sensitivity of feedback and feedforward) Consider the system in Figure 12.1 and let  $G_{yr}$  be the transfer function relating the measured signal  $y$  to the reference  $r$ . Show that the sensitivities of  $G_{yr}$  with respect to the feedforward and feedback transfer functions  $F$  and  $C$  are given by  $dG_{yr}/dF = CP/(1 + PC)$  and  $dG_{yr}/dC = FP/(1 + PC)^2 = G_{yr}S/C$ .

**12.6** (Equivalence of controllers with two degrees of freedom) Show that the systems in Figures 12.1 and 12.3 give the same responses to command signals if  $F_m C + F_u = CF$ .

**12.7** (Disturbance attenuation) Consider the feedback system shown in Figure 12.1. Assume that the reference signal is constant. Let  $y_{ol}$  be the measured output when there is no feedback and  $y_{cl}$  be the output with feedback. Show that  $Y_{cl}(s) = S(s)Y_{ol}(s)$ , where  $S$  is the sensitivity function.

**12.8** (Disturbance reduction through feedback) Consider a problem in which an output variable has been measured to estimate the potential for disturbance attenuation by feedback. Suppose an analysis shows that it is possible to design a closed loop system with the sensitivity function

$$S(s) = \frac{s}{s^2 + s + 1}.$$

Estimate the possible disturbance reduction when the measured disturbance is

$$y(t) = 5 \sin(0.1t) + 3 \sin(0.17t) + 0.5 \cos(0.9t) + 0.1t.$$

**12.9** Show that the effect of high frequency measurement noise on the control signal for the system in Example 12.4 can be approximated by

$$CS \approx C = \frac{k_d s}{(sT_f)^2/2 + sT_f + 1},$$

and that the largest value of  $|CS(i\omega)|$  is  $k_d/T_f$  which occurs for  $\omega = \sqrt{2}/T_f$ .

**12.10** (Attenuation of low-frequency sinusoidal disturbances) Integral action eliminates constant disturbances and reduces low-frequency disturbances because the controller gain is infinite at zero frequency. A similar idea can be used to reduce the effects of sinusoidal disturbances of known frequency  $\omega_0$  by using the controller

$$C(s) = k_p + \frac{k_s s}{s^2 + 2\zeta\omega_0 s + \omega_0^2}.$$

This controller has the gain  $C_s(i\omega_0) = k_p + k_s/(2\zeta)$  for the frequency  $\omega_0$ , which can be large by choosing a small value of  $\zeta$ . Assume that the process has the transfer function  $P(s) = 1/s$ . Determine the Bode plot of the loop transfer function and simulate the system. Compare the results with PI control.

**12.11** (Asymptotes of root locus) Consider proportional control of a system with the transfer function

$$P(s) = \frac{b(s)}{a(s)} = \frac{b_0s^m + b_1s^{m-1} + \cdots + b_m}{s^n + a_1s^{n-1} + \cdots + a_n} = b_0 \frac{(s - z_1)(s - z_2) \cdots (s - z_m)}{(s - p_1)(s - p_2) \cdots (s - p_n)}.$$

Show that the root locus has asymptotes that are straight line that emerge from the point

$$s_0 = \frac{1}{n_e} \left( \sum_{k=1}^n p_k - \sum_{k=1}^m z_k \right),$$

where  $n_e = n - m$  is the pole excess of the transfer function.

**12.12** (Real line segments of root locus) Consider proportional control a process with a rational transfer function. Assume that  $b_0k > 0$ , show that the root locus has segments on the real line there are an odd number of real poles and zeros to the right the segment.

**12.13** (Initial direction of root locus) Consider proportional control of a system with the transfer function

$$P(s) = \frac{b(s)}{a(s)} = \frac{b_0s^m + b_1s^{m-1} + \cdots + b_m}{s^n + a_1s^{n-1} + \cdots + a_n} = b_0 \frac{(s - z_1)(s - z_2) \cdots (s - z_m)}{(s - p_1)(s - p_2) \cdots (s - p_n)}.$$

Let  $p_j$  be an isolated pole and assume that  $kb_p > 0$ . Show that the root locus starting at  $p_j$  has the initial direction.

$$\angle(s - p_j) = \pi + \sum_{k=1}^m \angle(p_j - z_k) - \sum_{k \neq j} \angle(p_j - p_k).$$

Give a geometric interpretation of the result.

**12.14** Consider a lead compensator with the transfer function

$$C_n(s) = \left( \frac{s\sqrt[n]{k} + a}{s + a} \right)^n,$$

which has zero frequency gain  $C(0) = 1$  and high-frequency gain  $C(\infty) = k$ . Show that the gain required to give a given phase lead  $\varphi$  is

$$k = \left( 1 + 2 \tan^2(\varphi/n) + 2 \tan(\varphi/n) \sqrt{1 + \tan^2(\varphi/n)} \right)^n,$$

and that  $\lim_{n \rightarrow \infty} k = e^{2\varphi}$ .

**12.15** Consider a process with the loop transfer function

$$L(s) = k \frac{z - s}{s - p},$$

with positive  $z$  and  $p$ . Show that the system is stable if  $p/z < k < 1$  or  $1 < k < p/z$ , and that the largest stability margin is  $s_m = |p - z|/(p + z)$  is obtained for  $k = 2p/(p + z)$ . Determine the pole/zero ratios that gives the stability margin  $s_m = 2/3$ .

**12.16** Prove the inequalities given by equation (12.24). (Hint: Use the maximum modulus theorem.) 

**12.17** (Phase margin formulas) Show that the relationship between the phase margin and the values of the sensitivity functions at gain crossover is given by

$$|S(i\omega_{gc})| = |T(i\omega_{gc})| = \frac{1}{2 \sin(\varphi_m/2)}.$$

**12.18** (Stabilization of an inverted pendulum with visual feedback) Consider stabilization of an inverted pendulum based on visual feedback using a video camera with a 50-Hz frame rate. Let the effective pendulum length be  $l$ . Assume that we want the loop transfer function to have a slope of  $n_{gc} = -1/2$  at the crossover frequency. Use the gain crossover frequency inequality to determine the minimum length of the pendulum that can be stabilized if we desire a phase margin of  $45^\circ$ .

**12.19** (Rear-steered bicycle) Consider the simple model of a bicycle in Equation (4.5), which has one pole in the right half-plane. The model is also valid for a bicycle with rear wheel steering, but the sign of the velocity is then reversed and the system also has a zero in the right half-plane. Use the results of Exercise 12.15 to give a condition on the physical parameters that admits a controller with the stability margin  $s_m$ .

**12.20** Prove the formula (12.26) for the complementary sensitivity. 





---

## Chapter Thirteen

### Robust Performance

*However, by building an amplifier whose gain is deliberately made, say 40 decibels higher than necessary (10000 fold excess on energy basis), and then feeding the output back on the input in such a way as to throw away that excess gain, it has been found possible to effect extraordinary improvement in constancy of amplification and freedom from non-linearity.*

Harold S. Black, “Stabilized Feedback Amplifiers,” 1934 [Bla34].

This chapter focuses on the analysis of robustness of feedback systems, a vast topic for which we provide only an introduction to some of the key concepts. We consider the stability and performance of systems whose process dynamics are uncertain and derive fundamental limits for robust stability and performance. To do this we develop ways to describe uncertainty, both in the form of parameter variations and in the form of neglected dynamics. We also briefly mention some methods for designing controllers to achieve robust performance.

#### 13.1 Modeling Uncertainty

Harold Black’s quote above illustrates that one of the key uses of feedback is to provide robustness to uncertainty (“constancy of amplification”). It is one of the most useful properties of feedback and is what makes it possible to design feedback systems based on strongly simplified models.

One form of uncertainty in dynamical systems is *parametric uncertainty* in which the parameters describing the system are not precisely known. A typical example is the variation of the mass of a car, which changes with the number of passengers and the weight of the baggage. When linearizing a nonlinear system, the parameters of the linearized model also depend on the operating conditions. It is straightforward to investigate the effects of parametric uncertainty simply by evaluating the performance criteria for a range of parameters. Such a calculation reveals the consequences of parameter variations. We illustrate by a simple example.

##### Example 13.1 Cruise control

The cruise control problem is described in Section 4.1, and a PI controller was designed in Example 11.3. To investigate the effect of parameter variations, we will choose a controller designed for a nominal operating condition corresponding to mass  $m = 1600$  kg, fourth gear ( $\alpha = 12$ ) and speed  $v_e = 25$  m/s; the controller gains are  $k_p = 0.72$  and  $k_i = 0.18$ . Figure 13.1a shows the velocity error  $e$  and the throttle  $u$  when encountering a hill with a  $3^\circ$  slope with masses in the range  $1600 <$

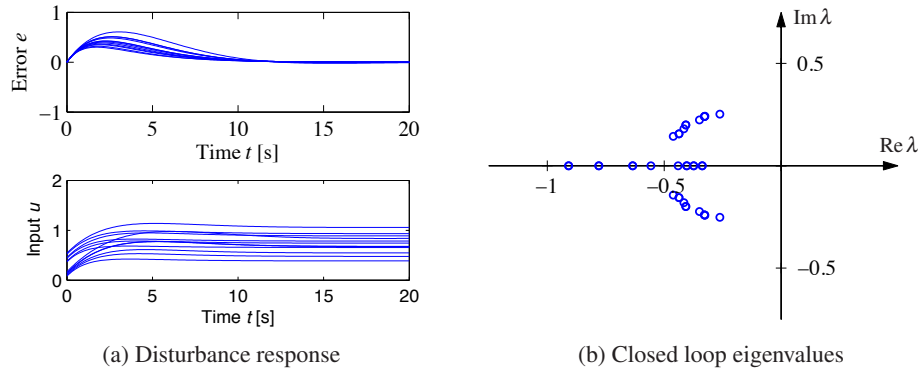

**Figure 13.1:** Responses of the cruise control system to a slope increase of  $3^\circ$  (a) and the eigenvalues of the closed loop system (b). Model parameters are swept over a wide range. The closed loop system is of second order.

$m < 2000$  kg, gear ratios 3–5 ( $\alpha = 10, 12$  and  $16$ ) and velocity  $10 \leq v \leq 40$  m/s. The simulations were done using models that were linearized around the different operating conditions. The figure shows that there are variations in the response but that they are quite reasonable. The largest velocity error is in the range of 0.2–0.6 m/s, and the settling time is about 15 s. The control signal is marginally larger than 1 in some cases, which implies that the throttle is fully open. A full nonlinear simulation using a controller with windup protection is required if we want to explore these cases in more detail. The closed loop system has two eigenvalues Figure 13.1bb shows these eigenvalues for the different operating conditions. The figure shows that the closed loop system is well damped in all cases.  $\nabla$

This example indicates that at least as far as parametric variations are concerned, the design based on a simple nominal model will give satisfactory control. The example also indicates that a controller with fixed parameters can be used in all cases. Notice that we have not considered operating conditions in low gear and at low speed, but cruise controllers are not typically used in these cases.

### Unmodeled Dynamics

It is generally easy to investigate the effects of parametric variations. However, there are other uncertainties that also are important, as discussed at the end of Section 3.3. The simple model of the cruise control system captures only the dynamics of the forward motion of the vehicle and the torque characteristics of the engine and transmission. It does not, for example, include a detailed model of the engine dynamics (whose combustion processes are extremely complex) or the slight delays that can occur in modern electronically controlled engines (as a result of the processing time of the embedded computers). These neglected mechanisms are called *unmodeled dynamics*.

Unmodeled dynamics can be accounted for by developing a more complex model. Such models are commonly used for controller development, but substan-

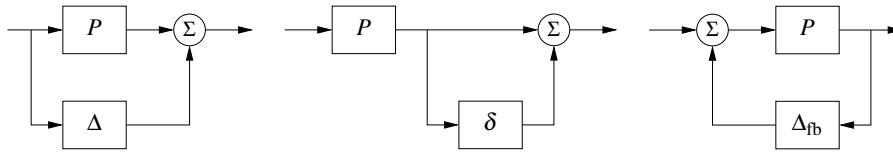

**Figure 13.2:** Unmodeled dynamics in linear systems. Uncertainty can be represented using additive perturbations (left), multiplicative perturbations (middle) or feedback perturbations (right). The nominal system is  $P$ , and  $\Delta$ ,  $\delta$  and  $\Delta_{fb}$  represent unmodeled dynamics.

tial effort is required to develop them. An alternative is to investigate if the closed loop system is sensitive to generic forms of unmodeled dynamics. The basic idea is to describe the unmodeled dynamics by including a transfer function in the system description whose frequency response is bounded but otherwise unspecified. For example, we might model the engine dynamics in the cruise control example as a system that quickly provides the torque that is requested through the throttle, giving a small deviation from the simplified model, which assumed the torque response was instantaneous. This technique can also be used in many instances to model parameter variations, allowing a quite general approach to uncertainty management.

In particular, we wish to explore if additional linear dynamics may cause difficulties. A simple way is to assume that the transfer function of the process is  $P(s) + \Delta$ , where  $P(s)$  is the nominal simplified transfer function and  $\Delta$  represents the unmodeled dynamics in terms of *additive uncertainty*. Different representations of uncertainty are shown in Figure 13.2. The relations between the different representations of unmodeled dynamics are

$$\delta = \frac{\Delta}{P}, \quad \Delta_{fb} = -\frac{\Delta}{P(P + \Delta)} = -\frac{\delta}{P(1 + \delta)}.$$

### When Are Two Systems Similar? The Vinnicombe Metric



A fundamental issue in describing robustness is to determine when two systems are close. Given such a characterization, we can then attempt to describe robustness according to how close the actual system must be to the model in order to still achieve the desired levels of performance. This seemingly innocent problem is not as simple as it may appear. A naive approach is to say that two systems are close if their open loop responses are close. Even if this appears natural, there are complications, as illustrated by the following examples.

#### Example 13.2 Similar in open loop but large differences in closed loop

The systems with the transfer functions

$$P_1(s) = \frac{k}{s+1}, \quad P_2(s) = \frac{k}{(s+1)(sT+1)^2} \quad (13.1)$$

have very similar open loop step responses for small values of  $T$ , as illustrated in the top plot in Figure 13.3a, which is plotted for  $T = 0.025$  and  $k = 100$ . The dif-

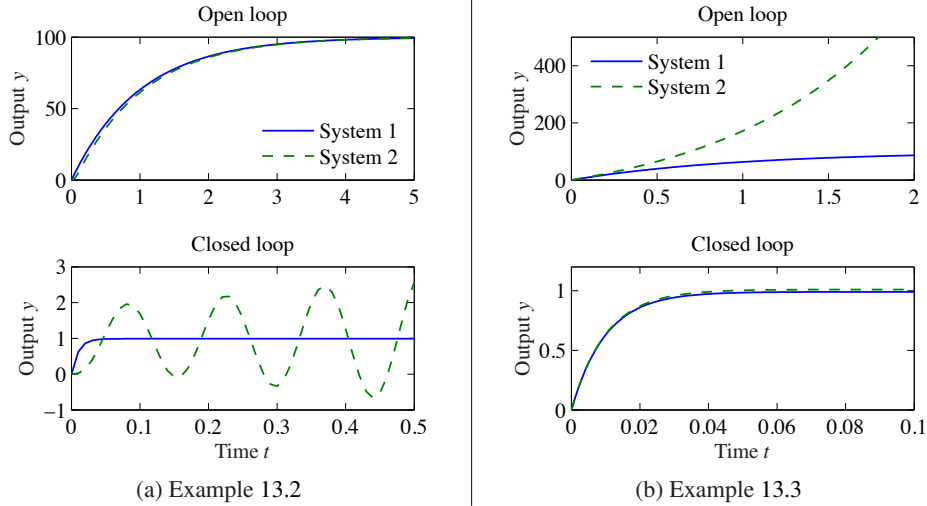

**Figure 13.3:** Determining when two systems are close. The plots in (a) show a situation when the open loop responses are almost identical, but the closed loop responses are very different. The processes are given by equation (13.1) with  $k = 100$  and  $T = 0.025$ . The plots in (b) show the opposite situation: the systems are different in open loop but similar in closed loop. The processes are given by equation (13.2) with  $k = 100$ .

ferences between the step responses are barely noticeable in the figure. The step responses with unit gain error feedback are shown in the bottom plot in Figure 13.3a. Notice that one closed loop system is stable and the other one is unstable.  $\nabla$

### Example 13.3 Different in open loop but similar in closed loop

Consider the systems

$$P_1(s) = \frac{k}{s+1}, \quad P_2(s) = \frac{k}{s-1}. \quad (13.2)$$

The open loop responses are very different because  $P_1$  is stable and  $P_2$  is unstable, as shown in the top plot in Figure 13.3b. Closing a feedback loop with unit gain around the systems, we find that the closed loop transfer functions are

$$T_1(s) = \frac{k}{s+k+1}, \quad T_2(s) = \frac{k}{s+k-1},$$

which are very close for large  $k$ , as shown in Figure 13.3b.  $\nabla$

These examples show that if our goal is to close a feedback loop, it may be very misleading to compare the open loop responses of the system.

Inspired by these examples we introduce the *Vinnicombe metric*, which is a distance measure that is appropriate for closed loop systems. Consider two systems with the transfer functions  $P_1$  and  $P_2$ , and define

$$d(P_1, P_2) = \sup_{\omega} \frac{|P_1(i\omega) - P_2(i\omega)|}{\sqrt{(1 + |P_1(i\omega)|^2)(1 + |P_2(i\omega)|^2)}}, \quad (13.3)$$

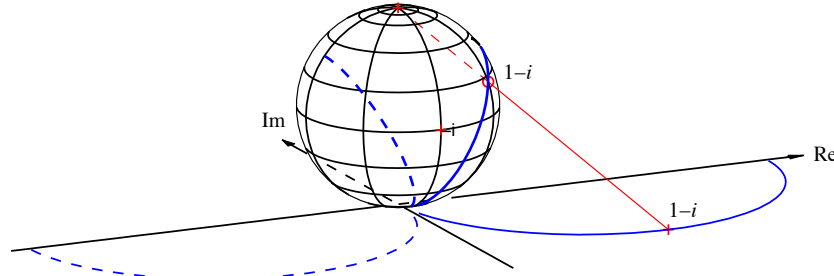

**Figure 13.4:** Geometric interpretation of  $d(P_1, P_2)$ . At each frequency, the points on the Nyquist curve for  $P_1$  (solid) and  $P_2$  (dashed) are projected onto a sphere of radius 1 sitting at the origin of the complex plane. The projection of the point  $1 - i$  is shown. The distance between the two systems is defined as the maximum distance between the projections of  $P_1(i\omega)$  and  $P_2(i\omega)$  over all frequencies  $\omega$ . The figure is plotted for the transfer functions  $P_1(s) = 2/(s+1)$  and  $P_2(s) = 2/(s-1)$ . (Diagram courtesy G. Vinnicombe.)

which is a metric with the property  $0 \leq d(P_1, P_2) \leq 1$ . The number  $d(P_1, P_2)$  can be interpreted as the difference between the complementary sensitivity functions for the closed loop systems that are obtained with unit feedback around  $P_1$  and  $P_2$ ; see Exercise 13.3. The metric also has a nice geometric interpretation, as shown in Figure 13.4, where the Nyquist plots of  $P_1$  and  $P_2$  are projected onto a sphere with radius 1 sitting at the origin of the complex plane (called the *Riemann sphere*). Points in the complex plane are projected onto the sphere by a line through the point and the north pole (Figure 13.4). The distance  $d(P_1, P_2)$  is the longest chordal distance between the projections of  $P_1(i\omega)$  and  $P_2(i\omega)$ . The distance is small when  $P_1(i\omega)$  and  $P_2(i\omega)$  are both small or both large.

The distance  $d(P_1, P_2)$  has one drawback for the purpose of comparing the behavior of systems under feedback. If  $P_2$  is perturbed continuously from  $P_1$  to  $P_2$ , there can be intermediate transfer functions  $P$  where  $d(P_1, P)$  is 1 even if  $d(P_1, P_2)$  is small (see Exercise 13.4). To explore when this could happen, we observe that

$$1 - d^2(P_1, P) = \frac{(1 + P(i\omega)P_1(-i\omega))(1 + P(-i\omega)P_1(i\omega))}{(1 + |P_1(i\omega)|^2)(1 + |P(i\omega)|^2)}.$$

The right-hand side is zero, and hence  $d(P_1, P) = 1$  if  $1 + P(i\omega)P_1(-i\omega) = 0$  for some  $\omega$ . To explore when this could occur, we investigate the behavior of the function  $1 + P(s)P_1(-s)$  when  $P$  is perturbed from  $P_1$  to  $P_2$ . If the functions  $f_1(s) = 1 + P_1(s)P_1(-s)$  and  $f_2(s) = 1 + P_2(s)P_1(-s)$  do not have the same number of zeros in the right half-plane, there is an intermediate  $P$  such that  $1 + P(i\omega)P_1(-i\omega) = 0$  for some  $\omega$ . To exclude this case we introduce the set  $\mathcal{C}$  as all pairs  $(P_1, P_2)$  such that the functions  $f_1 = 1 + P_1(s)P_1(-s)$  and  $f_2 = 1 + P_2(s)P_1(-s)$  have the same number of zeros in the right half-plane.

The *Vinnicombe metric* or *v-gap metric* is defined as

$$\delta_v(P_1, P_2) = \begin{cases} d(P_1, P_2), & \text{if } (P_1, P_2) \in \mathcal{C} \\ 1, & \text{otherwise.} \end{cases} \quad (13.4)$$

Vinnicombe [Vin01] showed that  $\delta_v(P_1, P_2)$  is a metric, he gave strong robustness results based on the metric and he developed the theory for systems with many inputs and many outputs. We illustrate its use by computing the metric for the systems in the previous examples.

### Example 13.4 Vinnicombe metric for Examples 13.2 and 13.3

For the systems in Example 13.2 we have

$$f_1(s) = 1 + P_1(s)P_1(-s) = \frac{1 + k^2 - s^2}{1 - s^2},$$

$$f_2(s) = 1 + P_2(s)P_1(-s) = \frac{1 + k^2 + 2sT + (T^2 - 1)s^2 - 2s^3T - s^4T^2}{(1 - s^2)(1 + 2sT + s^2T^2)}.$$

The function  $f_1$  has one zero in the right half-plane. A numerical calculation for  $k = 100$  and  $T = 0.025$  shows that the function  $f_2$  has the roots 46.3, -86.3,  $-20.0 \pm 60.0i$ . Both functions have one zero in the right half-plane, allowing us to compute the norm (13.4). For  $T = 0.025$  this gives  $\delta_v(P_1, P_2) = 0.98$ , which is a quite large value. To have reasonable robustness Vinnicombe recommended values less than  $1/3$ .

For the system in Example 13.3 we have

$$1 + P_1(s)P_1(-s) = \frac{1 + k^2 - s^2}{1 - s^2}, \quad 1 + P_2(s)P_1(-s) = \frac{1 - k^2 - 2s + s^2}{(s + 1)^2}$$

These functions have the same number of zeros in the right half-plane if  $k > 1$ . In this particular case the Vinnicombe metric is  $d(P_1, P_2) = 2k/(1 + k^2)$  (Exercise 13.4) and with  $k = 100$  we get  $\delta_v(P_1, P_2) = 0.02$ . Figure 13.4 shows the Nyquist curves and their projections for  $k = 2$ . Notice that  $d(P_1, P_2)$  is very small for small  $k$  even though the closed loop systems are very different. It is therefore essential to consider the condition  $(P_1, P_2) \in \mathcal{C}$ , as discussed in Exercise 13.4.  $\nabla$

## 13.2 Stability in the Presence of Uncertainty

Having discussed how to describe uncertainty and the similarity between two systems, we now consider the problem of robust stability: When can we show that the stability of a system is robust with respect to process variations? This is an important question since the potential for instability is one of the main drawbacks of feedback. Hence we want to ensure that even if we have small inaccuracies in our model, we can still guarantee stability and performance of the closed loop system.

### Robust Stability Using Nyquist's Criterion

The Nyquist criterion provides a powerful and elegant way to study the effects of uncertainty for linear systems. A simple criterion is that the Nyquist curve be sufficiently far from the critical point  $-1$ . Recall that the shortest distance from the Nyquist curve to the critical point is  $s_m = 1/M_s$ , where  $M_s$  is the maximum of

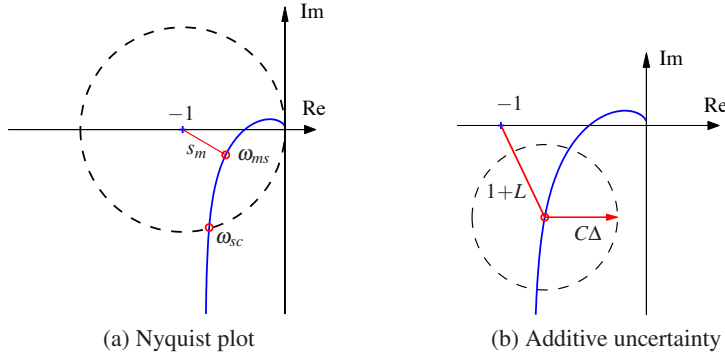

**Figure 13.5:** Robust stability using the Nyquist criterion. The plot (a) shows that the shortest distance to the critical point  $s_m$  is a robustness measure. The plot (b) shows the Nyquist curve of the nominal loop transfer function  $L$ , the circle shows its uncertainty due to additive process variations  $\Delta$ .

the sensitivity function and  $s_m$  is the stability margin introduced in Section 10.3. The maximum sensitivity  $M_s$  or the stability margin  $s_m$  is thus a good robustness measure, as illustrated in Figure 13.5a.

We will now derive explicit conditions on the controller  $C$  such that stability is guaranteed for process perturbations where  $|\Delta|$  is less than a given bound. Consider a stable feedback system with a process  $P$  and a controller  $C$ . If the process is changed from  $P$  to  $P + \Delta$ , the loop transfer function changes from  $PC$  to  $PC + C\Delta$ , as illustrated in Figure 13.5b. If we have a bound on the size of  $\Delta$  (represented by the dashed circle in the figure), then the system remains stable as long as the perturbed loop transfer function  $|1 + (P + \Delta)C|$  never reaches the critical point  $-1$ , since the number of encirclements of  $-1$  remain unchanged.

Some additional assumptions are required for the analysis to hold. Most importantly, we require that the process perturbations  $\Delta$  be stable so that we do not introduce any new right half-plane poles that would require additional encirclements in the Nyquist criterion.

We will now compute an analytical bound on the allowable process disturbances. The distance from the critical point  $-1$  to the loop transfer function  $L$  is  $|1 + L|$ . This means that the perturbed Nyquist curve will not reach the critical point  $-1$  provided that  $|C\Delta| < |1 + L|$ , which is guaranteed if

$$|\Delta| < \left| \frac{1 + PC}{C} \right| \quad \text{or} \quad |\delta| < \frac{1}{|T|}, \quad \text{where} \quad \delta := \left| \frac{\Delta}{P} \right|. \quad (13.5)$$

This condition must be valid for all points on the Nyquist curve, i.e., pointwise for all frequencies. The condition for robust stability can thus be written as

$$|\delta(i\omega)| = \left| \frac{\Delta(i\omega)}{P(i\omega)} \right| < \frac{1}{|T(i\omega)|} \quad \text{for all } \omega \geq 0. \quad (13.6)$$

Notice that the condition is conservative because it follows from Figure 13.5 that

the critical perturbation is in the direction toward the critical point  $-1$ . Larger perturbations can be permitted in the other directions.

The condition in equation (13.6) allows us to reason about uncertainty without exact knowledge of the process perturbations. Namely, we can verify stability for *any* uncertainty  $\Delta$  that satisfies the given bound. From an analysis perspective, this gives us a measure of the robustness for a given design. Conversely, if we require robustness of a given level, we can attempt to choose our controller  $C$  such that the desired level of robustness is available (by asking that  $T$  be small) in the appropriate frequency bands.

Equation (13.6) is one of the reasons why feedback systems work so well in practice. The mathematical models used to design control systems are often simplified, and the properties of a process may change during operation. Equation (13.6) implies that the closed loop system will at least be stable for substantial variations in the process dynamics.

It follows from equation (13.6) that the variations can be large for those frequencies where  $T$  is small and that smaller variations are allowed for frequencies where  $T$  is large. A conservative estimate of permissible process variations that will not cause instability is given by

$$|\delta(i\omega)| = \left| \frac{\Delta(i\omega)}{P(i\omega)} \right| < \frac{1}{M_t},$$

where  $M_t$  is the largest value of the complementary sensitivity

$$M_t = \sup_{\omega} |T(i\omega)| = \left\| \frac{PC}{1+PC} \right\|_{\infty}. \quad (13.7)$$

Reasonable values of  $M_t$  are in the range of 1.2 to 2. It is shown in Exercise 13.5 that if  $M_t = 2$  then pure gain variations of 50% or pure phase variations of  $30^\circ$  are permitted without making the closed loop system unstable.

### Example 13.5 Cruise control

Consider the cruise control system discussed in Section 4.1. The model of the car in fourth gear at speed 25 m/s is

$$P(s) = \frac{1.38}{s + 0.0142},$$

and the controller is a PI controller with gains  $k_p = 0.72$  and  $k_i = 0.18$ . Figure 13.6 plots the allowable size of the process uncertainty using the bound in equation (13.6). At low frequencies,  $T(0) = 1$  and so the perturbations can be as large as the original process ( $|\delta| = |\Delta/P| < 1$ ). The complementary sensitivity has its maximum  $M_t = 1.14$  at  $\omega_{mt} = 0.35$ , and hence this gives the minimum allowable process uncertainty, with  $|\delta| < 0.87$  or  $|\Delta| < 3.47$ . Finally, at high frequencies,  $T \rightarrow 0$  and hence the relative error can get very large. For example, at  $\omega = 5$  we have  $|T(i\omega)| = 0.195$ , which means that the stability requirement is  $|\delta| < 5.1$ . The analysis clearly indicates that the system has good robustness and that the high-frequency properties of the transmission system are not important for the design



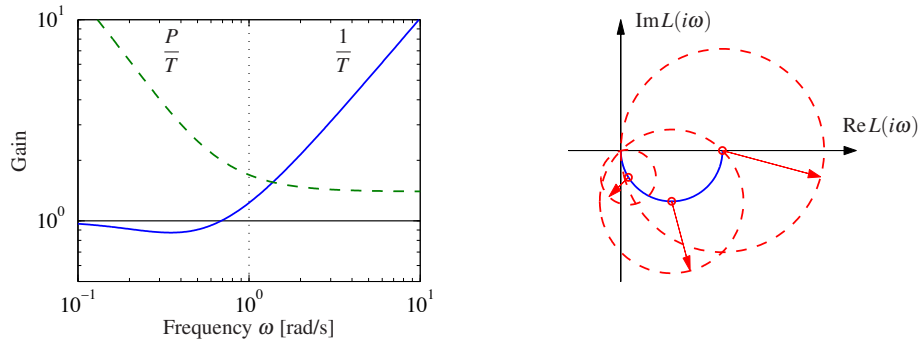

**Figure 13.6:** Robustness for a cruise controller. On the left the maximum relative error  $1/|T|$  (solid) and the absolute error  $|P|/|T|$  (dashed) for the process uncertainty  $\Delta$ . The Nyquist curve is shown on the right as a solid line. The dashed circles show permissible perturbations in the process dynamics,  $|\Delta| = |P|/|T|$ , at the frequencies  $\omega = 0, 0.0142$  and  $0.05$ .

of the cruise controller.

Another illustration of the robustness of the system is given in the right diagram in Figure 13.6, which shows the Nyquist curve of the transfer function of the process and the uncertainty bounds  $\Delta = |P|/|T|$  for a few frequencies. Note that the controller can tolerate large amounts of uncertainty and still maintain stability of the closed loop. ▽

The situation illustrated in the previous example is typical of many processes: moderately small uncertainties are required only around the gain crossover frequencies, but large uncertainties can be permitted at higher and lower frequencies. A consequence of this is that a simple model that describes the process dynamics well around the crossover frequency is often sufficient for design. Systems with many resonant peaks are an exception to this rule because the process transfer function for such systems may have large gains for higher frequencies also, as shown for instance in Example 10.9.

The robustness condition given by equation (13.6) can be given another interpretation by using the small gain theorem (Theorem 10.4). To apply the theorem we start with block diagrams of a closed loop system with a perturbed process and make a sequence of transformations of the block diagram that isolate the block representing the uncertainty, as shown in Figure 13.7. The result is the two-block interconnection shown in Figure 13.7c, which has the loop transfer function

$$L = \frac{PC}{1+PC} \frac{\Delta}{P} = T\delta.$$

Equation (13.6) implies that the largest loop gain is less than 1 and hence the system is stable via the small gain theorem.

The small gain theorem can be used to check robust stability for uncertainty in a variety of other situations. Table 13.1 summarizes a few of the common cases; the proofs (all via the small gain theorem) are left as exercises.

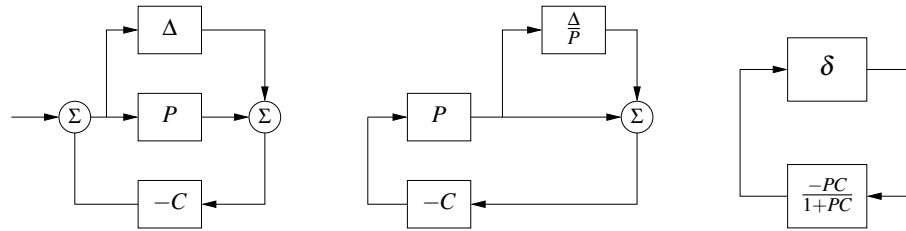

**Figure 13.7:** Illustration of robustness to process perturbations. A system with additive uncertainty (left) can be manipulated via block diagram algebra to one with multiplicative uncertainty  $\delta = \Delta/P$  (center). Additional manipulations isolate the uncertainty in a manner that allows application of the small gain theorem (right)

The following example illustrates that it is possible to design systems that are robust to parameter variations.

### Example 13.6 Bode's ideal loop transfer function

A major problem in the design of electronic amplifiers is to obtain a closed loop system that is insensitive to changes in the gain of the electronic components. Bode found that the loop transfer function  $L(s) = ks^{-n}$ , with  $1 \leq n \leq 5/3$ , was an ideal loop transfer function. The gain curve of the Bode plot is a straight line with slope  $-n$  and the phase is constant  $\arg L(i\omega) = -n\pi/2$ . The phase margin is thus  $\phi_m = 90(2-n)^\circ$  for all values of the gain  $k$  and the stability margin is  $s_m = \sin \pi(1-n/2)$ . This transfer function cannot be realized with physical components unless  $n$  is an integer, but it can be approximated over a given frequency range with a proper rational function (Exercise 13.7) for any  $n$ . An operational amplifier circuit that has the approximate transfer function  $G(s) = k/(s+a)$  is a realization of Bode's ideal transfer function with  $n = 1$ , as described in Example 9.3. Designers of operational amplifiers go to great efforts to make the approximation valid over a wide frequency range.  $\nabla$



### Youla Parameterization

Since stability is such an essential property, it is useful to characterize all controllers that stabilize a given process. Such a representation, which is called a *Youla parameterization*, is very useful when solving design problems because it makes it possible to search over all stabilizing controllers without the need to test stability

**Table 13.1:** Conditions for robust stability for different types of uncertainty

Process	Uncertainty Type	Robust Stability
$P + \Delta$	Additive	$\ CS\Delta\ _\infty < 1$
$P(1 + \delta)$	Multiplicative	$\ T\delta\ _\infty < 1$
$P/(1 + \Delta_{fb} \cdot P)$	Feedback	$\ PS\Delta_{fb}\ _\infty < 1$

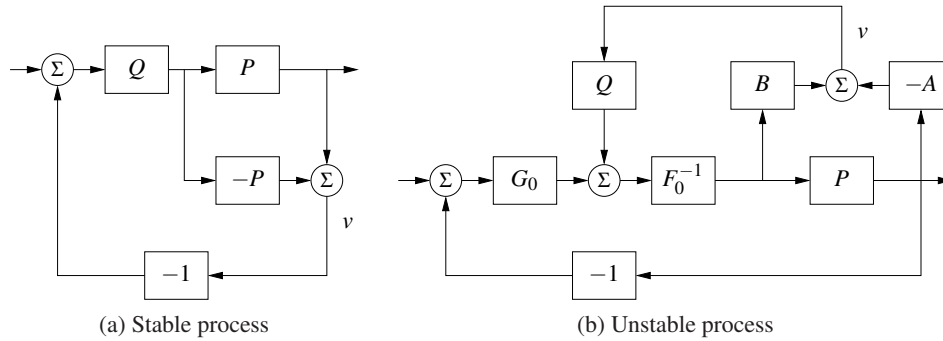

**Figure 13.8:** Youla parameterization. Block diagrams of Youla parameterizations for a stable system (a) and an unstable system (b). Notice that the signal  $v$  is zero in steady state.

explicitly.

We will first derive Youla's parameterization for a stable process with a rational transfer function  $P$ . A system with the complementary sensitivity function  $T$  can be obtained by feedforward control with the stable transfer function  $Q$  if  $T = PQ$ . Notice that  $T$  must have the same right half-plane zeros as  $P$  since  $Q$  is stable. Now assume that we want to implement the complementary transfer function  $T$  by using unit feedback with the controller  $C$ . Since  $T = PC/(1 + PC) = PQ$ , it follows that the controller transfer function is

$$C = \frac{Q}{1 - PQ}. \quad (13.8)$$

A straightforward calculation gives

$$S = 1 - PQ, \quad PS = P(1 - PQ), \quad CS = Q, \quad T = PQ.$$

These transfer functions are all stable if  $P$  and  $Q$  are stable and the controller given by equation (13.8) is thus stabilizing. Indeed, it can be shown that all stabilizing controllers are in the form given by equation (13.8) for some choice of  $Q$ . The parameterization is illustrated by the block diagrams in Figure 13.8a. Notice that the signal  $v$  is always zero.

A similar characterization can be obtained for unstable systems. Consider a process with a rational transfer function  $P(s) = a(s)/b(s)$ , where  $a(s)$  and  $b(s)$  are polynomials. By introducing a stable polynomial  $c(s)$ , we can write

$$P(s) = \frac{b(s)}{a(s)} = \frac{B(s)}{A(s)},$$

where  $A(s) = a(s)/c(s)$  and  $B(s) = b(s)/c(s)$  are stable rational functions. Similarly we introduce the controller  $C_0(s) = G_0(s)/F_0(s)$ , where  $F_0(s)$  and  $G_0(s)$  are

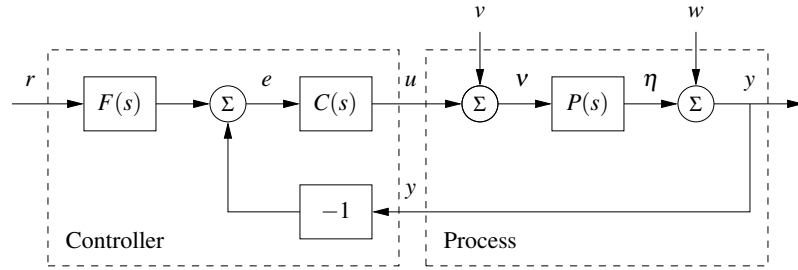

**Figure 13.9:** Block diagram of a basic feedback loop. The external signals are the reference signal  $r$ , the load disturbance  $v$  and the measurement noise  $w$ . The process output is  $y$ , and the control signal is  $u$ . The process  $P$  may include unmodeled dynamics, such as additive perturbations.

stable rational functions. We have

$$S_0 = \frac{1}{1 + P_0 C_0} = \frac{A F_0}{A F_0 + B G_0}, \quad P S_0 = \frac{B F_0}{A F_0 + B G_0},$$

$$C_0 S_0 = \frac{A G_0}{A F_0 + B G_0}, \quad T_0 = \frac{B G_0}{A F_0 + B G_0}.$$

The controller  $C_0$  is stabilizing if and only if the rational function  $A F_0 + B G_0$  does not have any zeros in the right half plane. Let  $Q$  be a stable rational function and consider the controller

$$C = \frac{G_0 + Q A}{F_0 - Q B}. \quad (13.9)$$

The Gang of Four for  $P$  and  $C$  is

$$S = \frac{A(F_0 - Q B)}{A F_0 + B G_0}, \quad P S = \frac{B(F_0 - Q B)}{A F_0 + B G_0},$$

$$C S = \frac{A(G_0 + Q A)}{A F_0 + B G_0}, \quad T = \frac{B(G_0 + Q A)}{A F_0 + B G_0}.$$

All these transfer functions are stable because  $A, B, F_0$  and  $G_0$  are stable and  $A F_0 + B G_0$  does not have any zeros in the right half plane. The controller  $C$  given by (13.9) thus stabilizes the closed loop system for any stable  $Q$ . A block diagram of the closed loop system with the controller  $C$  is shown in Figure 13.8b. Notice that the signal  $v$  is zero.

### 13.3 Performance in the Presence of Uncertainty

So far we have investigated the risk for instability and robustness to process uncertainty. We will now explore how responses to load disturbances, measurement noise and reference signals are influenced by process variations. To do this we will analyze the system in Figure 13.9, which is identical to the basic feedback loop analyzed in Chapter 12.

### Disturbance Attenuation

The sensitivity function  $S$  gives a rough characterization of the effect of feedback on disturbances, as was discussed in Section 12.3. A more detailed characterization is given by the transfer function from load disturbances to process output:

$$G_{yv} = \frac{P}{1+PC} = PS. \quad (13.10)$$

Load disturbances typically have low frequencies, and it is therefore important that the transfer function  $G_{yv}$  is small for low frequencies. For processes  $P$  with constant low-frequency gain and a controller with integral action it follows from (13.10) that  $G_{yv} \approx s/k_i$ . The integral gain  $k_i$  is thus a simple measure of the attenuation of low frequency load disturbances.

To find out how the transfer function  $G_{yv}$  is influenced by small variations in the process transfer function we differentiate equation (13.10) with respect to  $P$  yielding

$$\frac{dG_{yv}}{dP} = \frac{1}{(1+PC)^2} = \frac{SP}{P(1+PC)} = S \frac{G_{yv}}{P},$$

and it follows that

$$\frac{dG_{yv}}{G_{yv}} = S \frac{dP}{P}. \quad (13.11)$$

The response to load disturbances is thus insensitive to process variations for frequencies where  $|S(i\omega)|$  is small.

A drawback with feedback is that the controller feeds measurement noise into the system. It is thus also important that the control actions generated by measurement noise are not too large. It follows from Figure 13.9 that the transfer function  $G_{uw}$  from measurement noise to controller output is given by

$$G_{uw} = -\frac{C}{1+PC} = -\frac{T}{P}. \quad (13.12)$$

Since measurement noise typically has high frequencies, the transfer function  $G_{uw}$  should not be too large for high frequencies. The loop transfer function  $PC$  is typically small for high frequencies, which implies that  $G_{uw} \approx C$  for large  $s$ . To avoid injecting too much measurement noise the high frequency gain of the controller transfer function  $C(s)$  should thus be small. This property is called *high-frequency roll-off*. In PID control it is common practice to low-pass filter the measured signal; see Section 11.5.

To determine how the transfer function  $G_{uw}$  is influenced by small variations in the process transfer, we differentiate equation (13.12):

$$\frac{dG_{uw}}{dP} = \frac{d}{dP} \left( -\frac{C}{1+PC} \right) = \frac{C}{(1+PC)^2} C = -T \frac{G_{uw}}{P}.$$

Rearranging the terms gives

$$\frac{dG_{uw}}{G_{uw}} = -T \frac{dP}{P}. \quad (13.13)$$

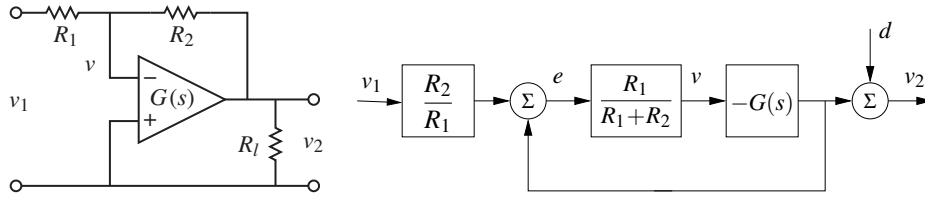

**Figure 13.10:** Operational amplifier with uncertain dynamics. The circuit on the left is modeled using the transfer function  $G(s)$  to capture its dynamic properties and it has a load at the output. The block diagram on the right shows the input/output relationships. The load is represented as a disturbance  $d$  applied at the output of  $G(s)$ .

Since the complementary sensitivity function is also small for high frequencies, we find that process uncertainty has little influence on the transfer function  $G_{uw}$  for frequencies where measurements are important.

### Reference Signal Tracking

The transfer function from reference to output is given by

$$G_{yr} = \frac{PCF}{1 + PC} = TF, \quad (13.14)$$

which contains the complementary sensitivity function. To see how variations in  $P$  affect the performance of the system, we differentiate equation (13.14) with respect to the process transfer function:

$$\frac{dG_{yr}}{dP} = \frac{CF}{1 + PC} - \frac{PCFC}{(1 + PC)^2} = \frac{CF}{(1 + PC)^2} = S \frac{G_{yr}}{P},$$

and it follows that

$$\frac{dG_{yr}}{G_{yr}} = S \frac{dP}{P}. \quad (13.15)$$

The relative error in the closed loop transfer function thus equals the product of the sensitivity function and the relative error in the process. In particular, it follows from equation (13.15) that the relative error in the closed loop transfer function is small when the sensitivity is small. This is one of the useful properties of feedback.

As in the previous section, there are some mathematical assumptions that are required for the analysis presented here to hold. As already stated, we require that the perturbations  $\Delta$  be small (as indicated by writing  $dP$ ). Second, we require that the perturbations be stable, so that we do not introduce any new right half-plane poles that would require additional encirclements in the Nyquist criterion. Also, as before, this condition is conservative: it allows for any perturbation that satisfies the given bounds, while in practice the perturbations may be more restricted.

### Example 13.7 Operational amplifier circuit

To illustrate the use of these tools, consider the performance of an op amp-based amplifier, as shown in Figure 13.10. We wish to analyze the performance of the amplifier in the presence of uncertainty in the dynamic response of the op amp

and changes in the loading on the output. We model the system using the block diagram in Figure 13.10b, which is based on the derivation in Example 10.1.

Consider first the effect of unknown dynamics for the operational amplifier. Let the dynamics of the op amp be modeled as  $v_2 = -G(s)v_1$ , it then follows from the block diagram in Figure 13.10b that the transfer function for the overall circuit is

$$G_{v_2v_1} = -\frac{R_2}{R_1} \frac{G(s)}{G(s) + R_2/R_1 + 1}.$$

We see that if  $G(s)$  is large over the desired frequency range, then the closed loop system is very close to the ideal response  $\alpha = R_2/R_1$ . Assuming  $G(s) = b/(s+a)$ , where  $b$  is the gain-bandwidth product of the amplifier, as discussed in Example 9.3, the sensitivity function and the complementary sensitivity function become

$$S = \frac{s+a}{s+a+\alpha b}, \quad T = \frac{\alpha b}{s+a+\alpha b}.$$

The sensitivity function around the nominal values tells us how the tracking response varies as a function of process perturbations:

$$\frac{dG_{yr}}{G_{yr}} = S \frac{dP}{P}.$$

We see that for low frequencies, where  $S$  is small, variations in the bandwidth  $a$  or the gain-bandwidth product  $b$  will have relatively little effect on the performance of the amplifier (under the assumption that  $b$  is sufficiently large).

To model the effects of an unknown load, we consider the addition of a disturbance at the output of the system, as shown in Figure 13.10b. This disturbance represents changes in the output voltage due to loading effects. The transfer function  $G_{yd} = S$  gives the response of the output to the load disturbance, and we see that if  $S$  is small, then we are able to reject such disturbances. The sensitivity of  $G_{yd}$  to perturbations in the process dynamics can be computed by taking the derivative of  $G_{yd}$  with respect to  $P$ :

$$\frac{dG_{yd}}{dP} = \frac{-C}{(1+PC)^2} = -\frac{T}{P} G_{yd} \quad \implies \quad \frac{dG_{yd}}{G_{yd}} = -T \frac{dP}{P}.$$

Thus we see that the relative changes in the disturbance rejection are roughly the same as the process perturbations at low frequency (when  $T$  is approximately 1) and drop off at higher frequencies. However, it is important to remember that  $G_{yd}$  itself is small at low frequency, and so these variations in relative performance may not be an issue in many applications.  $\nabla$

## 13.4 Robust Pole Placement

In Chapters 7 and 8 we saw how to design controllers by setting the locations of the eigenvalues of the closed loop system. If we analyze the resulting system in the frequency domain, the closed loop eigenvalues correspond to the poles of

the closed loop transfer function and hence these methods are often referred to as design by *pole placement*.

State space design methods, like many methods developed for control system design, do not explicitly take robustness into account. In such cases it is essential to always investigate the robustness because there are seemingly reasonable designs that give controllers with poor robustness. We illustrate this by analyzing controllers designed by state feedback and observers. The closed loop poles can be assigned to arbitrary locations if the system is observable and reachable. However, if we want to have a robust closed loop system, the poles and zeros of the process impose severe restrictions on the location of the closed loop poles. Some examples are first given; based on the analysis of these examples we then present design rules for robust pole (eigenvalue) placement.

### Slow Stable Process Zeros

We will first explore the effects of slow stable zeros, and we begin with a simple example.

#### Example 13.8 Vehicle steering

Consider the linearized model for vehicle steering in Example 9.10, which has the transfer function

$$P(s) = \frac{0.5s + 1}{s^2}.$$

A controller based on state feedback was designed in Example 7.4, and state feedback was combined with an observer in Example 8.4. The system simulated in Figure 8.8 has closed loop poles specified by  $\omega_c = 0.3$ ,  $\zeta_c = 0.707$ ,  $\omega_o = 7$  and  $\zeta_o = 9$ . Assume that we want a faster closed loop system and choose  $\omega_c = 10$ ,  $\zeta_c = 0.707$ ,  $\omega_o = 20$  and  $\zeta_o = 0.707$ . Using the state representation in Example 8.3, a pole placement design gives state feedback gains  $k_1 = 100$  and  $k_2 = -35.86$  and observer gains  $l_1 = 28.28$  and  $l_2 = 400$ . The controller transfer function is

$$C(s) = \frac{-11516s + 40000}{s^2 + 42.4s + 6657.9}.$$

Figure 13.11 shows Nyquist and Bode plots of the loop transfer function. The Nyquist plot indicates that the robustness is poor since the loop transfer function is very close to the critical point  $-1$ . The phase margin is  $7^\circ$  and the stability margin is  $s_m = 0.077$ . The poor robustness shows up in the Bode plot, where the gain curve hovers around the value 1 and the phase curve is close to  $-180^\circ$  for a wide frequency range. More insight is obtained by analyzing the sensitivity functions, shown by solid lines in Figure 13.12. The maximum sensitivities are  $M_s = 13$  and  $M_t = 12$ , indicating that the system has poor robustness.

At first sight it may be surprising that a controller where the nominal closed system has well damped poles and zeros is so sensitive to process variations. We have an indication that something is unusual because the controller has a slow zero at  $s = 3.5$ , recall that the observer and controller poles have  $\omega_c = 10$  and  $\omega_o = 20$ .



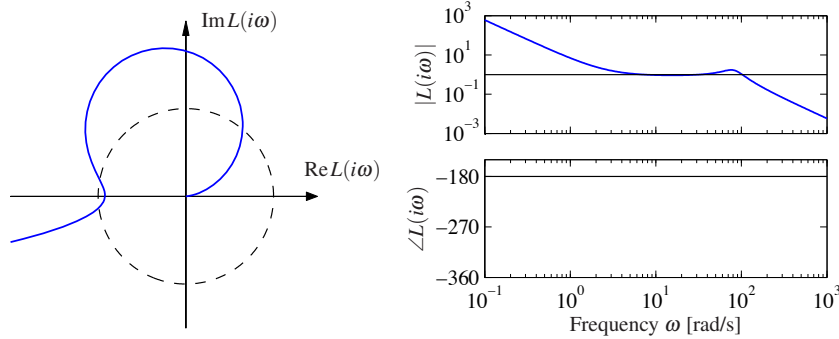

**Figure 13.11:** Observer-based control of steering. The Nyquist plot (left) and Bode plot (right) of the loop transfer function for vehicle steering with a controller based on state feedback and an observer. The controller provides stable operation, but with very low gain and phase margin.

To understand what happens, we will investigate the reason for the peaks of the sensitivity functions.

Let the transfer functions of the process and the controller be

$$P(s) = \frac{n_p(s)}{d_p(s)}, \quad C(s) = \frac{n_c(s)}{d_c(s)},$$

where  $n_p(s)$ ,  $n_c(s)$ ,  $d_p(s)$  and  $d_c(s)$  are the numerator and denominator polynomials. The complementary sensitivity function is

$$T(s) = \frac{PC}{1+PC} = \frac{n_p(s)n_c(s)}{d_p(s)d_c(s) + n_p(s)n_c(s)}.$$

The poles of  $T(s)$  are the poles of the closed loop system and the zeros are the zeros of the process and of the controller. A Bode plot of the gain curve of  $T$  is shown in Figure 13.12a. We have  $T(0) = 1$ , because  $L(0) = P(0)C(0) = \infty$ , due to the double integrator of  $P$ . The gain  $|T(i\omega)|$  increases for increasing  $\omega$  due to the process zero at  $\omega = 2$ . It increases further at the controller zero at  $\omega = 3.5$ , and it does not start to decrease until the closed loop poles appear at  $\omega = 10$  and  $\omega = 20$ . The gain of the complementary sensitivity function has a peak indicating poor sensitivity of the closed loop system.

The peak of the complementary sensitivity function can be avoided by assigning a closed loop pole at the slow process zero or close to it. We can achieve this by choosing  $\omega_c = 10$  and  $\zeta_c = 2.6$ , which gives closed loop poles at  $s = -2$  and  $s = -50$ . The controller transfer function then becomes

$$C(s) = \frac{3628s + 40000}{s^2 + 80.28s + 156.56} = 3628 \frac{s + 11.02}{(s + 2)(s + 78.28)}.$$

The sensitivity functions are shown by dashed lines in Figure 13.12b. The closed loop system has the maximum sensitivities  $M_s = 1.34$  and  $M_t = 1.41$ , which indicate good robustness. Notice that the controller has a pole at  $s = -2$  that cancels

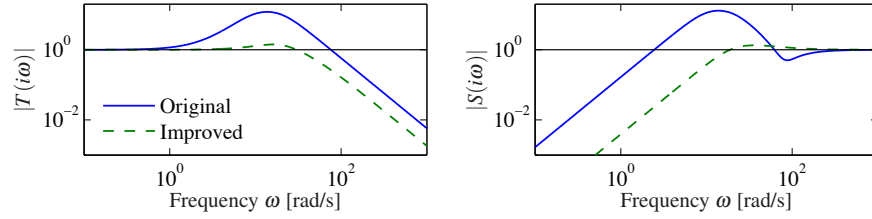

**Figure 13.12:** Gain curves of Bode plots for the sensitivity functions of observer-based control of vehicle steering. The complementary sensitivity function is shown in (a) and the sensitivity function in (b). The plots for the original controller with  $\omega_c = 10$ ,  $\zeta_c = 0.707$ ,  $\omega_o = 20$ ,  $\zeta_o = 0.707$  is shown in solid lines and the improved controller with  $\omega_c = 10$ ,  $\zeta_c = 2.6$  is shown in dashed lines.

the slow process zero. The design can be done simply by first canceling the slow stable process zero and then designing the controller.  $\nabla$

One lesson from the example is that it is necessary to choose closed loop poles that are equal to or close to slow stable process zeros. Another lesson is that slow unstable process zeros impose limitations on the achievable bandwidth, as already noted in Section 12.6.

### Fast Stable Process Poles

The next example shows the effect of fast stable poles.

#### Example 13.9 Fast system poles

Consider a PI controller for a first-order system, where the process and the controller have the transfer functions  $P(s) = b/(s+a)$ , with  $a > 0$ , and  $C(s) = k_p + k_i/s$ . The loop transfer function is

$$L(s) = \frac{b(k_p s + k_i)}{s(s+a)},$$

and the closed loop characteristic polynomial is.

$$s(s+a) + b(k_p s + k_i) = s^2 + (a + bk_p)s + k_i b$$

If we specify the desired closed loop poles should be  $-p_1$  and  $-p_2$ , we find that the controller parameters are given by

$$k_p = \frac{p_1 + p_2 - a}{b}, \quad k_i = \frac{p_1 p_2}{b}.$$

The sensitivity functions are then

$$S(s) = \frac{s(s+a)}{(s+p_1)(s+p_2)}, \quad T(s) = \frac{(p_1 + p_2 - a)s + p_1 p_2}{(s+p_1)(s+p_2)}.$$

Assume that the process pole  $-a$  is much more negative than the closed loop poles  $-p_1$  and  $-p_2$ , say,  $p_1 < p_2 \ll a$ . Notice that the proportional gain  $k_p$  is negative

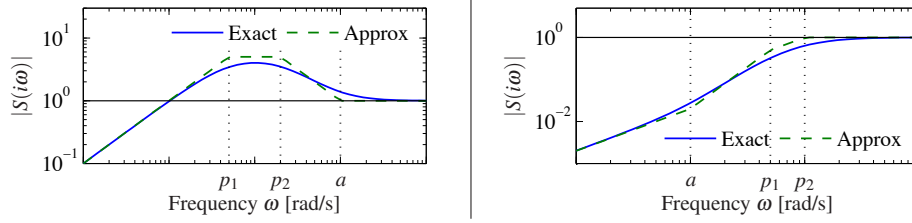

**Figure 13.13:** Gain curves of Bode plots of the sensitivity function  $S$  for designs with  $p_1 < p_2 < a$  (left) and  $a < p_1 < p_2$  (right). The solid lines are the true sensitivities, and the dashed lines are the asymptotes.

and that the controller has a zero in the right half-plane if  $a > p_1 + p_2$ , an indication that the system has bad properties.

Next consider the sensitivity function, which is 1 for high frequencies. Figure 13.13a shows that the increases for  $\omega = a$  corresponding to the process pole. The sensitivity does not decrease until the breakpoints of closed loop poles are reached, resulting in a large sensitivity peak that is approximately  $a/p_2$ . The gain of the sensitivity function is shown in Figure 13.13 for  $a = b = 1$ ,  $p_1 = 0.05$  and  $p_2 = 0.2$ . Notice the high-sensitivity peak. For comparison we also show the gain curve for the case when the closed loop poles ( $p_1 = 5$ ,  $p_2 = 20$ ) are faster than the process pole ( $a = 1$ ).

The problem with poor robustness can be avoided by choosing one closed loop pole equal to the process pole, i.e.,  $p_2 = a$ . The controller gains then become

$$k_p = \frac{p_1}{b}, \quad k_i = \frac{ap_1}{b},$$

which means that the fast process pole is canceled by a controller zero at  $s = -a$ . The loop transfer function and the sensitivity functions are

$$L(s) = \frac{bk_p}{s}, \quad S(s) = \frac{s}{s + bk_p}, \quad T(s) = \frac{bk_p}{s + bk_p}.$$

The maximum sensitivities are now less than 1 for all frequencies. Notice that this is possible because the process transfer function goes to zero as  $s^{-1}$ .  $\nabla$

### Design Rules for Pole Placement

Based on the insight gained from the examples, it is now possible to obtain design rules that give designs with good robustness. Consider the expression (13.7) for maximum complementary sensitivity, repeated here:

$$M_t = \sup_{\omega} |T(i\omega)| = \left\| \frac{PC}{1 + PC} \right\|_{\infty}.$$

Let  $\omega_{gc}$  be the desired gain crossover frequency. Assume that the process has zeros that are slower than  $\omega_{gc}$ . The complementary sensitivity function is 1 for low frequencies, and it increases for frequencies close to the process zeros unless there

is a closed loop pole in the neighborhood. To avoid large values of the complementary sensitivity function we find that the closed loop system should therefore have poles close to or equal to the slow stable zeros. This means that slow stable zeros should be canceled by controller poles. Since unstable zeros cannot be canceled, the presence of slow unstable zeros means that achievable gain crossover frequency must be smaller than the slowest unstable process zero.

Now consider process poles that are faster than the desired gain crossover frequency. Consider the expression for the maximum of the sensitivity function:

$$M_s = \sup_{\omega} |S(i\omega)| = \left\| \frac{1}{1 + PC} \right\|_{\infty}.$$

The sensitivity function is 1 for high frequencies. Moving from high to low frequencies, the sensitivity function increases at the fast process poles. Large peaks can result unless there are closed loop poles close to the fast process poles. To avoid large peaks in the sensitivity the closed loop system should therefore have poles that match the fast process poles. This means that the controller should cancel the fast process poles by controller zeros. Since unstable modes cannot be canceled, the presence of a fast unstable pole implies that the gain crossover frequency must be sufficiently large.

To summarize, we obtain the following simple rule for choosing closed loop poles: slow stable process zeros should be matched by slow closed loop poles, and fast stable process poles should be matched by fast closed loop poles. Slow unstable process zeros and fast unstable process poles impose severe limitations.

### Example 13.10 Nanopositioning system for an atomic force microscope

A simple nanopositioner with the process transfer function

$$P(s) = \frac{\omega_0^2}{s^2 + 2\zeta\omega_0s + \omega_0^2}$$

was explored in Example 10.9. It was shown that the system could be controlled using an integral controller. The closed-loop performance was poor because the gain crossover frequency was limited to  $\omega_{gc} < 2\zeta\omega_0(1 - s_m)$  to have good robustness with the integrating controller. It can be shown that little improvement is obtained by using a PI controller. We will explore if better performance can be obtained with PID control. For a modest performance increase, we will use the design rule derived in Example 13.9 that fast stable process poles should be canceled by controller zeros. The controller transfer function should thus be chosen as

$$C(s) = \frac{k_d s^2 + k_p s + k_i}{s} = \frac{k_i s^2 + 2\zeta\omega_0 s + \omega_0^2}{s \omega_0^2} \quad (13.16)$$

which gives  $k_p = 2\zeta k_i / \omega_0$  and  $k_d = k_i / \omega_0^2$ . The loop transfer function becomes  $L(s) = k_i / s$ .

Figure 13.14 shows, in dashed lines, the gain curves for the Gang of Four for a system designed with  $k_i = 0.5$ . A comparison with Figure 10.12 shows that the bandwidth is increased significantly from  $\omega_{gc} = 0.01$  to  $\omega_{gc} = k_i = 0.5$ . Since

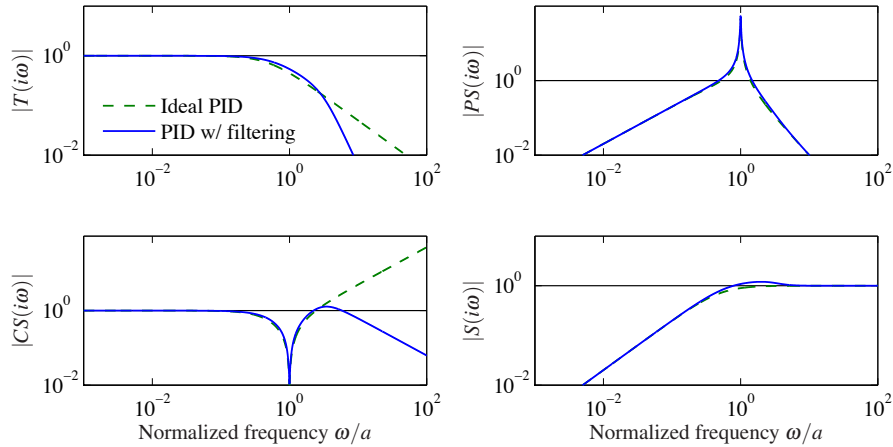

**Figure 13.14:** Nanopositioning system control via cancellation of the fast process pole. Gain plots for the Gang of Four for PID control with second-order filtering (13.17) are shown by solid lines, and the dashed lines show results for an ideal PID controller without filtering (13.16).

the process pole is canceled, the system will, however, still be very sensitive to load disturbances with frequencies close to the resonant frequency. The gain curve of  $CS$  has a dip or a notch at the resonant frequency  $\omega_0$ , which implies that the controller gain is very low for frequencies around the resonance. The gain curve also shows that the system is very sensitive to high-frequency noise. The system will likely be unusable because the gain goes to infinity for high frequencies.

The sensitivity to high frequency noise can be remedied by modifying the controller to be

$$C(s) = \frac{k_i}{s} \frac{s^2 + 2\zeta\omega_0s + \omega_0^2}{a^2(1 + sT_f + (sT_f)^2/2)}, \quad (13.17)$$

which has high-frequency roll-off. Selection of the constant  $T_f$  for the filter is a compromise between attenuation of high-frequency measurement noise and robustness. A large value of  $T_f$  reduces the effects of sensor noise significantly, but it also reduces the stability margin. Since the gain crossover frequency without filtering is  $k_i$ , a reasonable choice is  $T_f = 0.2/k_i$ , as shown by the solid curves in Figure 13.14. The plots of  $|CS(i\omega)|$  and  $|S(i\omega)|$  show that the sensitivity to high-frequency measurement noise is reduced dramatically at the cost of a marginal increase of sensitivity. Notice that the poor attenuation of disturbances with frequencies close to the resonance is not visible in the sensitivity function because of the cancellation of the resonant poles.

The designs thus far have the drawback that load disturbances with frequencies close to the resonance are not attenuated, since  $|S(i\omega_0)|$  is close to one. We will now consider a design that actively attenuates the poorly damped modes. We start with an ideal PID controller where the design can be done analytically, and we add

high-frequency roll-off. The loop transfer function obtained with this controller is

$$L(s) = \frac{a^2(k_d s^2 + k_p s + k_i)}{s(s^2 + 2\zeta a s + a^2)}. \quad (13.18)$$

The closed loop system is of third order, and its characteristic polynomial is

$$s^3 + (k_d a^2 + 2\zeta a)s^2 + (k_p + 1)a^2 s + k_i a^2. \quad (13.19)$$

A general third-order polynomial can be parameterized as

$$s^3 + (\alpha_c + 2\zeta_c)\omega_c s^2 + (1 + 2\alpha_c \zeta_c)\omega_c^2 s + \alpha_c \omega_c^3. \quad (13.20)$$

The parameters  $\alpha_c$  and  $\zeta_c$  give the relative configuration of the poles, and the parameter  $\omega_c$  gives their magnitudes, and therefore also the bandwidth of the system.

The identification of coefficients of equal powers of  $s$  with equation (13.19) gives a linear equation for the controller parameters, which has the solution

$$k_p = \frac{(1 + 2\alpha_c \zeta_c)\omega_c^2}{a^2} - 1, \quad k_i = \frac{\alpha_c \omega_c^3}{\omega_0^2}, \quad k_d = \frac{(\alpha_c + 2\zeta_c)\omega_c}{a^2} - \frac{2\zeta_c}{\omega_0}. \quad (13.21)$$

To obtain a design with active damping, the closed loop bandwidth  $\omega_c$  should be at least as fast as the resonant mode  $\omega_0$ . Adding high-frequency roll-off, the controller becomes

$$C(s) = \frac{k_d s^2 + k_p s + k}{s(1 + sT_f + (sT_f)^2/2)}. \quad (13.22)$$

The value  $T_f = T_d/10 = 0.1 k_d/k$  is a reasonable value for the filtering time constant, larger values give better damping but less robustness.

Figure 13.15 shows the gain curves of the Gang of Four for designs with  $\zeta_c = 0.707$ ,  $\alpha_c = 1$  and  $\omega_c = \omega_0, 2\omega_0$  and  $4\omega_0$ . The figure shows that the largest values of the sensitivity function and the complementary sensitivity function are small. The gain curve for *PS* shows that the load disturbances are now well attenuated over the whole frequency range, and attenuation increases with increasing  $\omega_0$ . The gain curve for *CS* shows that large control signals are required to provide active damping. The high gain of *CS* for high frequencies also shows that low-noise sensors and actuators with a wide range are required. The largest gains for *CS* are 19, 103 and 434 for  $\omega_0 = a, 2a$  and  $4a$ , respectively. There is clearly a trade-off between disturbance attenuation and controller gain. A comparison of Figures 13.14 and 13.15 illustrates the trade-offs between control action and disturbance attenuation for the designs with cancellation of the fast process pole and active damping.  $\nabla$



### 13.5 Design for Robust Performance

Control design is a rich problem where many factors have to be taken into account. Typical requirements are that load disturbances should be attenuated, the controller

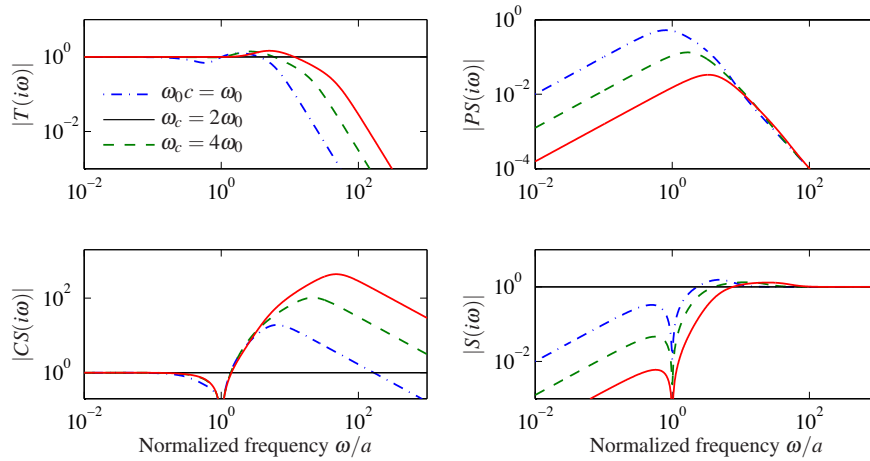

**Figure 13.15:** Nanopositioner control using active damping. Gain curves for the Gang of Four for PID control of the nanopositioner designed for  $\omega_c = \omega_0$  (dash-dotted),  $2\omega_0$  (dashed), and  $4\omega_0$  (solid). The controller has high-frequency roll-off and has been designed to give active damping of the oscillatory mode. The different curves correspond to different choices of magnitudes of the poles, parameterized by  $\omega_c$  in equation (13.19).

should inject only a moderate amount of measurement noise, the output should follow variations in the command signal well and the closed loop system should be insensitive to process variations. For the system in Figure 13.9 these requirements can be captured by specifications on the sensitivity functions  $S$  and  $T$  and the transfer functions  $G_{yv}$ ,  $G_{uw}$ ,  $G_{yr}$  and  $G_{ur}$ . Notice that it is necessary to consider at least seven transfer functions, as discussed Section 12.1. The requirements are mutually conflicting, and may be necessary to make trade-offs. The attenuation of load disturbances will be improved if the bandwidth is increased, but so will the noise injection.

It is highly desirable to have design methods that can guarantee robust performance. Such design methods did not appear until the late 1980s. Many of these design methods result in controllers having the same structure as the controller based on state feedback and an observer. In this section we provide a brief review of some of the techniques as a preview for those interested in more specialized study.

### Quantitative Feedback Theory

*Quantitative feedback theory* (QFT) is a graphical design method for robust loop shaping that was developed by I. M. Horowitz [Hor91]. The idea is to first determine a controller that gives a complementary sensitivity that is robust to process variations and then to shape the response to reference signals by feedforward. The idea is illustrated in Figure 13.16a, which shows the level curves of the gain  $|T(i\omega)|$  of the complementary sensitivity function on a Nyquist plot. The complementary sensitivity function has unit gain on the line  $\text{Re}L(i\omega) = -0.5$ . In the

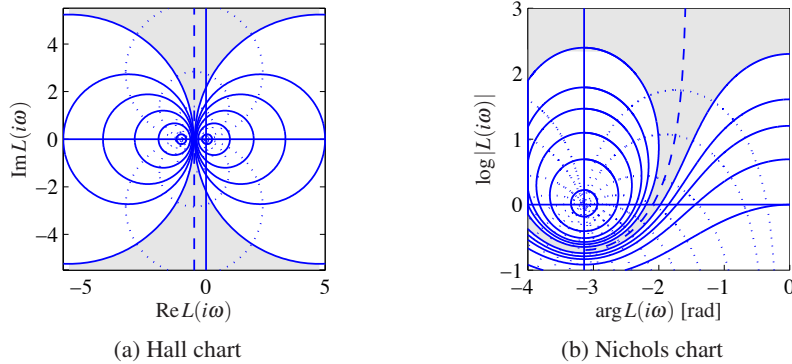

**Figure 13.16:** Hall and Nichols charts. The Hall chart is a Nyquist plot with curves for constant gain and phase of the complementary sensitivity function  $T$ . The Nichols chart is the conformal map of the Hall chart under the transformation  $N = \log L$  (with the scale flipped). The dashed curve is the line where  $|T(i\omega)| = 1$ , and the shaded region corresponding to loop transfer functions whose complementary sensitivity changes by no more than  $\pm 10\%$  is shaded.

neighborhood of this line, significant variations in process dynamics only give moderate changes in the complementary transfer function. The shaded part of the figure corresponds to the region  $0.9 < |T(i\omega)| < 1.1$ . To use the design method, we represent the uncertainty for each frequency by a region and attempt to shape the loop transfer function so that the variation in  $T$  is as small as possible. The design is often performed using the Nichols chart shown in Figure 13.16b.

### Linear Quadratic Control

One way to make the trade-off between the attenuation of load disturbances and the injection of measurement noise is to design a controller that minimizes the loss function

$$J = \int_0^{\infty} (y^2(t) + \rho u^2(t)) dt,$$

where  $\rho$  is a weighting parameter as discussed in Section 7.3. This loss function gives a compromise between load disturbance attenuation and disturbance injection because it balances control actions against deviations in the output. If all state variables are measured, the controller is a state feedback  $u = -Kx$  and it has the same form as the controller obtained by eigenvalue assignment (pole placement) in Section 7.2. However, the controller gain is obtained by solving an optimization problem. It has been shown that this controller is very robust. It has a phase margin of at least  $60^\circ$  and an infinite gain margin. The controller is called a *linear quadratic control* or *LQ control* because the process model is linear and the criterion is quadratic.

When all state variables are not measured, the state can be reconstructed using an observer, as discussed in Section 8.3. It is also possible to introduce process disturbances and measurement noise explicitly in the model and to reconstruct



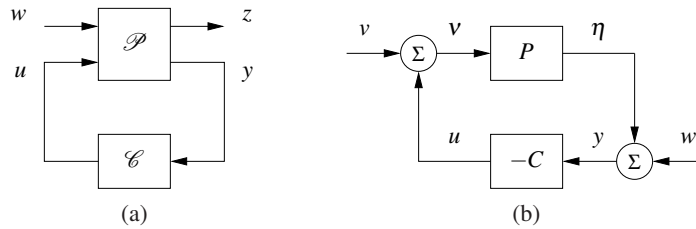

**Figure 13.17:**  $H_\infty$  robust control formulation. (a) General representation of a control problem used in robust control. The input  $u$  represents the control signal, the input  $w$  represents the external influences on the system, the output  $z$  is the generalized error and the output  $y$  is the measured signal. (b) Special case of the basic feedback loop in Figure 13.9 where the reference signal is zero. In this case we have  $w = (n, d)$  and  $z = (y, -u)$ .

the states using a Kalman filter, as discussed briefly in Section 8.4. The Kalman filter has the same structure as the observer designed by eigenvalue assignment in Section 8.3, but the observer gains  $L$  are now obtained by solving an optimization problem. The control law obtained by combining linear quadratic control with a Kalman filter is called *linear quadratic Gaussian control* or *LQG control*. The Kalman filter is optimal when the models for load disturbances and measurement noise are Gaussian.

It is interesting that the solution to the optimization problem leads to a controller having the structure of a state feedback and an observer. The state feedback gains depend on the parameter  $\rho$ , and the filter gains depend on the parameters in the model that characterize process noise and measurement noise (see Section 8.4). There are efficient programs to compute these feedback and observer gains.

The nice robustness properties of state feedback are unfortunately lost when the observer is added. There are parameters that give closed loop systems with poor robustness, similar to Example 13.8. We can thus conclude that there is a fundamental difference between using sensors for all states and reconstructing the states using an observer.

### $H_\infty$ Control



Robust control design is often called  $H_\infty$  control for reasons that will be explained shortly. The basic ideas are simple, but the details are complicated and we will therefore just give the flavor of the results. A key idea is illustrated in Figure 13.17a, where the closed loop system is represented by two blocks, the process  $\mathcal{P}$  and the controller  $\mathcal{C}$  as discussed in Section 12.1. The process  $\mathcal{P}$  has two inputs, the control signal  $u$ , which can be manipulated by the controller, and the generalized disturbance  $w$ , which represents all external influences, e.g., command signals and disturbances. The process has two outputs, the generalized error  $z$ , which is a vector of error signals representing the deviation of signals from their desired values, and the measured signal  $y$ , which can be used by the controller to compute  $u$ . For a linear system and a linear controller the closed loop system can be represented

by the linear system

$$z = H(P(s), C(s))w, \quad (13.23)$$

which tells how the generalized error  $z$  depends on the generalized disturbances  $w$ . The control design problem is to find a controller  $C$  such that the gain of the transfer function  $H$  is small even when the process has uncertainties. There are many different ways to specify uncertainty and gain, giving rise to different designs. The names  $H_2$  and  $H_\infty$  control correspond to the norms  $\|H\|_2$  and  $\|H\|_\infty$ .

To illustrate the ideas we will consider a regulation problem for a system where the reference signal is assumed to be zero and the external signals are the load disturbance  $v$  and the measurement noise  $w$ , as shown in Figure 13.17b. The generalized input is  $w = (-n, d)$ . (The negative sign of  $w$  is not essential but is chosen to obtain somewhat nicer equations.) The generalized error is chosen as  $z = (\eta, v)$ , where  $\eta$  is the process output and  $v$  is the part of the load disturbance that is not compensated by the controller. The closed loop system is thus modeled by

$$z = \begin{pmatrix} y \\ -u \end{pmatrix} = \begin{pmatrix} \frac{1}{1+PC} & \frac{P}{1+PC} \\ C & PC \\ \frac{1}{1+PC} & \frac{1}{1+PC} \end{pmatrix} \begin{pmatrix} w \\ v \end{pmatrix} = H(P, C) \begin{pmatrix} w \\ v \end{pmatrix}, \quad (13.24)$$

which is the same as equation (13.23). A straightforward calculation shows that

$$\|H(P, C)\|_\infty = \sup_{\omega} \frac{\sqrt{(1 + |P(i\omega)|^2)(1 + |C(i\omega)|^2)}}{|1 + P(i\omega)C(i\omega)|}. \quad (13.25)$$

There are numerical methods for finding a stabilizing controller such that  $\|H(P, C)\|_\infty < \gamma$ , if such a controller exists. The best controller can then be found by iterating on  $\gamma$ . The calculations can be made by solving *algebraic Riccati* equations, e.g., by using the command `hinfsyn` in MATLAB. The controller has the same order as the process and the same structure as the controller based on state feedback and an observer; see Figure 8.7 and Theorem 8.3.

Notice that if we minimize  $\|H(P, C)\|_\infty$ , we make sure that the transfer functions  $G_{yv} = P/(1 + PC)$ , representing the transmission of load disturbances to the output, and  $G_{uw} = -C/(1 + PC)$ , representing how measurement noise is transmitted to the control signal, are small. Since the sensitivity and the complementary sensitivity functions are also elements of  $H(P, C)$ , we have also guaranteed that the sensitivities are less than  $\gamma$ . The design methods thus balance performance and robustness.

There are strong robustness results associated with the  $H_\infty$  controller. It follows from equations (13.4) and (13.25) that

$$\|H(P, C)\|_\infty = \frac{1}{\delta_v(P, -1/C)}. \quad (13.26)$$

The inverse of  $\|H(P, C)\|_\infty$  is thus equal to the Vinnicombe distance between  $P$  and  $-1/C$  and can therefore be interpreted as a *generalized stability margin*. Compare

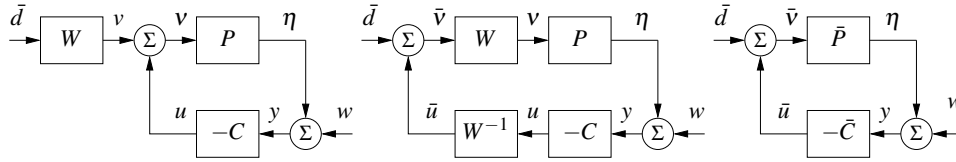

**Figure 13.18:** Block diagrams of a system with disturbance weighting. The left figure provides a frequency weight on processes disturbances. Through block diagram manipulation, this can be converted to the standard problem on the right.

this with  $s_m$ , which we defined as the shortest distance between the Nyquist curve of the loop transfer function and the critical point  $-1$ . It also follows that if we find a controller  $C$  with  $\|H(P, C)\|_\infty < \gamma$ , then this controller will stabilize any process  $P_*$  such that  $\delta_v(P, P_*) < 1/\gamma$ .

### Disturbance Weighting

Minimizing the gain  $\|H(P, C)\|_\infty$  means that the gains of all individual signal transmissions from disturbances to outputs are less than  $\gamma$  for all frequencies of the input signals. The assumption that the disturbances are equally important and that all frequencies are also equally important is not very realistic; recall that load disturbances typically have low frequencies and measurement noise is typically dominated by high frequencies. It is straightforward to modify the problem so that disturbances of different frequencies are given different emphasis, by introducing a weighting filter on the load disturbance as shown in Figure 13.18. For example, low-frequency load disturbances will be enhanced by choosing  $W$  as a low-pass filter because the actual load disturbance is  $W\bar{d}$ .

By using block diagram manipulation as shown in Figure 13.18, we find that the system with frequency weighting is equivalent to the system with no frequency weighting in Figure 13.18 and the signals are related through

$$\bar{z} = \begin{pmatrix} y \\ \bar{u} \end{pmatrix} \begin{pmatrix} \frac{1}{1 + \bar{P}\bar{C}} & \frac{\bar{P}}{1 + \bar{P}\bar{C}} \\ \bar{C} & \bar{P}\bar{C} \\ \frac{1}{1 + \bar{P}\bar{C}} & \frac{1}{1 + \bar{P}\bar{C}} \end{pmatrix} \begin{pmatrix} w \\ \bar{v} \end{pmatrix} = H(\bar{P}, \bar{C})\bar{w}, \quad (13.27)$$

where  $\bar{P} = PW$  and  $\bar{C} = W^{-1}C$ . The problem of finding a controller  $\bar{C}$  that minimizes the gain of  $H(\bar{P}, \bar{C})$  is thus equivalent to the problem without disturbance weighting; having obtained  $\bar{C}$ , the controller for the original system is then  $C = W\bar{C}$ . Notice that if we introduce the frequency weighting  $W = k/s$ , we will automatically get a controller with integral action.

### Limits of Robust Design

There is a limit to what can be achieved by robust design. In spite of the nice properties of feedback, there are situations where the process variations are so large

that it is not possible to find a linear controller that gives a robust system with good performance. It is then necessary to use other types of controllers. In some cases it is possible to measure a variable that is well correlated with the process variations. Controllers for different parameter values can then be designed and the corresponding controller can be chosen based on the measured signal. This type of control design is called *gain scheduling*. The cruise controller is a typical example where the measured signal could be gear position and velocity. Gain scheduling is the common solution for high-performance aircraft where scheduling is done based on Mach number and dynamic pressure. When using gain scheduling, it is important to make sure that switches between the controllers do not create undesirable transients (often referred to as *bumpless transfer*).

If it is not possible to measure variables related to the parameters, *automatic tuning* and *adaptive control* can be used. In automatic tuning the process dynamics are measured by perturbing the system, and a controller is then designed automatically. Automatic tuning requires that parameters remain constant, and it has been widely applied for PID control. It is a reasonable guess that in the future many controllers will have features for automatic tuning. If parameters are changing, it is possible to use adaptive methods where process dynamics are measured online.

### 13.6 Further Reading

The topic of robust control is a large one, with many articles and textbooks devoted to the subject. Robustness was a central issue in classical control as described in Bode's classical book [Bod45]. Robustness was deemphasized in the euphoria of the development of design methods based on optimization. The strong robustness of controllers based on state feedback, shown by Anderson and Moore [AM90], contributed to the optimism. The poor robustness of output feedback was pointed out by Rosenbrock [RM71], Horowitz [Hor75] and Doyle [Doy78] and resulted in a renewed interest in robustness. A major step forward was the development of design methods where robustness was explicitly taken into account, such as the seminal work of Zames [Zam81]. Robust control was originally developed using powerful results from the theory of complex variables, which gave controllers of high order. A major breakthrough was made by Doyle, Glover, Khar-gonekar and Francis [DGKF89], who showed that the solution to the problem could be obtained using Riccati equations and that a controller of low order could be found. This paper led to an extensive treatment of  $H_\infty$  control, including books by Francis [Fra87], McFarlane and Glover [MG90], Doyle, Francis and Tannenbaum [DFT92], Green and Limebeer [GL95], Zhou, Doyle and Glover [ZDG96], Skogestad and Postlethwaite [SP05] and Vinnicombe [Vin01]. A major advantage of the theory is that it combines much of the intuition from servomechanism theory with sound numerical algorithms based on numerical linear algebra and optimization. The results have been extended to nonlinear systems by treating the design problem as a game where the disturbances are generated by an adversary, as described in the book by Basar and Bernhard [BB91]. Gain scheduling and

adaptation are discussed in the book by Åström and Wittenmark [ÅW08].

### Exercises

**13.1** Consider systems with the transfer functions  $P_1 = 1/(s+1)$  and  $P_2 = 1/(s+a)$ . Show that  $P_1$  can be changed continuously to  $P_2$  with bounded additive and multiplicative uncertainty if  $a > 0$  but not if  $a < 0$ . Also show that no restriction on  $a$  is required for feedback uncertainty.

**13.2** Consider systems with the transfer functions  $P_1 = (s+1)/(s+1)^2$  and  $P_2 = (s+a)/(s+1)^2$ . Show that  $P_1$  can be changed continuously to  $P_2$  with bounded feedback uncertainty if  $a > 0$  but not if  $a < 0$ . Also show that no restriction on  $a$  is required for additive and multiplicative uncertainties.

**13.3** (Difference in sensitivity functions) Let  $T(P, C)$  be the complementary sensitivity function for a system with process  $P$  and controller  $C$ . Show that

$$T(P_1, C) - T(P_2, C) = \frac{(P_1 - P_2)C}{(1 + P_1C)(1 + P_2C)},$$

and derive a similar formula for the sensitivity function.

**13.4** (The Riemann sphere) Consider systems with the transfer functions  $P_1 = k/(s+1)$  and  $P_2 = k/(s-1)$ . Show that 

$$d(P_1, P_2) = \frac{2k}{1+k^2}, \quad \delta_v(P_1, P_2) = \begin{cases} 1, & \text{if } k < 1 \\ \frac{2k}{1+k^2} & \text{otherwise.} \end{cases}$$

Use the Riemann sphere to show geometrically that  $\delta_v(P_1, P_2) = 1$  if  $k < 1$ . (Hint: It is sufficient to evaluate the transfer function for  $\omega = 0$ .)

**13.5** (Stability margins) Consider a feedback loop with a process and a controller having transfer functions  $P$  and  $C$ . Assume that the maximum sensitivity is  $M_s = 2$ . Show that the phase margin is at least  $30^\circ$  and that the closed loop system will be stable if the gain is changed by 50%.

**13.6** (Bode's ideal loop transfer function) Make Bode and Nyquist plots of Bode's ideal loop transfer function. Show that the phase margin is  $\phi_m = 180^\circ - 90^\circ n$  and that the stability margin is  $s_m = \arcsin \pi(1 - n/2)$ .

**13.7** Consider a process with the transfer function  $P(s) = k/(s(s+1))$ , where the gain can vary between 0.1 and 10. A controller that is robust to these gain variations can be obtained by finding a controller that gives the loop transfer function  $L(s) = 1/(s\sqrt{s})$ . Suggest how the transfer function can be implemented by approximating it by a rational function.

**13.8** (Smith predictor) The *Smith predictor*, a controller for systems with time delays, is a special version of Figure 13.8a with  $P(s) = e^{-s\tau}P_0(s)$  and  $C(s) =$

$C_0(s)/(1 + C_0(s)P(s))$ . The controller  $C_0(s)$  is designed to give good performance for the process  $P_0(s)$ . Show that the sensitivity functions are

$$S(s) = \frac{1 + (1 - e^{-s\tau})P_0(s)C_0(s)}{1 + P_0(s)C_0(s)}, \quad T(s) = \frac{P_0(s)C_0(s)}{1 + P_0(s)C_0(s)} e^{-s\tau}.$$

**13.9** (Ideal delay compensator) Consider a process whose dynamics are a pure time delay with transfer function  $P(s) = e^{-s}$ . The ideal delay compensator is a controller with the transfer function  $C(s) = 1/(1 - e^{-s})$ . Show that the sensitivity functions are  $T(s) = e^{-s}$  and  $S(s) = 1 - e^{-s}$  and that the closed loop system will be unstable for arbitrarily small changes in the delay.

**13.10** (Vehicle steering) Consider the Nyquist curve in Figure 13.11. Explain why part of the curve is approximately a circle. Derive a formula for the center and the radius and compare with the actual Nyquist curve.

**13.11** Consider a process with the transfer function

$$P(s) = \frac{(s+3)(s+200)}{(s+1)(s^2+10s+40)(s+40)}.$$

Discuss suitable choices of closed loop poles for a design that gives dominant poles with undamped natural frequency 1 and 10.

**13.12** (AFM nan positioning system) Consider the design in Example 13.10 and explore the effects of changing parameters  $\alpha_0$  and  $\zeta_0$ .

**13.13** ( $H_\infty$  control) Consider the matrix  $H(P, C)$  in equation (13.24). Show that it has the singular values

$$\sigma_1 = 0, \quad \sigma_2 = \bar{\sigma} = \sup_{\omega} \frac{\sqrt{(1 + |P(i\omega)|^2)(1 + |C(i\omega)|^2)}}{|1 + P(i\omega)C(i\omega)|} = \|H(P, C)\|_\infty.$$

Also show that  $\bar{\sigma} = 1/d_v(P, -1/C)$ , which implies that  $1/\bar{\sigma}$  is a generalization of the closest distance of the Nyquist plot to the critical point.

**13.14** Show that

$$\delta_v(P, -1/C) = \inf_{\omega} \frac{|P(i\omega) + 1/C(i\omega)|}{\sqrt{(1 + |P(i\omega)|^2)(1 + 1/|C(i\omega)|^2)}} = \frac{1}{\|H(P, C)\|_\infty}.$$

**13.15** Consider the system

$$\frac{dx}{dt} = Ax + Bu = \begin{pmatrix} -1 & 0 \\ 1 & 0 \end{pmatrix} x + \begin{pmatrix} a-1 \\ 1 \end{pmatrix} u, \quad y = Cx = \begin{pmatrix} 0 & 1 \end{pmatrix} y.$$

Design a state feedback that gives  $\det(sI - BK) = s^2 + 2\zeta_c\omega_c s + \omega_c^2$ , and an observer with  $\det(sI - LC) = s^2 + 2\zeta_o\omega_o s + \omega_o^2$  and combine them using the separation principle to get an output feedback. Choose the numerical values  $a = 1.5$ ,  $\omega_c = 5$ ,  $\zeta_c = 0.6$  and  $\omega_o = 10$ ,  $\zeta_o = 0.6$ . Compute the eigenvalues of the perturbed

system when the process gain is increased by 2%. Also compute the loop transfer function and the sensitivity functions. Is there a way to know beforehand that the system will be highly sensitive?

**13.16** (Robustness using the Nyquist criterion) Another view of robust performance can be obtained through appeal to the Nyquist criterion. Let  $S_{\max}(i\omega)$  represent a desired upper bound on our sensitivity function. Show that the system provides this level of performance subject to additive uncertainty  $\Delta$  if the following inequality is satisfied:

$$|1 + \tilde{L}| = |1 + L + C\Delta| > \frac{1}{|S_{\max}(i\omega)|} \quad \text{for all } \omega \geq 0. \quad (13.28)$$

Describe how to check this condition using a Nyquist plot.





---

## Chapter Fourteen

### Architecture and Design

*A doctor can bury his mistakes, but an architect can only advise his clients to plant vines.*

Frank Lloyd Wright

In this chapter we will put the simple feedback loops into the context of real control systems systems. We will illustrate what control systems look like and how they are designed. Some important observations are that real control systems combine “continuous time feedback” with “discrete elements” such as logic and finite state machines and that they interact with humans. Design of safe systems is an important issue which relates to requirements, modeling, design, verification, implementation commissioning, operation and upgrading (in short systems engineering). Think about different names and how to squeeze this into 25 pages.

#### 14.1 Bottom-Up Architectures

The idea of building control systems bottom up by a loop-by-loop design emerged in the process industry, originally only a few loops were used but as systems and ambitions grew the approach was extended, today it is used in large control systems with many thousand loops. The elements used to build the control systems are controllers (often PID), filters, and nonlinear elements. The components can either be separate pieces of hardware or function blocks implemented in software that can be combined graphically in distributed control systems using cut and paste. The system is built loop by loop by combining control principles such as feedback and feedforward, which have been discussed extensively in Chapters ?? and ?? in simple architectures. There are many other architectural structures (control principles) such as *cascade control*, *mid-range control*, *selector control* and *repetitive control*, *model following*, *gain scheduling*, *adaptation* and *extremal control* which will be discussed in this section. An advantage with the bottom-up approach is that the system can be commissioned and tuned loop by loop. There may be difficulties when the loops are interacting. The disadvantage is that it is not easy to judge if additional loops will bring benefits. The system can also be unwieldy when loops are added.

#### Interaction

A drawback with the bottom up approach when the system is built loop by loop is that there may be unintended interactions. It is therefore important to investigate

when interactions. We will start by investigating a system with two inputs and two outputs, let the transfer function and its inverse be

$$P(s) = \begin{pmatrix} P_{11}(s) & P_{12}(s) \\ P_{21}(s) & P_{22}(s) \end{pmatrix}, \quad P^{-1}(s) = \frac{1}{\det P(s)} \begin{pmatrix} P_{11}(s) & -P_{21}(s) \\ -P_{12}(s) & P_{22}(s) \end{pmatrix}, \quad (14.1)$$

where  $\det P(s) = P_{11}(s)P_{22}(s) - P_{12}(s)P_{21}(s)$ . Assume that we want to control the system by two single loop controllers. The first problem is to decide if  $y_1$  should be controlled by  $u_1$  or  $u_2$ , this is called the *pairing problem* and the second problem is to investigate if there will be interactions between the loops. Sometimes the solution to the problem is clear from the physics of the process. The problem can be resolved by trial and error: design controller for the different alternatives and explore their properties.

A clever idea that gives a lot of insight with modest calculations was proposed by Bristol. Assume for simplicity that we are exploring the possibility of controlling  $y_1$  by  $u_1$  and  $y_2$  by  $u_2$ . Controllers can be designed based on the transfer functions  $P_{11}(s)$  and  $P_{22}(s)$ . The controller for the first loop will then work well if the second loop is open but the question is how the second loop will influence the second loop. Bristol proposed to look at the ratio

$$\lambda(s) = \frac{P_{11}(s)}{\bar{P}_{11}(s)}, \quad (14.2)$$

where  $\bar{P}_{11}(s)$  is the transfer function from  $u_1$  to  $y_1$  when the *perfectly controlled* meaning  $y_2 = 0$ . Assuming all signals are exponential functions we have for perfect control of the second loop

$$y_1 = P_{11}u_1 + P_{12}u_2, \quad 0 = P_{21}u_1 + P_{22}u_2, \quad y_1, u_1, u_2 \in \mathcal{E}.$$

Eliminating  $u_2$  in these equations give

$$y_1 = \frac{P_{11}P_{22} - P_{12}P_{21}}{P_{22}}u_1,$$

and we find

$$\bar{P}_{11} = \frac{P_{11}P_{22} - P_{12}P_{21}}{P_{22}}, \quad \text{and} \quad \lambda = \frac{P_{11}P_{22}}{\det P}. \quad (14.3)$$

If  $|\lambda(i\omega)| > 1$  is larger than one the interaction increases the gain and it decreases the gain if  $|\lambda(i\omega)| < 1$ . There is no interaction if  $\lambda(s) = 0$ , neither if  $\lambda(s) = 1$  but the loops should then be reversed so that  $y_1$  is controlled by  $u_2$ . There are rules of thumb for interpreting the relative gain array, interactions can typically be neglected for  $3/4 < |\lambda(i\omega)| < 3/2$ , which means the controller must then be designed to cope with an additive process uncertainty such that  $|\Delta/P| < 1/3$ , see Figure 13.2. Decoupling or multivariable control should be considered outside this range.

It follows from (14.1) that  $\lambda(s)$  is the product of the 11 elements of  $P$  and  $P^{-1}$  it turns out that the analysis can be generalized to systems with  $n$  inputs and  $n$

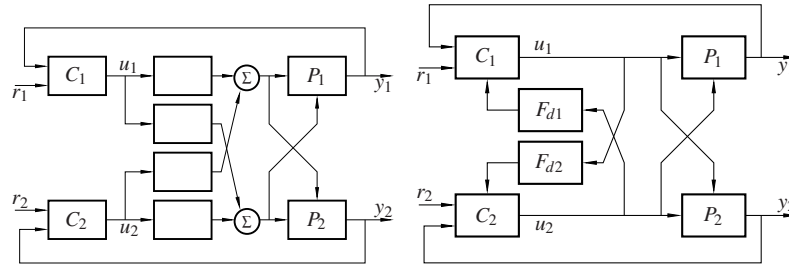

**Figure 14.1:** Decoupling, (a) direct decoupling and (b) feedback decoupling.

outputs and the interactions can then be characterized by the matrix

$$\Lambda(s) = P(s) \circ P^{-T}(s) = P(s) \cdot * P^{-T}(s) \quad (14.4)$$

where  $P^{-T}(s)$  denotes the transpose of  $P^{-1}(s)$  and  $\circ$  denotes element by element multiplication of matrices (Hadamard product). The matrix  $\Lambda(s)$ , which was originally derived for the steady state case ( $s = 0$ ) is called *the relative gain array (RGA)* or *Bristol's RGA*, it was later extended to dynamics.

The relative gain array has the nice property that it is dimension free and that it gives insight into interactions and pairing of variables, by analysing the gain  $|\Lambda(i\omega)|$  we also get insight into interactions at different frequencies. The RGA also gives information about the variables that should be grouped for multivariable control, see [?].

## Decoupling

Decoupling is one way to deal to reduce the interactions between the loops. The idea is to provide the controller with a compensator which reduces the interactions. Two ways of making decoupling; direct decoupling and feedback decoupling are illustrated in Figure 14.1. In *direct decoupling* the controller is provided with a post compensator that reduces the effects of the interactions. To design a controller that reduces the effects of the interaction. In *feedback decoupling* the compensation is instead arranged by feeding the output of one controller to the other controller and vice versa. The expression for the compensator for direct decoupling is a complicated expression in the process transfer function. The corresponding expressions for feedback decoupling are much simpler. If the process transfer function is given by (??) it becomes

$$F_{d1} = -P_{11}^{-1}P_{12}, \quad F_{d2} = -P_{22}^{-1}P_{21}.$$

Feedback decoupling has another advantage. Since the controllers  $C_1$  and  $C_2$  act directly on the actuators a conventional anti-windup scheme will work provided that the cross-coupling signals are entered as feedforward signals in the controllers.

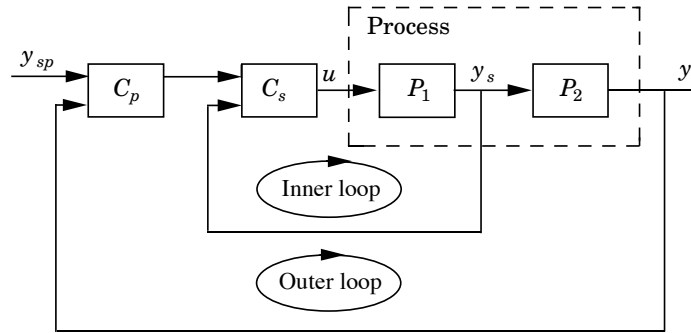

**Figure 14.2:** Block diagram of a system with cascade control. The system has one control variable  $u$  and two measured signals: the primary output  $y$  and the secondary or auxiliary output  $y_s$ .

### Cascade Control

Cascade control can be used when there is one control signal and several measurement signals. The block diagram in Figure 14.2 is an example. The system in the figure has two loops. The inner loop is called *the secondary loop* and the outer loop is called *the primary loop*. The reason for this terminology is that the outer loop deals with the primary measured signal. It is also possible to have a cascade control with more nested loops. The ultimate case is state feedback when all states are measured. Cascade control was used in XXX where it was called inner-outer loop design.

Cascade control is useful in when there is significant time delay or dynamics between the input  $u$  and the primary output  $y$ , but significantly less dynamics between  $u$  and the secondary output  $y_s$ , and when the major disturbances enter in the block  $P_1$ . Cascade control then admits tight feedback in the inner loop, which reduces the effect of disturbances acting on  $P_1$ . The benefits of cascade control are illustrated by an example.

#### Example 14.1 Improved Load Disturbance Rejection

Consider the system shown in Figure 14.2 where the process transfer functions are

$$P_1 = \frac{1}{s+1} \quad P_2 = \frac{1}{(s+1)^3}.$$

There are significant dynamics from the control variable  $u$  to the primary output  $y$ , the average residence time is 4 s. However, the secondary output  $y_s$  responds much faster than the primary output, the average residence time is 1 s. Thus, cascade control can be expected to give improvements. A well tuned PI controller without cascade control has the parameters  $k_p = 0.2$  and  $k_i = 0.15$ . The dashed lines in Figure 14.3 show the response to a unit step load disturbance at the process input for this controller. Since the response of the secondary measured variable to the control signal is quite fast, it is possible to use high loop gains in the secondary loop. The responses shown in solid lines Figure 14.3 are obtained. The figure shows

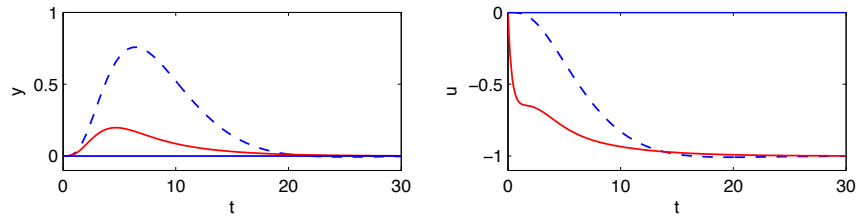

**Figure 14.3:** Responses to a load disturbance for a system with (solid line) and without (dashed line) cascade control. The left plot shows the output and the right plot shows the control signal. The conventional architecture is a PI controller ( $k_p = 0.3$ ,  $k_i = 0.15$  from  $y$  to  $u$ ). The cascade controller has a secondary loop with proportional control with gain  $k_p = 4$  and the outer loop is a PI controller with gains  $k_p = 0.6$  and  $k_i = 0.3$ .

that the disturbance response is improved substantially by using cascade control. Notice in particular that the control variable drops very much faster with cascade control. The main reason for this is the fast inner feedback loop, which detects the disturbance much faster than the outer loop.  $\nabla$

If integral action is used in both the secondary and primary control loops, it is necessary to have a scheme to avoid integral windup. Anti-windup for the secondary controller can be done in the conventional way since the controller drives the actuator directly. To provide anti-windup for the primary controller it must be told when the secondary controller goes into anti-windup mode.

Cascade control is a convenient way to use extra measurements to improve control performance. The following examples illustrate some applications.

#### Example 14.2 Valve Positioners

Control loops with pneumatic valves are a common inprocess control. The control signal drives the valve stem, but the relation between the control signal and the valve opening is corrupted by driving pressure, friction and flow forces on the valve. The effects of these disturbances can be reduced by providing a local controller that adjusts the pressure by feedback from the valve opening.  $\nabla$

#### Parallel Systems

There are situations when several subsystems are used to control the same variable. Typical examples are: temperature control using when several cooling or heating devices and control of an electric car with one motor on each wheel. An extreme example is control of a power grid which may have hundreds of energy sources. Care must be exercised when making loop-by-loop design of such systems. We illustrate by a simple example.

#### Example 14.3 Cruise Control for Electric Car

Consider speed control of an electrical car with motors on each wheel, for simplicity we will consider linear motion with only two motors, and we will use the

simple model (4.1) in Section 4.1. Neglecting all disturbance forces  $F_d$  except the force due to gravity;  $F_r$  the model (4.3) becomes

$$m \frac{dv}{dt} = F_1 + F_2 - mg\theta, \quad (14.5)$$

where  $v$  is the speed of the car,  $\theta$  the slope of the road,  $F_1$  and  $F_2$  the forces generated by the drive motor.

We will first consider the case when both motors have proportional controllers. Let  $v_r$  be the desired (reference) speed, the controllers are then

$$F_1 = k_{p1}(v_r - v), \quad F_2 = k_{p1}(v_r - v), \quad (14.6)$$

Combining equations (??) and (??) gives the following equation for the closed loop system

$$m \frac{dv}{dt} = (k_{p1} + k_{p2})(v_r - v) - mg\theta.$$

If the slope  $\theta$  is constant there will be a steady state error  $e_{ss} = v_r - v_{ss}$  and the steady-state controller outputs are  $u_{1ss} = k_{p1}e_o$  and  $u_{2ss} = k_{p1}e_o$ . The proportional gains  $k_{p1}$  and  $k_{p2}$  thus determine how the *compensation for the disturbance is distributed among the motors*.

Next we will consider the case when each motor is provided by a PI controller. The closed loop system is then described by the equations

$$\begin{aligned} m \frac{dv}{dt} &= (k_{p1} + k_{p2})(v_r - v) + k_{i1}I_1 + k_{i2}I_2 + mg\theta, \\ \frac{dI_1}{dt} &= v_r - v, \quad \frac{dI_2}{dt} = v_r - v \end{aligned} \quad (14.7)$$

This system is not stable, since  $\frac{d(I_1 - I_2)}{dt} = 0$  the system has an eigenvalue at the origin. The system (14.7) has the inputs  $v_r$  and  $\theta$  the output  $y$ , it is of third order. The system has a the Kalman Figure 8.12a, where the reachable and observable subsystem  $\Sigma_{ro}$  which is reachable and observable is of second order. The subsystem  $\Sigma_{\bar{r}\bar{o}}$  is neither reachable nor observable, its dynamics is an integrator and its state can be chosen as  $I_1 - I_2$ .

What happens physically is that if both wheel motors are provided with controllers having controller with integral terms  $I_1$  and  $I_2$  of the controllers will drift in such a way that their sum is constant. As a result one control signal will increase and the other will decrease until saturation occurs. There is a very simple remedy, use one single integrator and distribute the output of that integrator to both motors.

▽

The results of the example can be generalized, if parallel systems are controlled by proportional controllers, then *the controller gains determine how disturbance attenuation is divided among the subsystems*. Moreover, *integral control cannot be used in the individual subsystems*, instead we can select one controller with integral action or we can use *a central integrator* and distribut its output to the controller of the subsystems.

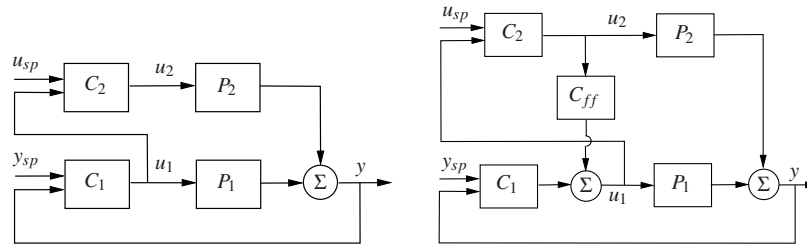

**Figure 14.4:** Block diagram of a two architectures with mid-range control. The system in (a) is the basic architecture and (b) is a refined architecture that also uses feedforward.

### Mid-Range Control

Cascade control is a strategy where there one control signal and several measurement signals are used to meet the control objective. Midranging is an architecture for the dual situation is when many control signals are used to control one measured output. Another view of midranging is that it applies to a special type of parallel systems when one subsystem has a much larger control authority than the other. Consider a system where a single variable  $y$  is controlled using two subsystems with individual control signals  $u_1$  and  $u_2$ . Let the subsystems have transfer functions  $P_1$  and  $P_2$ , and assume that  $P_1$  is fast and accurate but with limited output range (low control authority) and that  $P_2$  which has slow with a wide range (high control authority). A block diagram of the system is shown in Figure ???. A block diagram of the mid-range control strategy is given in Figure 14.4. The controller  $C_1$  which drives  $P_1$  is the primary controller that has that controls the output  $y$  to its desired reference  $r_1$ . The second controller  $C_2$  drives the subsystem  $P_2$  which has large range. The measured signal to  $C_2$  is the input  $u_1$  to the subsystem  $P_2$ , and the controller  $C_2$  attempts to keep the variable  $u_1$  in its mid range. Suppose that the signal  $u_1$  is in the middle of its operating range and that only small disturbances are acting on the system. In this case, the controller  $C_1$  manipulates  $u_1$  to reduce the disturbance. For large disturbances,  $u_1$  may reach approach its limit, the controller  $C_2$  then acts to assist in reducing the disturbances.

The block diagram in Figure ??b is an improvement of the basic mid-range control architecture. The output of the controller  $C_2$  is fed as a feedforward signal to the controller  $C_1$ . The feedforward transfer function is

$$G_{ff}(s) = -\frac{P_2(s)}{P_1(s)}.$$

Conventional anti-windup protection can be used in both controllers in Figure ??a but in the advanced scheme in Figure ??b the feedforward signal is fed into the feedforward summation point in the controller  $C_1$  to avoid windup of the controller.

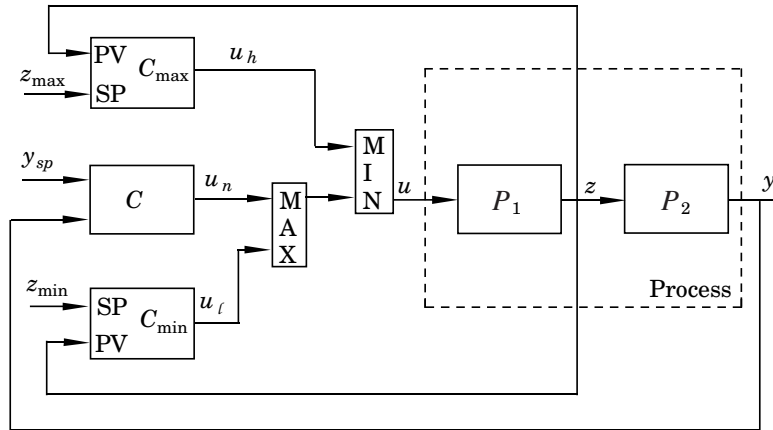

**Figure 14.5:** Block diagram of a system with selector control. The primary controller is  $C$  which attempts to keep  $y$  close to its reference value. The controllers  $C_{max}$  and  $C_{min}$  switches control objective when the variable  $z$  is outside its permissible range..

### Selector Control

There are situations where several controlled process variables must be taken into account. One variable is the primary controlled variable, but for equipment protection it is required that other process variables remain within given ranges. Selector control can be used to achieve this.

A selector is a static device with many inputs and one output. There are two types of selectors: *maximum* and *minimum*. For a maximum selector the output is the largest of the input signals. The idea of selector control is to use several controllers and to have a selector that chooses the controller that is most appropriate. One example of use is where the primary controlled variable is temperature and we must ensure that pressure does not exceed a certain range for safety reasons, another is compressor control where the objective is to maintain a pressure while avoiding compressor surge.

The selector control architecture is illustrated in Figure 14.5. The primary controlled variable is the process output  $y$ . There is an auxiliary measured variable  $z$  that should be kept within the limits  $z_{min}$  and  $z_{max}$ . The primary controller  $C$  has process variable  $y$ , set point  $y_{sp}$ , and output  $u_n$ . There are also secondary controllers with measured process variables that are the auxiliary variable  $z$  and with set points that are bounds of the variable  $z$ . The outputs of these controllers are  $u_h$  and  $u_l$ . The controller  $C$  is an ordinary PI or PID controller that gives good control under normal circumstances. The output of the minimum selector is the smallest of the input signals; the output of the maximum selector is the largest of the inputs.

Under normal circumstances the auxiliary variable is larger than the minimum value  $z_{min}$  and smaller than the maximum value  $z_{max}$ . This means that the output  $u_h$  is large and the output  $u_l$  is small. The maximum selector, therefore, selects  $u_n$ , and the minimum selector also selects  $u_n$ . The system acts as if the maximum and



minimum controller were not present. If the variable  $z$  reaches its upper limit, the variable  $u_h$  becomes small and is selected by the minimum selector. This means that the control system now attempts to control the variable  $z$  and drive it towards its limit. A similar situation occurs if the variable  $z$  becomes smaller than  $z_{\min}$ .

In a system with selectors, only one control loop at a time is in operation. The controllers can be tuned in the same way as single-loop controllers. There may be some difficulties with conditions when the controller switches. With controllers having integral action, it is also necessary to track the integral states of those controllers that are not in operation. Selector control is very common in order to guarantee that variables remain within constraints. The technique is commonly used in the power industry for control in boilers, power systems, and nuclear reactors. The advantage is that it is built up of simple nonlinear components and PI and PID controllers. An alternative to selector control is to make a combination of ordinary controllers and logic. The following example illustrates the use of selector control.

So far we have only discussed maximum and minimum selectors, there are also other types of selectors such as the median selector whose output is the current median of the input signals. A special case is the two-out-of-three selector, commonly used for highly sensitive systems. To achieve high reliability it is possible to use redundant sensors and controllers. By inserting median selectors it is possible to have a system that will continue to function even if several components fail.

When using selector control it is important to have windup protection for controllers that are not selected, a simple way to do this is to feed use the output of the selected controller as the tracking signal for the other controllers.

### Repetitive Control

Attenuation of disturbances is a major reason for using feedback. Section ?? it was shown that attenuation of disturbances is captured by the transfer function from load disturbance to process output is

$$G_{yd} = \frac{P}{1+PC} \approx \frac{1}{C}, \quad \text{for } |C(i\omega)| \text{ large}, \quad (14.8)$$

where  $P$  is the process transfer function and  $C$  the controller transfer function. Having a large gain (while avoiding instability) is thus a good way to reduce the effect of disturbances. A typical case is the use of integral action to reduce the effect of low frequency disturbances.

In Section ?? it was shown that integral action could be implemented by positive feedback around a first order system as shown in Figure 14.6. The transfer function and the input output relation for the system in the figure is

$$C = \frac{1}{1-G_f}, \quad u = e + G_f u$$

Intuitively the system works as follows. The filter  $G_f$  filters out the signal component that we would like to eliminate, and the filtered output  $u$  of  $G_f$  is fed back to the input with positive feedback. The net effect is to create a high gain for the

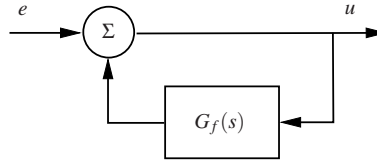

**Figure 14.6:** Block diagram of a controller with positive of a filtered output signal..

frequencies in the pass band of the filter  $G_f$ . There are many possible choices of the filter

$$\begin{aligned}
 C_{constant}(s) &= \frac{1}{1+sT}, & G_{ye} &= 1 + \frac{1}{sT} \\
 C_{sinusoidal}(s) &= \frac{2\zeta\omega_0 s}{s^2 + 2\zeta\omega_0 s + \omega_0^2}, & G_{ye} &= \frac{2\zeta\omega_0 s}{s^2 + \omega_0^2} \\
 C_{periodic}(s) &= e^{-s\tau}, & G_{ye} &= \frac{k}{1 - e^{-s\tau}}
 \end{aligned} \tag{14.9}$$

The controller transfer functions have infinite gains for  $s = 0$ ,  $s = i\omega_0$  and  $s = 2n\pi i/L$ ,  $n = 0, 1, \dots$ , respectively. The controllers will therefore eliminate, constant disturbances, sinusoidal disturbances with frequency  $\omega_0$  and periodic disturbances with period  $\tau$ . The input/output relation for  $C_{periodic}$  is

$$u(t) = ke(t) + u(t - \tau).$$

This control strategy which is called repetitive control has the property that action at time  $t$  is thus a sum of the control error  $e(t)$  and the delayed control signal  $u(t - \tau)$ . The controller will continue to make adjustments if there is a periodic variation in the error  $e$ .

#### Example 14.4 An Extreme Case

Consider a the case of a process whose dynamics is a pure delay, the transfer functions of the process and the controller are

$$P(s) = e^{-s\tau}, \quad C(s) = \frac{1}{1 - e^{-s\tau}}.$$

The loop transfer function

$$L(s) = \frac{e^{-s\tau}}{1 - e^{-s\tau}}$$

is periodic with period  $2\pi/\tau$ , and its gain is infinite for  $\omega = 2n\pi/\tau$ . The Nyquist plot of  $L$  is a vertical line through the point  $G_l = -0.5$  and a half circle to the right. This curve is transversed once for  $0 \leq \omega \leq 2\pi/\tau$  and infinitely many times when  $\omega$  increases towards infinity. The system has the gain margin 2 and the phase margin is  $60^\circ$ . The sensitivity functions are

$$S(s) = 1 - e^{-s\tau}, \quad T(s) = e^{-s\tau},$$

and we find that  $M_s = 2$  and  $M_t = 1$ .

A superficial look at robustness measures like gain margin  $g_m = 2$ , phase margin  $\varphi_m = 60^\circ$ , and maximum sensitivities  $M_s = 2$  and  $M_t = 1$  indicate that the system is robust to process perturbations. The fact that  $T(i\omega) = 1$  for all frequencies is, however, an indication that the system has unusual properties. Further insight is obtained by analysing the effect of parameter variations.

The system has only one parameter, the time delay  $\tau$ , and to explore robustness we will investigate the effects of variations in the time delay. Assume that the time delay changes from  $\tau$  to  $\tau + \delta\tau$ , then

$$e^{-s(\tau+\delta\tau)} = e^{-s\tau}e^{-s\delta\tau} = e^{-s\tau} + e^{-s\tau}(e^{-s\delta\tau} - 1).$$

A variation in the time delay can thus be represented by the additive perturbation

$$\Delta P(s) = e^{-s\tau}(e^{-s\delta\tau} - 1).$$

Hence  $|\Delta P(i\omega)| = |e^{-i\omega\delta\tau} - 1|$ .

Since  $|P(i\omega)| = 1$ , the robustness inequality (??) becomes

$$\frac{|\Delta P(i\omega)|}{|P(i\omega)|} = |e^{-i\omega\delta\tau} - 1| < \frac{1}{|T(i\omega)|} = 1.$$

This inequality is not satisfied for any  $\delta\tau > 0$  because the left-hand side is 2 and the right hand side is 1, and we cannot guarantee stability for an arbitrary small perturbation in the time delay.  $\nabla$

The example shows that the effective attenuation of periodic disturbances comes at the cost of the system being extremely sensitive to parameter variations. A compromise between disturbance attenuation can be made by replacing  $G_f(s)$  in Figure ?? by  $\alpha G_f(s)$  with  $\alpha < 1$ . The controllers obtained for constant, sinusoidal, and periodic signals then become

$$\begin{aligned} C_{constant}(s) &= \frac{1 + sT}{1 - \alpha + sT} \\ C_{sinusoidal}(s) &= \frac{s^2 + 2\zeta\omega_0s + \omega_0^2}{s^2 + 2(1 - \alpha)\zeta\omega_0s + \omega_0^2} \\ C_{periodic}(s) &= \frac{1}{1 - \alpha e^{-sT}}. \end{aligned}$$

The largest gains of the transfer functions are  $1/(1 - \alpha)$  in all cases. Choosing  $\alpha < 1$  diminishes disturbance attenuation but improves the robustness.

### Gain scheduling, Adaptation and Extremum Seeking

Feedback controllers can be designed to be robust to process variations, there is however a limit to what can be achieved by feedback. Other controller architectures are therefore use when there are large process variations. Gain scheduling is a technique that can be used when there are measured variables (scheduling variables) that correlate well with the process variations. A controller such as the

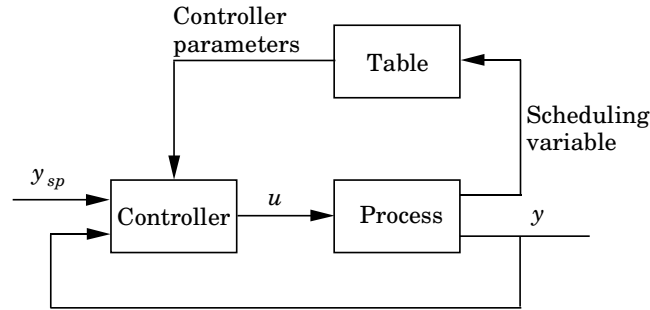

**Figure 14.7:** Block diagram of a system with gain scheduling.

one shown in the block diagram Figure 14.7 can be used. The controller design can then be performed for many values of the scheduling variables that are stored in a table. During operation table look up and interpolation are then used to find controller parameters that are appropriate for the different operating conditions. Systems with gain scheduling are routinely used for flight control where the scheduling variables are Mach number and height. In process control flow rates and production rates are typically used as scheduling variables.

Adaptive control where process parameters are estimated on line can also be used when it is not possible to find scheduling variables, a block diagram is shown in Figure 14.8

Among other useful control structures we can mention *extremum seeking* or *self-optimization*. Instead of keeping the process output close to a specified reference value these controllers attempt to change the reference so that an objective function is minimized. To accomplish this it is necessary to change the reference value of the controller and observe the effect of the output. A simple scheme idea is illustrated in Figure ???. The reference value of a controller is changed and the behavior of the performance criterion is observed. The performance changes very little close to the optimum. The changes of performance are in phase with the changes of the reference if the reference is too large and out of phase if the reference is too low. The reference is changed to move towards the smallest value of the objective function. Correlation methods can be used to filter out noise, since the argument is based on a steady-state reasoning the frequency of the perturbation signal must be chosen so low that process dynamics can be neglected. There are many other more sophisticated schemes based on optimization and estimation.

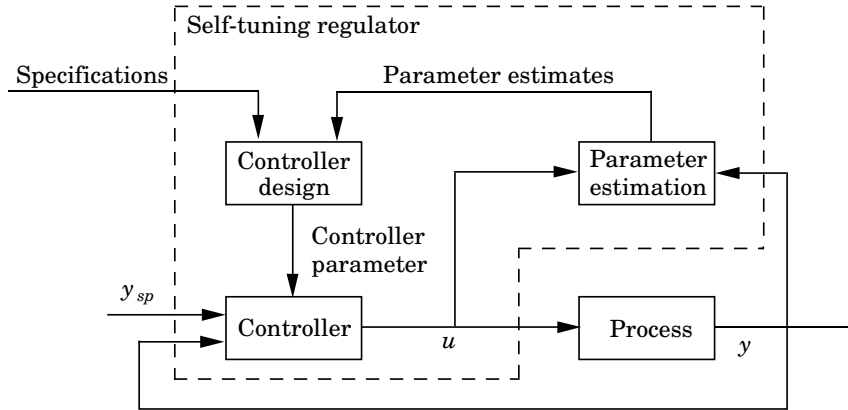

Figure 14.8: Block diagram of an adaptive controller.

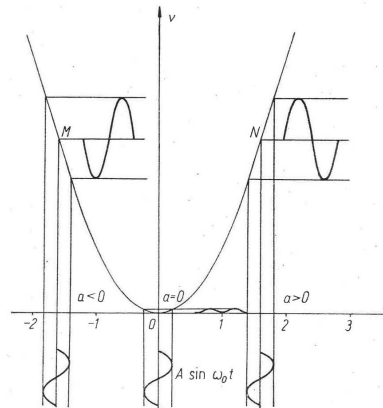
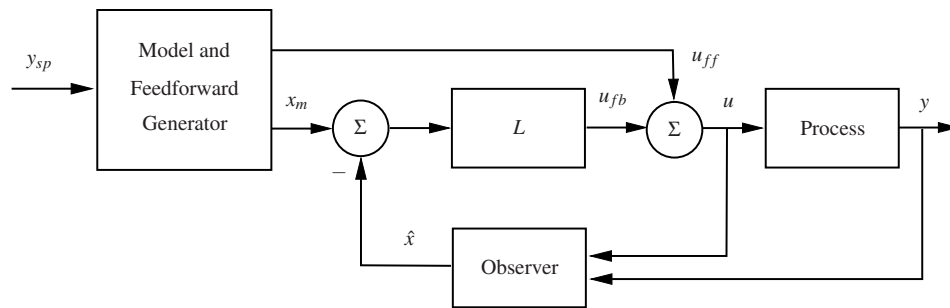

Figure 14.9: A simple principle for a self-optimizing controller. The figure shows the steady state response of the the performance variable  $v$  as a funtion of the reference  $y_r$ , and the effect of sinusoidal variations of the reference.



**Figure 14.10:** Block diagram of a controller based on model following, state feedback, and an observer.

## 14.2 Top-Down Architectures

- Introduction: controllers, logic
- Logic and FMS
- State Feedback and Observers
- State Based Control, FSM
- Model Predictive Control

### Top-Down Solutions

Top-down paradigms often start with a problem formulation in terms of an optimization problem. Paradigms that support a top-down approach are optimization, state feedback, observers, predictive control, and linearization. In the top-down approach it is natural to deal with many inputs and many outputs simultaneously. Since this is not the main topic of this book we will only give a brief discussion. The top-down approach often leads to the controller structure shown in Figure 14.10. In this system all measured process variables  $y$  together with the control variables  $u$  are sent to an observer, which uses the sensor information and a mathematical model to generate a vector  $\hat{x}$  of good estimates of internal process variables and important disturbances. The estimated state  $\hat{x}$  is then compared with the ideal state  $x_m$  produced by the feedforward generator, and the difference is fed back to the process. The feedforward generator also gives a feedforward signal  $u_{ff}$ , which is sent directly to the process inputs. The controller shown in Figure 14.10 is useful for process segments where there are several inputs and outputs that interact, but the system becomes very complicated when there is a large number of inputs and outputs. In such a case it may be better to decompose the system into several subsystems.

An advantage with the top-down approach is that the total behavior of the system is taken into account. A systematic approach based on mathematical modeling

and simulation makes it easy to understand the fundamental limitations. Commissioning of the system is, however, difficult because many feedback loops have to be closed simultaneously. When using the top-down approach it is therefore good practice to first tune loops based on simulation, possibly also hardware in the loop simulation.





---

---

## Bibliography

- [Abk69] M. A. Abkowitz. *Stability and Motion Control of Ocean Vehicles*. MIT Press, Cambridge, MA, 1969.
- [Ack72] J. Ackermann. Der Entwurf linearer Regelungssysteme im Zustandsraum. *Regelungstechnik und Prozessdatenverarbeitung*, 7:297–300, 1972.
- [Ack85] J. Ackermann. *Sampled-Data Control Systems*. Springer, Berlin, 1985.
- [Agn76] C. E. Agnew. Dynamic modeling and control of congestion-prone systems. *Operations Research*, 24(3):400–419, 1976.
- [ÅH05] K. J. Åström and T. Hägglund. *Advanced PID Control*. ISA—The Instrumentation, Systems, and Automation Society, Research Triangle Park, NC, 2005.
- [Ahl66] L. V. Ahlfors. *Complex Analysis*. McGraw-Hill, New York, 1966.
- [ÅKL05] K. J. Åström, R. E. Klein, and A. Lennartsson. Bicycle dynamics and control. *IEEE Control Systems Magazine*, 25(4):26–47, 2005.
- [Alu15] R. Alur. *Principles of Cyber-Physical Systems*. MIT Press, 2015.
- [AM90] B. D. O. Anderson and J. B. Moore. *Optimal Control Linear Quadratic Methods*. Prentice Hall, Englewood Cliffs, NJ, 1990. Republished by Dover Publications, 2007.
- [Apo67] T. M. Apostol. *Calculus*, Vol. II: *Multi-Variable Calculus and Linear Algebra with Applications*. Wiley, New York, 1967.
- [Apo69] T. M. Apostol. *Calculus*, Vol. I: *One-Variable Calculus with an Introduction to Linear Algebra*. Wiley, New York, 1969.
- [Ari94] R. Aris. *Mathematical Modeling Techniques*. Dover, New York, 1994. Originally published by Pitman, 1978.
- [Arn78] V. I. Arnold. *Mathematical Methods in Classical Mechanics*. Springer, New York, 1978.
- [Arn87] V. I. Arnold. *Ordinary Differential Equations*. MIT Press, Cambridge, MA, 1987. 10th printing 1998.
- [AS82] R. H. Abraham and C. D. Shaw. *Dynamics—The Geometry of Behavior*, Part 1: *Periodic Behavior*. Aerial Press, Santa Cruz, CA, 1982.
- [ASMN03] M. Atkinson, M. Savageau, J. Myers, and A. Ninfa. Development of genetic circuitry exhibiting toggle switch or oscillatory behavior in *Escherichia coli*. *Cell*, 113(5):597–607, 2003.
- [Åst00] K. J. Åström. Limitations on control system performance. *European Journal on Control*, 6(1):2–20, 2000.
- [Åst06] K. J. Åström. *Introduction to Stochastic Control Theory*. Dover, New York, 2006. Originally published by Academic Press, New York, 1970.
- [Ath75] D. P. Atherton. *Nonlinear Control Engineering*. Van Nostrand, New York, 1975.
- [AVK87] A. A. Andronov, A. A. Vitt, and S. E. Khaikin. *Theory of Oscillators*. Dover, New York, 1987.

- [ÅW97] K. J. Åström and B. Wittenmark. *Computer-Control Systems: Theory and Design*. Prentice Hall, Englewood Cliffs, NJ, 3rd edition, 1997.
- [ÅW08] K. J. Åström and B. Wittenmark. *Adaptive Control*. Dover, New York, 2nd edition, 2008. Originally published by Addison Wesley, 1995.
- [BÅ70] R. Bellman and K. J. Åström. On structural identifiability. *Mathematical Biosciences*, 7:329–339, 1970.
- [Bas01] T. Basar, editor. *Control Theory: Twenty-five Seminal Papers (1932–1981)*. IEEE Press, New York, 2001.
- [BB91] T. Basar and P. Bernhard.  *$H^\infty$ -Optimal Control and Related Minimax Design Problems: A Dynamic Game Approach*. Birkhauser, Boston, 1991.
- [BC48] G. S. Brown and D. P. Campbell. *Principles of Servomechanisms*. Wiley, New York, 1948.
- [BD04] W. E. Boyce and R. C. DiPrima. *Elementary Differential Equations*. Wiley, New York, 2004.
- [Bec05] J. Bechhoefer. Feedback for physicists: A tutorial essay on control. *Reviews of Modern Physics*, 77:783–836, 2005.
- [Ben79] S. Bennett. *A History of Control Engineering: 1800–1930*. Peter Peregrinus, Stevenage, 1979.
- [Ben93] S. Bennett. *A History of Control Engineering: 1930–1955*. Peter Peregrinus, Stevenage, 1993.
- [Ber54] L. L. Beranek. *Acoustics*. McGraw-Hill, New York, 1954.
- [Ber89] R. N. Bergman. Toward physiological understanding of glucose tolerance: Minimal model approach. *Diabetes*, 38:1512–1527, 1989.
- [BG68] B. Brawn and F. Gustavson. Program behavior in a paging environment. *Proceedings of the AFIPS Fall Joint Computer Conference*, pages 1019–1032, 1968.
- [BG87] D. Bertsekas and R. Gallager. *Data Networks*. Prentice Hall, Englewood Cliffs, 1987.
- [BH75] A. E. Bryson, Jr. and Y.-C. Ho. *Applied Optimal Control: Optimization, Estimation, and Control*. Wiley, New York, 1975.
- [Bia95] B. Bialkowski. Process control sample problems. In N. J. Sell, editor, *Process Control Fundamentals for the Pulp & Paper Industry*. Tappi Press, Norcross, GA, 1995.
- [BK64] R. E. Bellman and R. Kalaba. *Selected Papers on Mathematical Trends in Control Theory*. Dover, New York, 1964.
- [Bla34] H. S. Black. Stabilized feedback amplifiers. *Bell System Technical Journal*, 13:1–2, 1934.
- [Bla77] H. S. Black. Inventing the negative feedback amplifier. *IEEE Spectrum*, pages 55–60, 1977.
- [Bla91] J. H. Blakelock. *Automatic Control of Aircraft and Missiles*. Addison-Wesley, Cambridge, MA, 2nd edition, 1991.
- [Bli90] G. Blickley. Modern control started with Ziegler-Nichols tuning. *Control Engineering*, 37:72–75, 1990.
- [Bod45] H. W. Bode. *Network Analysis and Feedback Amplifier Design*. Van Nostrand, New York, 1945.
- [Bod60] H. W. Bode. Feedback—The history of an idea. In *Symposium on Active Networks and Feedback Systems*. Polytechnic Institute of Brooklyn, New York, 1960. Reprinted in [BK64].

- [BP96] M. B. Barron and W. F. Powers. The role of electronic controls for future automotive mechatronic systems. *IEEE Transactions on Mechatronics*, 1(1):80–89, 1996.
- [Bro70] R. W. Brockett. *Finite Dimensional Linear Systems*. Wiley, New York, 1970.
- [Bro00] R. W. Brockett. New issues in the mathematics of control. In B. Engquist and W. Schmid, editors, *Mathematics Unlimited—2001 and Beyond*, pages 189–220. Springer-Verlag, Berlin, 2000.
- [BRS60] J. F. Blackburn, G. Reethof, and J. L. Shearer. *Fluid Power Control*. MIT Press, Cambridge, MA, 1960.
- [Can03] R. H. Cannon. *Dynamics of Physical Systems*. Dover, New York, 2003. Originally published by McGraw-Hill, 1967.
- [CD75] R. F. Coughlin and F. F. Driscoll. *Operational Amplifiers and Linear Integrated Circuits*. Prentice Hall, Englewood Cliffs, NJ, 6th edition, 1975.
- [CD91] F. M. Callier and C. A. Desoer. *Linear System Theory*. Springer-Verlag, London, 1991.
- [CEHM10] M. Campbell, M. Egerstedt, J. P. How, and R. M. Murray. Autonomous driving in urban environments: Approaches, lessons and challenges. *Philosophical Transactions of the Royal Society – A*, 368(1928), 2010.
- [CJ59] H. S. Carslaw and J. C. Jaeger. *Conduction of Heat in Solids*. Clarendon Press, Oxford, UK, 2nd edition, 1959.
- [CM51] H. Chestnut and R. W. Mayer. *Servomechanisms and Regulating System Design*, Vol. 1. Wiley, New York, 1951.
- [Cro75] Crocus. *Systemes d'Exploitation des Ordinateurs*. Dunod, Paris, 1975.
- [CT84] C. Cobelli and G. Toffolo. Model of glucose kinetics and their control by insulin, compartmental and non-compartmental approaches. *Mathematical Biosciences*, 72(2):291–316, 1984.
- [DB04] R. C. Dorf and R. H. Bishop. *Modern Control Systems*. Prentice Hall, Upper Saddle River, NJ, 10th edition, 2004.
- [DFT92] J. C. Doyle, B. A. Francis, and A. R. Tannenbaum. *Feedback Control Theory*. Macmillan, New York, 1992.
- [DGH<sup>+</sup>02] Y. Diao, N. Gandhi, J. L. Hellerstein, S. Parekh, and D. M. Tilbury. Using MIMO feedback control to enforce policies for interrelated metrics with application to the Apache web server. In *Proceedings of the IEEE/IFIP Network Operations and Management Symposium*, pages 219–234, 2002.
- [DGKF89] J. C. Doyle, K. Glover, P. P. Khargonekar, and B. A. Francis. State-space solutions to standard  $H_2$  and  $H_\infty$  control problems. *IEEE Transactions on Automatic Control*, 34(8):831–847, 1989.
- [DH85] J. P. Den Hartog. *Mechanical Vibrations*. Dover, New York, 1985. Reprint of 4th ed. from 1956; 1st ed. published in 1934.
- [dJ02] H. de Jong. Modeling and simulation of genetic regulatory systems: A literature review. *Journal of Computational Biology*, 9:67–103, 2002.
- [DM02] L. Desborough and R. Miller. Increasing customer value of industrial control performance monitoring—Honeywell’s experience. In *Sixth International Conference on Chemical Process Control*. AIChE Symposium Series Number 326 (Vol. 98), 2002.
- [DM14] D. Del Vecchio and R. M. Murray. *Biomolecular Feedback Systems*. Princeton University Press, 2014.
- [Dos68] F. H. Dost. *Grundlagen der Pharmakokinetik*. Thieme Verlag, Stuttgart, 1968.

- [Doy78] J. C. Doyle. Guaranteed margins for LQG regulators. *IEEE Transactions on Automatic Control*, 23(4):756–757, 1978.
- [Dub57] L. E. Dubins. On curves of minimal length with a constraint on average curvature, and with prescribed initial and terminal positions and tangents. *American Journal of Mathematics*, 79:497–516, 1957.
- [Dys04] F. Dyson. A meeting with Enrico Fermi. *Nature*, 247(6972):297, 2004.
- [EG05] S. P. Ellner and J. Guckenheimer. *Dynamic Models in Biology*. Princeton University Press, Princeton, NJ, 2005.
- [EKR03] E. N. Elnozahy, M. Kistler, and R. Rajamony. Energy-efficient server clusters. In *Power-Aware Computer Systems*, pages 179–197. Springer, 2003.
- [EL00] M. B. Elowitz and S. Leibler. A synthetic oscillatory network of transcriptional regulators. *Nature*, 403(6767):335–338, 2000.
- [Eli94] J. R. Ellis. *Vehicle Handling Dynamics*. Mechanical Engineering Publications, London, 1994.
- [ESGK02] H. El-Samad, J. P. Goff, and M. Khammash. Calcium homeostasis and parturient hypocalcemia: An integral feedback perspective. *Journal of Theoretical Biology*, 214:17–29, 2002.
- [FCF<sup>+</sup>06] P. G. Fabietti, V. Canonico, M. O. Federici, M. Benedetti, and E. Sarti. Control oriented model of insulin and glucose dynamics in type 1 diabetes. *Medical and Biological Engineering and Computing*, 44:66–78, 2006.
- [FLMR92] M. Fliess, J. Levine, P. Martin, and P. Rouchon. On differentially flat nonlinear systems. *Comptes Rendus des Séances de l'Académie des Sciences, Serie I*, 315:619–624, 1992.
- [FLMR95] M. Fliess, J. Levine, P. Martin, and P. Rouchon. Flatness and defect of non-linear systems: Introductory theory and examples. *International Journal of Control*, 61(6):1327–1361, 1995.
- [For61] J. W. Forrester. *Industrial Dynamics*. MIT Press, Cambridge, MA, 1961.
- [Fou07] J. B. J. Fourier. On the propagation of heat in solid bodies. Memoir, read before the Class of the Instut de France, 1807.
- [FPEN05] G. F. Franklin, J. D. Powell, and A. Emami-Naeini. *Feedback Control of Dynamic Systems*. Prentice Hall, Upper Saddle River, NJ, 5th edition, 2005.
- [Fra87] B. A. Francis. *A Course in  $\mathcal{H}_\infty$  Control*. Springer-Verlag, Berlin, 1987.
- [Fra07] A. Fradkov. *Cybernetical Physics: From Control of Chaos to Quantum Control*. Springer, Berlin, 2007.
- [Fri04] B. Friedland. *Control System Design: An Introduction to State Space Methods*. Dover, New York, 2004.
- [Gan60] F. R. Gantmacher. *The Theory of Matrices*. Chelsea Publishing Company, 1960.
- [GB42] M. A. Gardner and J. L. Barnes. *Transients in Linear Systems*. Wiley, New York, 1942.
- [GF71] L. Gunkel and G. F. Franklin. A general solution for linear sampled data systems. *IEEE Transactions on Automatic Control*, AC-16:767–775, 1971.
- [GGs01] G. C. Goodwin, S. F. Graebe, and M. E. Salgado. *Control System Design*. Prentice Hall, Upper Saddle River, NJ, 2001.
- [GH83] J. Guckenheimer and P. Holmes. *Nonlinear Oscillations, Dynamical Systems, and Bifurcations of Vector Fields*. Springer-Verlag, Berlin, 1983.
- [Gil63] E. Gilbert. Controllability and observability in multivariable control systems. *SIAM Journal of Control*, 1(1):128–151, 1963.

- [GL95] M. Green and D. J. N. Limebeer. *Linear Robust Control*. Prentice Hall, Englewood Cliffs, NJ, 1995.
- [GM61] D. Graham and D. McRuer. *Analysis of Nonlinear Control Systems*. Wiley, New York, 1961.
- [God83] K. Godfrey. *Compartment Models and Their Application*. Academic Press, New York, 1983.
- [Gol53] H. Goldstein. *Classical Mechanics*. Addison-Wesley, Cambridge, MA, 1953.
- [Gol70] S. W. Golomb. Mathematical models—Uses and limitations. *Simulation*, 4(14):197–198, 1970.
- [GP82] M. Giobaldi and D. Perrier. *Pharmacokinetics*. Marcel Dekker, New York, 2nd edition, 1982.
- [GPD59] J. C. Gille, M. J. Pelegrin, and P. Decaulne. *Feedback Control Systems; Analysis, Synthesis, and Design*. McGraw-Hill, New York, 1959.
- [Gui63] E. A. Guillemin. *Theory of Linear Physical Systems*. MIT Press, Cambridge, MA, 1963.
- [Hah67] W. Hahn. *Stability of Motion*. Springer, Berlin, 1967.
- [HB90] J. K. Hedrick and T. Batsuen. Invariant properties of automobile suspensions. In *Proceedings of the Institution of Mechanical Engineers*, volume 204, pages 21–27, London, 1990.
- [HD95] M. B. Hoagland and B. Dodson. *The Way Life Works*. Times Books, New York, 1995.
- [HDPT04] J. L. Hellerstein, Y. Diao, S. Parekh, and D. M. Tilbury. *Feedback Control of Computing Systems*. Wiley, New York, 2004.
- [Her04] D. V. Herlihy. *Bicycle—The History*. Yale University Press, New Haven, CT, 2004.
- [HH52] A. L. Hodgkin and A. F. Huxley. A quantitative description of membrane current and its application to conduction and excitation in nerve. *Journal of Physiology*, 117(500–544), 1952.
- [HMTG00] C. V. Hollot, V. Misra, D. Towsley, and W-B. Gong. A control theoretic analysis of RED. In *Proceedings of IEEE Infocom*, pages 1510–1519, 2000.
- [Hor63] I. M. Horowitz. *Synthesis of Feedback Systems*. Academic Press, New York, 1963.
- [Hor75] I. M. Horowitz. Superiority of transfer function over state-variable methods in linear, time-invariant feedback system design. *IEEE Transactions on Automatic Control*, AC-20(1):84–97, 1975.
- [Hor91] I. M. Horowitz. Survey of quantitative feedback theory. *International Journal of Control*, 53:255291, 1991.
- [Hug93] T. P. Hughes. *Elmer Sperry: Inventor and Engineer*. John Hopkins University Press, Baltimore, MD, 1993.
- [HW00] D. Hanahan and R. A. Weinberg. The hallmarks of cancer. *Cell*, 100:57–70, 2000.
- [Isi95] A. Isidori. *Nonlinear Control Systems*. Springer-Verlag, Berlin, 3rd edition, 1995.
- [Ito70] M. Ito. Neurophysiological aspects of the cerebellar motor system. *International Journal of Neurology*, 7:162178, 1970.
- [Jac72] J. A. Jacquez. *Compartment Analysis in Biology and Medicine*. Elsevier, Amsterdam, 1972.
- [Jac95] V. Jacobson. Congestion avoidance and control. *ACM SIGCOMM Computer Communication Review*, 25:157–173, 1995.

- [Jan14] P. K. Janert. *Feedback Control for Computer Scientists*. O'Reilly Media, 2014.
- [JNP47] H. James, N. Nichols, and R. Phillips. *Theory of Servomechanisms*. McGraw-Hill, New York, 1947.
- [JT61] P. D. Joseph and J. T. Tou. On linear control theory. *Transactions of the AIEE*, 80(18), 1961.
- [Jun02] W. G. Jung, editor. *Op Amp Applications*. Analog Devices, Norwood, MA, 2002.
- [Kal60] R. E. Kalman. Contributions to the theory of optimal control. *Boletín de la Sociedad Matemática Mexicana*, 5:102–119, 1960.
- [Kal61a] R. E. Kalman. New methods and results in linear prediction and filtering theory. Technical Report 61-1, Research Institute for Advanced Studies (RIAS), Baltimore, MD, February 1961.
- [Kal61b] R. E. Kalman. On the general theory of control systems. In *Proceedings of the First IFAC Congress on Automatic Control, Moscow, 1960*, volume 1, pages 481–492. Butterworths, London, 1961.
- [KB61] R. E. Kalman and R. S. Bucy. New results in linear filtering and prediction theory. *Transactions of the ASME (Journal of Basic Engineering)*, 83 D:95–108, 1961.
- [Kel85] F. P. Kelly. Stochastic models of computer communication. *Journal of the Royal Statistical Society*, B47(3):379–395, 1985.
- [Kel94] K. Kelly. *Out of Control*. Addison-Wesley, Reading, MA, 1994. Available at <http://www.kk.org/outofcontrol>.
- [KFA69] R. E. Kalman, P. L. Falb, and M. A. Arbib. *Topics in Mathematical System Theory*. McGraw-Hill, New York, 1969.
- [KG02] B. C. Kuo and F. Golnaraghi. *Automatic Control Systems*. Wiley, New York, 8th edition, 2002.
- [Kha01] H. K. Khalil. *Nonlinear Systems*. Macmillan, New York, 3rd edition, 2001.
- [KHN63] R. E. Kalman, Y. Ho, and K. S. Narendra. *Controllability of Linear Dynamical Systems*, volume 1 of *Contributions to Differential Equations*. Wiley, New York, 1963.
- [Kit95] C. Kittel. *Introduction to Solid State Physics*. Wiley, New York, 1995.
- [KKK95] M. Krstić, I. Kanellakopoulos, and P. Kokotović. *Nonlinear and Adaptive Control Design*. Wiley, 1995.
- [Kle75] L. Kleinrock. *Queueing Systems*, Vols. I and II. Wiley-Interscience, New York, 2nd edition, 1975.
- [KN00] U. Kiencke and L. Nielsen. *Automotive Control Systems: For Engine, Driveline, and Vehicle*. Springer, Berlin, 2000.
- [Kra63] N. N. Krasovski. *Stability of Motion*. Stanford University Press, Stanford, CA, 1963.
- [KS01] J. Keener and J. Sneyd. *Mathematical Physiology*. Springer, New York, 2001.
- [Kum01] P. R. Kumar. New technological vistas for systems and control: The example of wireless networks. *Control Systems Magazine*, 21(1):24–37, 2001.
- [Kun93] P. Kundur. *Power System Stability and Control*. McGraw-Hill, New York, 1993.
- [KV86] P. R. Kumar and P. Varaiya. *Stochastic Systems: Estimation, Identification, and Adaptive Control*. Prentice Hall, Englewood Cliffs, NJ, 1986.
- [LaS60] J. P. LaSalle. Some extensions of Lyapunov's second method. *IRE Transactions on Circuit Theory*, CT-7(4):520–527, 1960.

- [Lew03] A. D. Lewis. A mathematical approach to classical control. Technical report, Queens University, Kingston, Ontario, 2003.
- [Lju99] L. Ljung. *System Identification – Theory for the User*. Prentice Hall, Upper Saddle River, NJ, 2nd edition, 1999.
- [LPD02] S. H. Low, F. Paganini, and J. C. Doyle. Internet congestion control. *IEEE Control Systems Magazine*, pages 28–43, February 2002.
- [LPW<sup>+</sup>02] S. H. Low, F. Paganini, J. Wang, S. Adlakha, and J. C. Doyle. Dynamics of TCP/RED and a scalable control. In *Proceedings of IEEE Infocom*, pages 239–248, 2002.
- [LS15] E. A. Lee and S. A. Seshia. *Introduction to Embedded Systems, A Cyber-Physical Systems Approach*. <http://LeeSeshia.org>, 2015. ISBN 978-1-312-42740-2.
- [Lun05] K. H. Lundberg. History of analog computing. *IEEE Control Systems Magazine*, pages 22–28, March 2005.
- [MÅB<sup>+</sup>03] R. M. Murray, K. J. Åström, S. P. Boyd, R. W. Brockett, and G. Stein. Future directions in control in an information-rich world. *Control Systems Magazine*, April 2003.
- [Mac37] D. A. MacLulich. *Fluctuations in the Numbers of the Varying Hare (Lepus americanus)*. University of Toronto Press, 1937.
- [Mac45] L.A. MacColl. *Fundamental Theory of Servomechanisms*. Van Nostrand, Princeton, NJ, 1945. Dover reprint 1968.
- [Mac89] J. M. Maciejowski. *Multivariable Feedback Design*. Addison Wesley, Reading, MA, 1989.
- [Mal59] J. G. Malkin. *Theorie der Stabilität einer Bewegung*. Oldenbourg, München, 1959.
- [Man02] R. Mancini. *Op Amps for Everyone*. Texas Instruments, Houston, TX, 2002.
- [May70] O. Mayr. *The Origins of Feedback Control*. MIT Press, Cambridge, MA, 1970.
- [McF53] M. W. McFarland, editor. *The Papers of Wilbur and Orville Wright*. McGraw-Hill, New York, 1953.
- [MG90] D. C. McFarlane and K. Glover. *Robust Controller Design Using Normalized Coprime Factor Plant Descriptions*. Springer, New York, 1990.
- [MH98] J. E. Marsden and M. J. Hoffmann. *Basic Complex Analysis*. W. H. Freeman, New York, 1998.
- [Mil66] H. T. Milhorn. *The Application of Control Theory to Physiological Systems*. Saunders, Philadelphia, 1966.
- [Min02] D. A. Mindel. *Between Human and Machine: Feedback, Control, and Computing Before Cybernetics*. Johns Hopkins University Press, Baltimore, MD, 2002.
- [Min08] D. A. Mindel. *Digital Apollo: Human and Machine in Spaceflight*. The MIT Press, Cambridge, MA, 2008.
- [MLK06] A. Makroglou, J. Li, and Y. Kuang. Mathematical models and software tools for the glucose-insulin regulatory system and diabetes: An overview. *Applied Numerical Mathematics*, 56:559–573, 2006.
- [MLS94] R. M. Murray, Z. Li, and S. S. Sastry. *A Mathematical Introduction to Robotic Manipulation*. CRC Press, 1994.
- [MR94] J. E. Marsden and T. S. Ratiu. *Introduction to Mechanics and Symmetry*. Springer-Verlag, New York, 1994.
- [Mur03] R. M. Murray, editor. *Control in an Information Rich World: Report of the Panel on Future Directions in Control, Dynamics and Systems*. SIAM, Philadelphia, 2003.

- [Mur04] J. D. Murray. *Mathematical Biology*, Vols. I and II. Springer-Verlag, New York, 3rd edition, 2004.
- [Nah88] P. J. Nahin. *Oliver Heaviside: Sage in Solitude: The Life, Work and Times of an Electrical Genius of the Victorian Age*. IEEE Press, New York, 1988.
- [NS99] H. Nijmeijer and J. M. Schumacher. Four decades of mathematical system theory. In J. W. Polderman and H. L. Trentelman, editors, *The Mathematics of Systems and Control: From Intelligent Control to Behavioral Systems*, pages 73–83. University of Groningen, 1999.
- [Nyq32] H. Nyquist. Regeneration theory. *Bell System Technical Journal*, 11:126–147, 1932.
- [Nyq56] H. Nyquist. The regeneration theory. In R. Oldenburger, editor, *Frequency Response*, page 3. MacMillan, New York, 1956.
- [Oga01] K. Ogata. *Modern Control Engineering*. Prentice Hall, Upper Saddle River, NJ, 4th edition, 2001.
- [Old56] R. Oldenburger, editor. *Frequency Response*. MacMillan, New York, 1956.
- [OSFM07] R. Olfati-Saber, J. A. Fax, and R. M. Murray. Consensus and cooperation in networked multi-agent systems. *Proceedings of the IEEE*, 95(1):215–233, 2007.
- [PB86] G. Pacini and R. N. Bergman. A computer program to calculate insulin sensitivity and pancreatic responsivity from the frequently sampled intravenous glucose tolerance test. *Computer Methods and Programs in Biomedicine*, 23:113–122, 1986.
- [Phi48] G. A. Philbrick. Designing industrial controllers by analog. *Electronics*, 21(6):108–111, 1948.
- [PN00] W. F. Powers and P. R. Nicastrì. Automotive vehicle control challenges in the 21st century. *Control Engineering Practice*, 8:605–618, 2000.
- [PPP02] S. Prajna, A. Papachristodoulou, and P. A. Parrilo. SOSTOOLS: Sum of squares optimization toolbox for MATLAB, 2002. Available from <http://www.cds.caltech.edu/sostools>.
- [Pto14] Claudius Ptolemaeus, editor. *System Design, Modeling, and Simulation using Ptolemy II*. Ptolemy.org, 2014.
- [Pyt] Python control systems library. Available from <http://python-control.org>.
- [Rig63] D. S. Riggs. *The Mathematical Approach to Physiological Problems*. MIT Press, Cambridge, MA, 1963.
- [RM71] H. H. Rosenbrock and P. D. Moran. Good, bad or optimal? *IEEE Transactions on Automatic Control*, AC-16(6):552–554, 1971.
- [RST12] G. Rafal, R. G. Sanfelice, and A. Teel. *Hybrid Dynamical Systems: Modeling, Stability, and Robustness*. Princeton University Press, 2012.
- [Rug95] W. J. Rugh. *Linear System Theory*. Prentice Hall, Englewood Cliffs, NJ, 2nd edition, 1995.
- [SÅD<sup>+</sup>07] G. Schitter, K. J. Åström, B. DeMartini, P. J. Thurner, K. L. Turner, and P. K. Hansma. Design and modeling of a high-speed AFM-scanner. *IEEE Transactions on Control System Technology*, 15(5):906–915, 2007.
- [Sar91] D. Sarid. *Atomic Force Microscopy*. Oxford University Press, Oxford, UK, 1991.
- [Sas99] S. Sastry. *Nonlinear Systems*. Springer, New York, 1999.
- [Sch87] M. Schwartz. *Telecommunication Networks*. Addison Wesley, Reading, MA, 1987.
- [Sch01] G. Schitter. High performance feedback for fast scanning atomic force microscopes. *Review of Scientific Instruments*, 72(8):3320–3327, 2001.



- [SEM04] D. E. Seborg, T. F. Edgar, and D. A. Mellichamp. *Process Dynamics and Control*. Wiley, Hoboken, NJ, 2nd edition, 2004.
- [Sen01] S. D. Senturia. *Microsystem Design*. Kluwer, Boston, MA, 2001.
- [Shi96] F. G. Shinskey. *Process-Control Systems. Application, Design, and Tuning*. McGraw-Hill, New York, 4th edition, 1996.
- [Smi52] J. M. Smith. The importance of the nervous system in the evolution of animal flight. *Evolution*, 6(1):127–129, 1952.
- [Son98] E. P. Sontag. *Mathematical Control Theory: Deterministic Finite Dimensional Systems*. Springer, New York, 2nd edition, 1998.
- [SP05] S. Skogestad and I Postlethwaite. *Multivariable Feedback Control*. Wiley, Hoboken, NJ, 2nd edition, 2005.
- [SS02] E. B. Saff and A. D. Snider. *Fundamentals of Complex Analysis with Applications to Engineering, Science and Mathematics*. Prentice Hall, Englewood Cliffs, NJ, 2002.
- [Sta68] L. Stark. *Neurological Control Systems—Studies in Bioengineering*. Plenum Press, New York, 1968.
- [Ste02] J. Stewart. *Calculus: Early Transcendentals*. Brooks Cole, Pacific Grove, CA, 2002.
- [Ste03] G. Stein. Respect the unstable. *Control Systems Magazine*, 23(4):12–25, 2003.
- [Str88] G. Strang. *Linear Algebra and Its Applications*. Harcourt Brace Jovanovich, San Diego, 3rd edition, 1988.
- [Str94] S. H. Strogatz. *Nonlinear Dynamics and Chaos, with Applications to Physics, Biology, Chemistry, and Engineering*. Addison-Wesley, Reading, MA, 1994.
- [SV89] M. W. Spong and M. Vidyasagar. *Dynamics and Control of Robot Manipulators*. John Wiley, 1989.
- [Tan96] A. S. Tannenbaum. *Computer Networks*. Prentice Hall, Upper Saddle River, NJ, 3rd edition, 1996.
- [Teo37] T. Teorell. Kinetics of distribution of substances administered to the body, I and II. *Archives Internationales de Pharmacodynamie et de Therapie*, 57:205–240, 1937.
- [Tha89] G. T. Thaler. *Automatic Control Systems*. West Publishing, St. Paul, MN, 1989.
- [Til01] M. Tiller. *Introduction to Physical Modeling with Modelica*. Springer, Berlin, 2001.
- [Tru55] J. G. Truxal. *Automatic Feedback Control System Synthesis*. McGraw-Hill, New York, 1955.
- [TS90] D. Tipper and M. K. Sundareshan. Numerical methods for modeling computer networks under nonstationary conditions. *IEEE Journal of Selected Areas in Communications*, 8(9):1682–1695, 1990.
- [Tsi54] H. S. Tsien. *Engineering Cybernetics*. McGraw-Hill, New York, 1954.
- [Tus52] A. Tustin. Feedback. *Scientific American*, 48–54, 1952.
- [Vin01] G. Vinnicombe. *Uncertainty and Feedback:  $\mathcal{H}_\infty$  Loop-Shaping and the  $v$ -Gap Metric*. Imperial College Press, London, 2001.
- [Whi99] F. J. W. Whipple. The stability of the motion of a bicycle. *Quarterly Journal of Pure and Applied Mathematics*, 30:312–348, 1899.
- [Wid41] D. V. Widder. *Laplace Transforms*. Princeton University Press, Princeton, NJ, 1941.
- [Wie48] N. Wiener. *Cybernetics: Or Control and Communication in the Animal and the Machine*. Wiley, 1948.

- [Wig90] S. Wiggins. *Introduction to Applied Nonlinear Dynamical Systems and Chaos*. Springer-Verlag, Berlin, 1990.
- [Wil99] H. R. Wilson. *Spikes, Decisions, and Actions: The Dynamical Foundations of Neuroscience*. Oxford University Press, Oxford, UK, 1999.
- [Wil04] D. G. Wilson. *Bicycling Science*. MIT Press, Cambridge, MA, 3rd edition, 2004. With contributions by Jim Papadopoulos.
- [Wis07] K. A. Wise. Guidance and control for military systems: Future challenges. In *AIAA Conference on Guidance, Navigation, and Control, 2007*. AIAA Paper 2007-6867.
- [WT24] E. P. M. Widmark and J. Tandberg. Über die Bedingungen für die Akkumulation indifferenten Narkotika. *Biochemische Zeitung*, 148:358–389, 1924.
- [YH91] S. Yamamoto and I. Hashimoto. Present status and future needs: The view from Japanese industry. In Y. Arkun and W. H. Ray, editors, *Chemical Process Control—CPC IV*, 1991.
- [YHSD00] T.-M. Yi, Y. Huang, M. I. Simon, and J. Doyle. Robust perfect adaptation in bacterial chemotaxis through integral feedback control. *PNAS*, 97:4649–4653, 2000.
- [Zam81] G. Zames. Feedback and optimal sensitivity: Model reference transformations, multiplicative seminorms, and approximative inverse. *IEEE Transactions on Automatic Control*, AC-26(2):301–320, 1981.
- [ZD63] L. A. Zadeh and C. A. Desoer. *Linear System Theory: the State Space Approach*. McGraw-Hill, New York, 1963.
- [ZDG96] J. C. Zhou, J. C. Doyle, and K. Glover. *Robust and Optimal Control*. Prentice Hall, Englewood Cliffs, NJ, 1996.
- [ZN42] J. G. Ziegler and N. B. Nichols. Optimum settings for automatic controllers. *Transactions of the ASME*, 64:759–768, 1942.

---

---

# Index

- $\mathcal{E}$ , 9-5
- +, 1-5, 4-13, 4-18, 4-25, 4-29
- acausal modeling, 3-7
- access control, *see* admission control
- acknowledgment (ack) packet, 4-13–4-15
- activator, 1-11, 3-39, 5-36
- active filter, *see also* operational amplifier, 6-24
- actuators, 1-4, 3-5, 3-30, 4-1, 4-17, 7-12, 8-25, 9-37, 10-17, 11-21, 12-11, 12-23–12-25, 12-27
  - effect on zeros, 10-17, 12-24
  - in computing systems, 4-11
  - saturation, 3-9, 8-26, 11-14–11-16, 11-21, 12-11
- A/D converters, *see* analog-to-digital converters
- adaptation, 11-5, 14-1, 14-11–14-12
- adaptive control, 13-28, 13-29
- additive uncertainty, 13-3, 13-7, 13-10, 13-31
- adjacency matrix, 3-36
- admission control, 3-33, 3-43, 4-14, 4-15, 10-8
- aerospace systems, *see also* vectored thrust aircraft; X-29 aircraft, 1-6, 1-13, 12-29
- AFM, *see* atomic force microscope
- air-fuel ratio control, 1-20
- aircraft, *see* flight control
- alcohol, metabolism of, 4-30
- algebraic loops, 3-26, 8-11
- aliasing, 8-26
- all-pass transfer function, 12-21
- alternating current (AC), 6-25
- amplifier, *see* operational amplifier
- amplitude ratio, *see* gain
- analog computing, 3-10, 3-26, 4-7, 11-20
- analog implementation, controllers, 4-10, 9-35, 11-20–11-21
- analog-to-digital converters, 1-4, 4-18, 8-25, 11-21
- angle, 2-4
- anti-windup compensation, 1-18
- anticipation, in controllers, *see also* derivative action, 1-18, 11-5
- antiresonance, 6-26
- anti-windup compensation, 11-15–11-16, 11-21, 11-23, 11-25
- Apache web server, *see also* web server control, 4-12
- apparent volume of distribution, 4-22, 4-30
- Arbib, M. A., 7-1
- argument, of a complex number, 9-24
- arrival rate (queuing systems), 3-33
- asymptotes, in Bode plot, 9-26, 9-27
- asymptotic stability, 3-21, 5-8, 5-10, 5-12, 5-13, 5-18, 5-20, 5-23–5-25, 5-27, 6-10
  - discrete-time systems, 6-35
- atmospheric dynamics, *see* environmental science
- atomic force microscopes, 1-3, 3-30, 4-17–4-20
- contact mode, 4-17, 6-26, 7-34
- horizontal positioning, 10-15, 13-20
- system identification, 9-31
- tapping mode, 4-17, 10-24, 11-7, 11-12, 12-14
  - with preloading, 4-29
- attractor (equilibrium point), 5-10
- automatic reset, in PID control, 11-4
- automatic tuning, 11-14, 13-28
- automation, 3-5
- automotive control systems, *see also* cruise control; vehicle steering, 1-15, 3-30, 4-5
- autonomous differential equation, *see also* time-invariant systems, 3-3
- autopilot, 1-13, 1-14
- balance systems, *see also* cart-pendulum system; inverted pendulum, 3-12–3-13, 3-29, 7-4, 7-23, 9-14, 12-25
- band-pass filter, 6-24, 6-25, 9-29
- bandwidth, 6-25, 7-20, 12-8, 12-23
- behavioral modeling, 3-7
- Bell Labs, 1-12, 10-23
- Bennett, S., 1-26, 10-24, 11-23
- bicycle dynamics, 4-5–4-7, 4-27, 5-29, 8-27
  - Whipple model, 4-7
- bicycle model, 3-31
- bicycle model, for vehicle steering, 3-30–3-32

- bicycledynamics
    - Whipple model, 7-34
  - bifurcations, *see also* root
    - locus plots, 5-28–5-30, 5-36
  - biological circuits, 1-11, 3-24, 3-38–3-39, 5-36, 6-36, 9-29
    - genetic switch, 3-43, 5-21
    - repressilator, 3-39
  - biological systems, *see also*
    - biological circuits; drug administration; neural systems; population dynamics, 1-1–1-3, 1-7, 1-10, 1-16, 1-26, 3-38–3-40, 5-33, 11-1, 11-5
  - bistability, 1-16, 5-23
  - Black, H. S., 1-12, 1-13, 4-7, 4-9, 6-1, 10-1, 10-24, 13-1
  - block diagonal form, 5-12, 5-36, 6-19
  - block diagonal systems, 5-12, 5-36, 6-9, 6-15, 6-19, 8-12
  - block diagram
    - finding transfer functions by inspection, 2-8
    - simplified writing of equations, 2-8
  - block diagram algebra, 9-18, 9-21, 13-10
  - block diagrams, 1-1, 3-23–3-26, 9-8, 9-18–9-23
  - control system, 1-4, 9-1, 9-20, 12-1
    - Kalman decomposition, 8-23
  - observable canonical form, 8-5
  - observer, 8-2, 8-10
  - observer-based control system, 8-14
  - PID controllers, 11-1, 11-4, 11-21
  - reachable canonical form, 7-7
  - two degree-of-freedom controller, 8-20, 12-2, 13-12
  - Youla parameterization, 13-11
- Bode, H., 9-1, 10-23, 10-24, 12-34, 13-28
  - Bode plots, 9-24–9-30, 10-16
    - asymptotic approximation, 9-26, 9-27, 9-36
    - low-, band-, high-pass filters, 9-29
    - nonminimum phase systems, 10-17
    - of rational function, 9-24
    - sketching, 9-27
  - Bode's ideal loop transfer function, 13-10, 13-29
  - Bode's integral formula, 12-25–12-27, 12-29–12-30
  - Bode's relations, 10-16, 12-13
  - Brahe, T., 3-2
  - breakpoint, 9-26, 10-6
  - Bristol's RGA, 14-3
  - Brockett, R. W., xii, 1-1, 6-33
  - Bryson, A. E., 7-35
  - bump test, 11-10
  - bumpless transfer, 13-28
  - bumpptest, 11-11
  - Bush, V., 11-23
  - business systems, 1-16
- calibration, versus feedback, 1-7, 7-14, 7-30, 7-31
  - Cannon, R. H., 3-40, 6-1
  - capacitor, transfer function for, 9-7
  - car, *see* automotive control systems; cruise control; vehicle steering
  - carrying capacity, in population models, 4-26
  - cart-pendulum system, *see also* balance systems, 2-24, 3-12, 3-13, 7-6
  - cascade control, 14-1, 14-3–14-5
    - applications, 14-5
    - disturbance rejection, 14-4
    - windup, 14-5
  - causal reasoning, 1-1, 4-6
  - Cayley-Hamilton theorem, 7-4, 7-34, 8-3
  - center (equilibrium point), 5-10
  - centrifugal governor, 1-2, 1-3, 1-11
  - chain of integrators (normal form), 3-41, 7-7
  - characteristic equation, 2-2, 2-5
  - characteristic polynomial, 2-1, 5-11, 7-34, 9-14
    - for closed loop transfer function, 10-2
  - observable canonical form, 8-5
  - output feedback controller, 8-12, 8-13
  - reachable canonical form, 7-7, 7-9, 7-13, 7-33
- chemical systems, *see also* process control; compartment models, 1-6, 11-1
  - chordal distance, 13-5
  - circuits, *see* biological circuits; electrical circuits
  - class  $\mathcal{E}$ , 9-5
  - classical control, xi, 13-28
  - closed loop, 1-1, 1-2, 1-4, 6-32, 7-10, 7-17, 10-1, 10-2, 10-20, 12-1
    - versus open loop, 1-2, 10-3, 10-21, 12-1
  - closed loop behavior, 10-1
  - Command signal following, 2-12
  - command signals, *see also* reference signal; setpoint, 1-4, 1-16, 8-20, 11-1
  - compartment models, 4-21–4-25, 5-13, 6-21, 7-20, 8-3, 8-8, 8-28
    - exercises, 6-34
  - compensator, *see* control law
  - complementary sensitivity function, 12-3, 12-11, 12-27, 13-5, 13-8, 13-11, 13-14, 13-19, 13-23, 13-29
  - complexity, of control systems, 1-7, 1-15, 11-6
  - computed torque, 6-33
  - computer implementation, controllers, 8-24–8-26, 11-21–11-23

- computer science, relationship to control, 1-5
- computer systems, control of, *see also* queuing systems, 1-8–1-9, 1-26, 3-16, 3-35, 3-36, 4-11–4-17, 6-27
- conditional integration, 11-25
- conditional stability, 10-9
- congestion control, *see also* queuing systems, 1-8, 4-13–4-16, 5-10, 10-7, 10-25, 11-24
  - router dynamics, 4-29
- consensus, 3-36
- control
  - definition of, 1-3–1-5
  - early examples, 1-2, 1-5, 1-6, 1-12, 1-15, 1-26, 11-4
  - fundamental limitations, 10-17, 12-21–12-30, 12-34, 13-18, 13-20, 13-27–13-28
  - history of, 1-26, 11-23
  - modeling for, 1-5, 3-5–3-6, 3-40, 13-1
  - successes of, 1-6, 1-26
  - system, 1-3, 7-9, 8-14, 8-19, 8-25, 9-1, 12-2, 12-5, 13-12
  - using estimated state, 8-11–8-14, 13-24
- Control architecture
  - two degrees of freedom, 2-14
- control architecture
  - two degrees of freedom, 2-14
- control error, 1-17, 9-20, 11-2
- control law, 1-4, 1-17, 1-18, 6-32, 7-10, 7-13, 9-20
- control Lyapunov function, 5-31
- control matrix, 3-11, 3-14
- control signal, 3-6, 6-27, 11-1
- controllability, *see also* reachability, 7-32
- controlled differential equation, 3-3, 3-11
- convolution equation, 6-15–6-17, 6-19, 6-20, 7-4, 9-12
- discrete-time, 6-35
- coordinate transformations, 5-12, 6-17–6-19, 7-7, 8-27, 9-12–9-13
  - to Jordan form, 6-9
  - to observable canonical form, 8-6
  - to reachable canonical form, 7-8, 7-9
- Coriolis forces, 3-12, 6-33
- corner frequency, 9-26
- correlation matrix, 8-15, 8-16
- cost function, 7-25
- coupled spring-mass system, 6-12, 6-14, 6-18
- covariance matrix, 8-15
- critical gain, 11-11, 11-13, 11-14
- critical period, 11-11, 11-13
- critical point, 10-2, 10-5, 10-7, 10-13, 10-22, 10-23, 11-11, 13-6, 13-7, 13-27
- critically damped oscillator, 7-18
- crossover frequency, *see* gain crossover frequency; phase crossover frequency
- crossover frequency inequality, *see* gain crossover frequency inequality
- cruise control, 1-12, 1-22, 4-1–4-5
  - control design, 7-30, 11-8, 11-19
  - electric car, 14-5
  - feedback linearization, 6-32
  - integrator windup, 11-14, 11-15
  - linearization, 6-28
  - pole/zero cancellation, 9-17
  - robustness, 1-12, 13-1, 13-2, 13-8
- Curtiss seaplane, 1-13, 1-14
- cybernetics, *see also* robotics, 1-7
- cyberphysical system, 3-8
- D/A converters, *see* digital-to-analog converters
- damped frequency, 7-19
- damping, 3-2, 3-12, 3-19, 5-2, 9-37, 9-38
- damping ratio, 2-11, 7-18, 7-19, 7-22
- DC gain, *see also* zero frequency gain, 6-25
- dead zone, 1-17
- decoupling, 14-3
  - direct, 14-3
- decoupling:feedback, 14-3
- delay, *see* time delay
- delay compensation, 10-25, 13-30
- delay margin, 10-15
- delta function, *see* impulse function
- derivative action, 1-18, 1-19, 11-1, 11-4–11-6, 11-20, 12-17
  - filtering, 11-5, 11-18–11-19, 11-22, 11-23
  - setpoint weighting, 11-19, 11-23
  - time constant, 11-2
  - versus lead compensator, 12-17
- derivative gain, 11-2
- derivative time constant, 11-5
- describing functions, 10-21–10-23
- design of dynamics, 1-12–1-14, 5-15, 5-30–5-32, 6-1, 7-1, 7-11, 7-17
- diabetes, *see* insulin-glucose dynamics
- diagonal systems, 5-12, 6-8
  - Kalman decomposition for, 8-23
  - transforming to, 5-12, 5-36, 6-8
- difference equations, 3-10, 3-14–3-17, 3-20, 3-41, 6-27, 8-25, 11-22
- differential algebraic equations, *see also* algebraic loops, 3-7
- differential equations, 3-2, 3-10–3-14, 5-1–5-4
  - controlled, 3-3, 6-3
  - equilibrium points, 5-6–5-7
  - existence and uniqueness of solutions, 5-2–5-4
  - first-order, 3-6, 11-6

- isolated solution, 5-7
- periodic solutions, 5-7–5-8, 5-16
- qualitative analysis, 5-4–5-8
- second-order, 5-5, 7-18, 11-6
- solutions, 5-1, 5-2, 6-3, 6-6, 6-15, 9-34
- stability, *see* stability
- transfer functions for, 9-10
- differential flatness, 8-22
- digital control systems, *see* computer implementation, controllers
- digital-to-analog converters, 1-4, 4-18, 8-25, 11-21
- dimension-free variables, 3-28, 3-40
- direct connection, 3-26
- direct decoupling, 14-3
- direct term, 3-11, 3-14, 3-26, 6-17, 8-11
- discrete control, 3-35
- discrete-time systems, 3-14, 3-41, 5-35, 6-27, 6-35, 11-21
  - Kalman filter for, 8-14
  - linear quadratic regulator for, 7-27
- disk drives, 3-44
- disturbance attenuation, 1-4, 7-10, 12-10–12-11, 13-13
- design of controllers for, 12-6, 12-13, 12-27, 12-35, 13-24
- fundamental limits, 12-26
- in biological systems, 9-30, 11-5
- integral gain as a measure of, 11-4, 12-11, 13-13
- relationship to sensitivity function, 12-10, 12-25, 12-35, 13-13
- disturbance weighting, 13-27
- disturbances, 1-4, 3-3, 3-6, 9-17, 9-20, 12-1, 12-4, 12-5
  - generalized, 13-25
  - random, 8-15
- Dodson, B., 1-1
- dominant eigenvalues (poles), 7-22, 11-9
- dominant pairs, 7-34
- double integrator, 2-5, 6-7, 7-2, 9-10, 10-25
- Doyle, J. C., xii, 12-34, 13-28
- drug administration, *see also* compartment models, 4-21–4-25, 4-30, 6-21, 7-20
- duality, 8-7, 8-11
- Dubins car, 3-31
- dynamic compensator, 7-30
- dynamic inversion, 6-33
- dynamical systems, 1-1, 3-1, 5-1, 5-4, 5-32
  - linear, 5-11, 6-1
  - observer as a, 8-1
  - state of, 7-9
  - stochastic, 8-14
  - uncertainty in, 13-1–13-3
  - zz*, *see also* differential equations
- dynamics matrix, 3-11, 3-14, 5-11, 6-12
- Dyson, F., 3-1
- e-commerce, 1-8
- e-mail server, control of, 3-16, 6-27
- economic systems, 1-9, 1-16, 3-41
- ecosystems, *see also* predator-prey system, 1-10, 4-25, 7-15
- eigenvalue assignment, 7-11, 7-13–7-17, 7-23, 8-12, 11-8, 11-23
  - by output feedback, 8-13
  - for observer design, 8-8
- eigenvalues, 5-11, 5-20, 5-29, 6-12, 9-5
  - and Jordan form, 6-9–6-11, 6-35
  - distinct, 5-35, 5-36, 6-8, 6-14, 8-23
  - dominant, 7-22
  - effect on dynamic behavior, 7-17–7-19, 7-21, 7-22, 9-5
  - for discrete-time systems, 6-35
  - invariance under coordinate transformation, 5-12
  - relationship to modes, 6-12–6-15
  - relationship to poles, 9-13
  - relationship to stability, 5-23, 6-10, 6-11
- eigenvectors, 5-12, 5-36, 6-12
  - relationship to mode shape, 6-13
- electric car, 14-5
- electric power, *see* power systems (electric)
- electrical circuits, *see also* operational amplifier, 3-7, 3-24, 4-10, 6-1, 9-6
- electrical engineering, 1-5–1-6, 3-4–3-5, 6-25, 10-9
- elephant, modeling of an, 3-1
- Elowitz, M. B., 3-39
- encirclement, *see also* Nyquist criterion, 10-5
- environmental science, 1-3, 1-6
- equation-based modeling, 3-7
- equilibrium points, 4-26, 5-6, 5-11, 6-2, 6-29, 7-2
  - bifurcations of, 5-28
  - discrete time, 3-41
  - for closed loop system, 7-11, 7-30
  - for planar systems, 5-10
  - region of attraction, 5-26–5-28, 5-34
  - stability, 5-8
- equipment protection, 14-8
- error feedback, 2-14, 11-1, 11-2, 11-19, 12-3
- estimators, *see* observers
- Euler integration, 3-20, 3-21
- exponential functions
  - simplified notation, 9-5
- exponential input, 9-3
- exponential signal, 9-4
- exponential signals, 9-2–9-9, 9-13, 9-24
- exponential signals  $\mathcal{E}$ , 9-5
- extended Kalman filter, 8-21
- extremal control, 14-1
- extremum seeking, 14-12
- Falb, P. L., 7-1
- Feedback, 2-1

- feedback, 1-1–1-3
    - as technology enabler, 1-3, 1-13
    - business, 1-16
    - combining with
      - feedforward, 2-29
    - drawbacks of, 1-3, 1-15, 11-18, 13-6, 13-13
    - economy, 1-16
    - in biological systems, *see also* biological circuits, 1-1–1-3, 1-10, 1-26, 11-5
    - in engineered systems, *see* control
    - in financial systems, 1-3
    - in nature, 1-3, 1-9–1-10, 4-25
    - positive, *see* positive feedback
    - properties, 1-3, 1-5, 1-11–1-17, 12-1, 12-6, 13-1
    - robustness through, 1-11
    - versus feedforward, 1-16, 11-4, 12-6
  - feedback and feedforward, 2-26
  - feedback connection, 9-19, 10-21
  - feedback controller, 9-20, 12-1
  - feedback decoupling, 14-3
  - feedback linearization, 6-32–6-33
  - feedback loop, 1-4, 10-1, 12-1, 13-12
  - feedback uncertainty, 13-3, 13-10
  - feedback:positive, 2-18
  - feedforward, 1-15, 1-16, 8-19–8-22, 9-20, 12-1, 12-5, 12-7
    - business, 1-16
    - combining with feedback, 2-29
    - difficulties, 2-27
    - economy, 1-16
    - sensitivity to process variations, 2-29
    - system inversion, 2-27
  - Fermi, E., 3-1
  - filters
    - active, 6-24
    - for disturbance weighting, 13-27
    - for measurement signals, 1-15, 8-26, 13-13
    - zz, *see also* band-pass filters; high-filters; low-pass filters
  - financial systems, *see* economic systems
  - finite escape time, 5-3
  - finite state machine, 1-22, 3-8, 4-5, 4-12
  - first-order systems, 6-4, 6-35, 9-10, 9-25, 9-27
  - fisheries management, 4-30
  - flatness, *see* differential flatness
  - flight control, 1-6, 1-13, 3-31, 6-33
    - X-29 aircraft, 12-27
    - zz, *see also* vectored thrust aircraft
  - flow, of a vector field, 3-3, 5-5
  - flow in a tank, 5-33
  - flow model (queuing systems), 3-33, 10-25, 11-24
  - flyball governor, *see* centrifugal governor
  - force feedback, 1-7
  - forced response, 6-3, 9-3
  - forced solution, 6-3
  - Forrester, J. W., 1-10
  - FOTD model, 11-11
  - Fourier, J. B. J., 3-40, 9-33
  - frequency domain, 9-1–9-3, 10-1, 10-19, 12-1
  - frequency response, 2-4, 3-5, 3-22, 3-23, 6-22–6-27, 9-2, 10-24, 11-11, 12-8
    - relationship to Bode plot, 9-24
    - relationship to Nyquist plot, 10-4, 10-5
  - second-order systems, 7-20, 9-29
  - system identification using, 9-31
- fully actuated systems, 9-14
- fundamental limits, *see* control: fundamental limitations
- Furuta pendulum, 5-36
- gain, 1-18, 2-4, 3-22, 4-8, 6-23, 6-24, 7-21, 9-3, 9-6, 9-13, 9-24, 10-12, 10-19–10-22, 13-1
  - $H_\infty$ , 10-20, 13-26
  - observer, *see* observer gain of a system, 10-19
  - reference, 7-30
  - state feedback, 7-11, 7-15, 7-30, 7-32
  - steady-state, 9-13
  - zero frequency, *see* zero frequency gain
  - zz, *see also* integral gain
- gain crossover frequency, 10-13, 12-8, 12-22, 13-19
- gain crossover frequency inequality, 12-22, 12-24
- gain curve (Bode plot), 9-24–9-28, 10-16, 12-13
- gain margin, 10-12–10-14
  - from Bode plot, 10-13
  - reasonable values, 10-14
- gain scheduling, 8-21, 13-28, 14-1, 14-11–14-12
- gain-bandwidth product, 4-10, 9-7, 13-15
- Gang of Four, 12-3, 12-35, 13-12
- Gang of Seven, 12-3, 12-8
- gene regulation, 1-10, 3-38, 6-36, 9-29
- general solution to the homogeneous equation, 2-2
- genetic switch, 3-43, 5-21
- global behavior, 5-10, 5-27–5-30
- Glover, K., 12-34, 13-28
- glucose regulation, *see* insulin-glucose dynamics
- Golomb, S., 4-1
- governor, *see* centrifugal governor
- $H_\infty$  control, 13-25–13-28, 13-30
- haptics, 2-25
- Harrier AV-8B aircraft, 3-32
- heat propagation, 9-9
- Heaviside, O., 6-34

- Heaviside step function, 6-20, 6-34
- Hellerstein, J. L., 1-26, 4-17
- high-frequency roll-off, 12-13, 13-13, 13-21
- high-pass filter, 9-29
- Hill function, 3-38
- Hoagland, M. B., 1-1
- Hodgkin-Huxley equations, 3-39
- homeostasis, 1-3, 3-38
- homogeneous equation, 2-2
- homogeneous solution, 6-3, 6-6
- Horowitz, I. M., 8-26, 12-34, 13-23, 13-28
- human-machine interface, 1-22, 4-1, 4-4
- hybrid system, 3-8, 3-19
- hysteresis, 1-17, 10-23
- identification, *see* system identification
- impedance, 9-7, 11-20
- impedance control, 2-25
- implementation, controllers, *see* analog implementation; computer implementation
- impulse function, 6-16, 6-34, 7-4
- impulse response, 6-5, 6-16, 6-17, 9-12
- inductor, transfer function for, 9-7
- inertia matrix, 3-12, 6-33
- infinity norm, 10-20, 13-26
- information systems, *see also* congestion control; web server control, 1-8, 3-33–3-37
- initial condition, 5-2, 5-5, 5-8, 6-2, 6-6, 6-7, 6-14, 8-15
- initial condition response, 6-3, 6-6–6-9, 6-12, 6-14, 6-17, 9-3
- initial value problem, 5-2
- inner loop control, 12-31, 12-33
- input sensitivity function, *see* load sensitivity function
- input/output models, *see also* frequency response; steady-state response; step response, 1-5, 3-4, 3-5, 6-2, 6-15–6-28, 9-1, 10-19 and transfer functions, 9-12 and uncertainty, 3-10, 13-3 from experiments, 9-31 relationship to state space models, 3-6, 5-1, 6-16 steady-state response, 6-19
- input/output stable, 10-20
- inputs, 3-3, 3-6
- insect flight control, 3-23–3-26
- instrumentation, 1-7, 4-7
- insulin-glucose dynamics, 1-2, 4-24–4-25
- integral action, 1-18, 1-19, 1-27, 2-20–2-21, 7-30–7-33, 11-1, 11-3–11-5, 11-7, 12-11 for bias compensation, 8-27 setpoint weighting, 11-19, 11-23 time constant, 11-2
- integral gain, 1-18, 11-2, 11-4, 11-7
- integrator, *see also* double integrator, 3-23, 3-24, 6-9, 7-30, 7-31, 8-5, 9-10, 9-25, 10-16, 11-16
- integrator windup, 1-18, 8-26, 11-14–11-16, 11-24, 11-25
- conditional integration, 11-25
- intelligent machines, *see* robotics
- internal model principle, 8-13, 8-21
- internal stability, 12-4
- Internet, *see also* congestion control, 1-8, 1-9, 4-11, 4-13, 4-16, 4-29
- Internet Protocol (IP), 4-13
- invariant set, 5-25, 5-28
- inverse, 2-27
- inverse model, 6-32, 12-6
- inverse response, 2-28, 10-18, 10-26
- inverted pendulum, *see also* balance systems, 3-13–3-14, 4-5, 5-6, 5-14, 5-25, 5-27, 5-35, 5-36, 10-10, 12-27
- Jacobian linearization, 6-29–6-31
- Janert, P. K., 1-26
- Jordan block, 6-9
- Jordan form, 6-9–6-12, 6-35, 7-22
- Kalman, R. E., 7-1, 7-32, 8-1, 8-23, 8-26
- Kalman decomposition, 8-22–8-24, 9-17, 9-34, 9-36
- Kalman filter, 8-14–8-19, 8-26, 13-25 extended, 8-21
- Kalman-Bucy filter, 8-17
- Kelly, F. P., 4-16
- Kepler, J., 3-2
- Keynesian economic model, 3-41, 6-35
- Krasovski-Lasalle principle, 5-24–5-25
- LabVIEW, 5-29, 6-34
- lag, *see* phase lag
- lag compensation, 12-13–12-15
- Laplace transform computing transfer function with, 9-11
- Laplace transforms, xi, 9-10–9-12
- Laplacian matrix, 3-37
- Lasalle's invariance principle, *see* Krasovski-Lasalle principle
- lead, *see* phase lead
- lead compensation, 12-14–12-17, 12-32, 12-36
- limit cycle, 4-27, 5-7, 5-16, 5-17, 5-29, 10-22
- linear quadratic control, 7-25–7-29, 8-16, 8-26, 13-24–13-25
- linear systems, 3-4, 3-10, 4-10, 5-11, 6-1–6-34, 8-22, 9-4, 9-33, 10-20



- linear time-invariant systems,
  - 3-4, 3-10, 6-4
- linearity, 6-3, 9-24
- linearization, 5-15, 5-23, 6-2, 6-28–6-33, 8-20, 8-21, 13-1
- Lipschitz continuity, 5-4
- load disturbances, *see also*
  - disturbances, 12-1, 13-13
- load sensitivity function, 12-3
- local behavior, 5-9, 5-15, 5-24, 5-27, 6-29
- locally asymptotically stable, 5-9
- logistic growth model, 4-25, 4-26, 4-30
- loop analysis, 10-1, 12-1
- loop gain, 10-12
- loop shaping, 10-4, 12-12–12-17, 12-33, 13-23
  - design rules, 12-14
  - fundamental limitations, 12-21–12-30
  - zz, *see also* Bode's loop transfer function
- loop transfer function, *see also*
  - Bode's loop transfer function, 10-1–10-4, 10-12, 10-20, 12-1, 12-4, 12-12, 12-13, 12-16, 12-26, 12-34
- Lotus Notes server, *see* e-mail server
- low-order models, 11-6
- low-pass filter, 9-29, 11-19
- LQ control, *see* linear quadratic control
- LTI systems, *see* linear time-invariant systems
- Lyapunov equation, 5-20, 5-35
- Lyapunov functions, 5-17, 5-18, 5-20, 5-21, 5-27, 5-34, 6-35
  - design of controllers using, 5-25, 5-31
  - existence of, 5-20
- Lyapunov stability analysis, 3-22, 5-17–5-26, 5-33
  - discrete time, 5-35
- magnitude, 2-4
- manifold, 5-26
- margins, *see* stability margins
- materials science, 1-6
- Mathematica, 3-20, 5-29, 6-34
- MATLAB, 1-27, 3-20, 5-29, 6-34, 7-34
  - acker, 7-15, 8-11
  - dlqe, 8-16
  - dlqr, 7-29
  - hifsyn, 13-26
  - jordan, 6-10
  - linmod, 6-30
  - lqr, 7-25
  - place, 7-15, 7-24, 8-11
  - trim, 6-30
- matrix exponential, 6-6–6-9, 6-13, 6-15, 6-33, 6-34
  - coordinate transformations, 6-18
  - Jordan form, 6-10
  - second-order systems, 6-34
- maximum complementary sensitivity, 13-8, 13-19
- maximum selector, 1-20, 14-8
- maximum sensitivity, 12-10, 13-6, 13-20
- measured signals, 3-6, 3-10, 5-1, 8-1, 8-14, 8-26, 12-2, 12-4, 13-25
- measurement noise, 1-4, 1-15, 8-1, 8-3, 8-14, 8-15, 8-17, 9-20, 11-18, 12-1–12-3, 12-13, 13-13
  - response to, 12-11–12-12, 13-13–13-14
- mechanical systems, 3-6, 3-12, 3-21, 3-30, 3-40, 6-32
- mechanics, 3-2–3-3, 3-5, 5-32, 6-1
- median selector, 14-9
- mid-range control, 14-1, 14-7
- minimal model
  - (insulin-glucose), *see also* insulin-glucose dynamics, 4-24, 4-25
- minimum phase, 10-17, 10-24, 12-21
- minimum selector, 1-20, 14-8
- model following, 14-1
- Modelica, 3-7
- modeling, 1-5, 3-1–3-10, 3-40, 4-1
  - control perspective, 3-5
  - discrete control, 3-35
  - discrete-time, 3-14–3-15, 6-27–6-28
  - frequency domain, 9-1–9-3
  - from experiments, 3-27–3-28
  - model reduction, 1-5
  - normalization and scaling, 3-28
  - of uncertainty, 3-9–3-10
  - simplified models, use of, 3-6, 11-7, 13-2, 13-8, 13-9
  - software for, 3-7, 6-30, 6-33
  - state space, 3-10–3-22
  - uncertainty, *see* uncertainty
- modes, 6-12–6-14, 9-13
  - relationship to poles, 9-14
- monotone step responses, 11-11
- motion control systems, 3-30–3-33, 8-26
- motors, electric, 3-44, 7-34, 8-28
- multi-input, multi-output systems, *see also*
  - input/output models, 10-20, 12-4, 12-14
- multiplicative uncertainty, 13-3, 13-10
- nanopositioner (AFM), 10-15, 13-20
- natural frequency, 7-19
- negative definite function, 5-18
- negative feedback, 1-12, 1-16, 4-9, 7-10, 10-1, 11-5
- Nernst's law, 3-40
- networking, *see also*
  - congestion control, 1-8, 3-24, 4-16
- neural systems, 1-7, 3-25, 3-39, 11-5, 11-6
- neutral stability, 5-8–5-10
- Newton, I., 3-2
- Nichols, N. B., 6-33, 11-10, 12-33
- Nichols chart, 13-24
- Nobel Prize, 1-7, 3-40, 4-17
- noise, *see* disturbances;
  - measurement noise

- noise attenuation, 9-30,  
12-11–12-12
- noise cancellation, 5-31
- noise sensitivity function, 12-3
- nonlinear systems, 3-6, 5-1,  
5-4, 5-7, 5-15, 5-17, 5-21,  
5-27–5-32, 8-2, 8-20,  
8-21, 10-20, 10-21
- linear approximation, 5-15,  
5-23, 6-29, 13-1
- system identification, 3-42
- nonminimum phase, *see also*  
inverse response, 10-16,  
10-17, 10-26,  
12-21–12-23
- nonunique solutions (ODEs),  
5-3
- normalized coordinates,  
3-28–3-30, 3-42, 6-31
- norms, 10-19–10-20
- Nyquist, H., 10-1, 10-23
- Nyquist criterion, 10-5, 10-7,  
10-9, 10-12, 10-20, 10-21,  
11-11
- for robust stability, 13-6,  
13-31
- Nyquist D contour, 10-4,  
10-10
- Nyquist plot, 10-4–10-5,  
10-12, 10-13, 11-11,  
12-10, 13-24
- observability, 3-6, 8-1–8-2,  
8-22, 8-26
- rank condition, 8-3
- tests for, 8-2–8-3
- unobservable systems, 8-4,  
8-22–8-24, 9-36
- observability matrix, 8-3, 8-5
- observable canonical form,  
8-4, 8-5, 8-27
- observer gain, 8-7, 8-9–8-11,  
8-13, 8-15–8-17
- observers, 8-1, 8-6–8-9, 8-17,  
8-21
- block diagram, 8-2, 8-10
- zz, see also* Kalman filter
- ODEs, *see* differential  
equations
- Ohm's law, 3-40, 4-9, 9-6
- on-off control, 1-17, 1-18
- open loop, 1-1, 1-2, 4-8, 7-2,  
9-22, 10-1, 11-14, 12-1,  
12-10, 13-3
- open loop gain, 9-7, 12-8
- operational amplifiers,  
4-7–4-11, 9-7, 11-20,  
13-10
- circuits, 4-28, 6-24, 10-2,  
13-14
- dynamic model, 4-10, 9-7
- input/output characteristics,  
4-8
- oscillator using, 4-28, 5-35
- static model, 4-8, 9-7
- optimal control, 7-25, 8-15,  
8-17, 13-25
- order, of a model, 3-10, 3-11
- ordinary differential equations,  
*see* differential equations
- oscillator dynamics, 4-28, 5-2,  
5-3, 6-7, 6-8, 7-18, 9-5,  
9-10
- normal form, 3-42
- zz, see also* nanopositioner  
(AFM); spring-mass  
system
- outer loop control,  
12-31–12-33
- output feedback, *see also*  
control: using estimated  
state; loop shaping; PID  
control, 8-11, 8-12, 8-26
- output sensitivity function, *see*  
noise sensitivity function
- outputs, *see* measured signals
- overdamped oscillator, 7-18
- overshoot, 6-21, 7-10, 7-20,  
12-8
- P control, 2-9, 2-10
- Padé approximation, 10-26,  
12-23
- paging control (computing),  
3-35
- pairing problem, 14-2
- parallel connection, 9-19
- parallel systems, 14-5–14-6
- parametric stability diagram,  
5-28–5-30
- parametric uncertainty, 3-9,  
13-1
- particular solution, *see also*  
forced response, 2-2, 6-3,  
6-22, 9-5
- non  
uniqueness, 2-2
- transfer function, 2-3
- passive systems, 10-21, 12-26
- passivity theorem, 10-21
- patch clamp, 1-7
- PD control, 2-24, 11-4, 12-14,  
12-15
- peak frequency, 6-26, 12-8
- pendulum dynamics, *see also*  
inverted pendulum, 5-19
- perfect adaptation, 11-5
- perfect control, 14-2
- performance, 4-12
- performance limitations,  
12-21, 12-26, 13-20,  
13-27
- due to right half-plane poles  
and zeros, 10-17
- zz, see also* control:  
fundamental limitations
- performance specifications,  
*see also* overshoot;  
maximum sensitivity;  
resonant peak; rise time;  
settling time, 6-21, 7-10,  
12-1, 12-8–12-12, 12-14,  
13-12
- periodic solutions, *see*  
differential equations;  
limit cycles
- persistence, of a web  
connection, 4-12, 4-13
- Petri net, 3-24
- pharmacokinetics, *see also*  
drug administration, 4-21,  
4-25
- phase, *see also* minimum  
phase; nonminimum  
phase, 2-4, 3-22, 6-23,  
6-24, 7-21, 9-3, 9-6, 9-24,  
10-22
- minimum vs. nonminimum,  
10-16
- phase crossover frequency,  
10-13
- phase curve (Bode plot),  
9-24–9-26, 9-28
- relationship to gain curve,

- 10-16, 12-13
- phase lag, 6-23, 6-24, 9-29, 10-17, 12-22, 12-24
- phase lead, 6-23, 9-29, 12-17, 12-36
- phase margin, 10-13, 10-14, 12-14, 12-15, 12-22, 12-37, 13-29
  - from Bode plot, 10-13
  - reasonable values, 10-14
- phase portrait, 3-3, 5-4–5-6, 5-27
- Philbrick, G. A., 4-11
- photoreceptors, 11-5
- physics, relationship to control, 1-5
- PI Control, 2-9
- PI control, 1-12, 1-19, 2-10, 2-21, 4-1, 4-4, 11-4, 11-9, 12-14, 12-15
  - first-order system, 11-7, 13-18
- PID control, 1-18–1-19, 11-1–11-23, 12-17
  - block diagram, 11-2, 11-4, 11-16
  - computer implementation, 11-21
  - ideal form, 11-1, 11-23
  - implementation, 11-4, 11-18–11-23
  - in biological systems, 11-5
  - op amp implementation, 11-20–11-21
  - tuning, 11-10–11-14
  - zz, *see also* derivative action; integral action
- pitchfork bifurcation, 5-37
- planar dynamical systems, *see also* second-order systems, 5-5, 5-10
- pole and zeros, 9-13–9-16
- pole excess, 12-18
- pole placement, *see also* eigenvalue assignment, 7-11, 13-16, 13-19–13-20
  - robust, 13-15
- pole zero diagram, 9-14
- pole/zero cancellations, 9-16–9-18, 9-36, 13-20
- poles, 2-5, 9-13, 9-14
  - dominant, *see also* dominant eigenvalues (poles), 11-9
  - fast stable, 13-18, 13-20
  - pure imaginary, 10-5, 10-10
  - relationship to eigenvalues, 9-13
  - right half-plane, 9-14, 10-10, 10-17, 12-21, 12-23–12-24, 12-26, 12-36, 13-20
- poles and zeros, 9-13
- population dynamics, *see also* predator-prey system, 4-25–4-27, 4-30
- positive definite function, 5-18, 5-20, 5-24
- positive definite matrix, 5-20, 7-25
- positive feedback, 1-15–1-17, 2-18, 2-21, 5-36, 11-4
- positive real (transfer function), 12-26
- power of a matrix, 6-6
- power systems (electric), 1-5–1-6, 3-43, 5-7, 5-34
- predator-prey system, 3-15, 4-26–4-27, 5-28, 7-15
- prediction, in controllers, *see also* derivative action, 1-18, 1-19, 8-21, 11-5, 13-29
- prediction time, 11-5
- principle of the argument, *see* variation of the argument, principle of
- process control, 1-6, 3-24
- proportional (P) control, 2-9
- proportional control, *see also* PID control, 1-18, 2-9, 11-1
- proportional, integral, derivative control, *see* PID control
- proportional-derivative (PD) controller, 2-24
- Proportional-Integral Control, 2-9
- protocol, *see* congestion control; consensus
- pulse signal, *see also* impulse function, 6-16, 6-17, 7-22
- pupil response, 9-32, 11-5
- pure exponential solution, 9-5
- Q-value, 3-42, 7-20, 9-27
- quantitative feedback theory (QFT), 13-23–13-24
- quarter car model, 9-37
- queuing systems, 3-33–3-35, 3-43
- random process, 3-33, 8-14, 8-15, 8-29
- reachability, 3-6, 7-1–7-9, 7-32, 8-22
  - rank condition, 7-4
  - tests for, 7-3
  - unreachable systems, 7-5, 7-33, 8-22–8-24, 9-36
- reachability matrix, 7-3, 7-8
- reachable canonical form, 3-11, 7-6–7-9, 7-13, 7-14, 7-33
- reachable set, 7-1
- real-time systems, 1-5
- reference signal, *see also* command signals; setpoint, 1-17, 7-10, 9-1, 9-20, 11-1, 11-19, 12-3, 12-5
  - effect on observer error, 8-12, 8-19, 8-24
  - response to, 12-8, 12-9, 12-35
  - tracking, 7-10, 8-19, 8-20, 12-13, 13-14
- reference weighting, *see* setpoint weighting
- region of attraction, *see* equilibrium points; regions of attraction
- regulation problem, 2-8
- regulator, *see* control law
- relay feedback, 10-23, 11-13
- Reno (protocol), *see* Internet; congestion control
- repetitive control, 14-1, 14-9, 14-10
- repressilator, 3-39
- repressor, 1-11, 3-39, 3-43, 5-21, 6-36, 9-30
- reset logic, 3-8
- reset, in PID control, 11-3, 11-4
- resonant frequency, 7-20, 10-20

- resonant peak, 6-26, 7-20, 12-8, 13-9
- resource usage, in computing systems, 3-34, 3-36, 4-11, 4-12
- response, *see* input/output models
- retina, *see also* pupil response, 11-5
- Riccati equation, 7-25, 8-17, 13-26, 13-28
- Riemann sphere, 13-5
- right half-plane poles and zeros, *see* poles: right half-plane; zeros: right half-plane
- rise time, 6-21, 7-10, 7-20, 12-8
- robotics, 1-7–1-8, 6-33
- robustness, 1-10–1-12, 12-8, 13-3, 13-28
  - performance, 13-12–13-15, 13-22–13-28
  - stability, 13-6–13-12
  - using gain and phase margin, 10-14, 12-13
  - using maximum sensitivity, 12-10, 12-13, 13-7, 13-29, 13-31
  - using pole placement, 13-15–13-22
  - via gain and phase margin, 10-14
  - zz*, *see also* uncertainty
- roll-off, *see* high-frequency roll-off
- root locus, 12-17, 12-18
  - asymptotes, 12-36
  - initial direction, 12-36
  - real line segment, 12-36
- root locus diagram, 5-29, 5-30
- root locus method, 12-18
- Routh-Hurwitz criterion, 2-5, 5-37
- Routh-Hurwitz stability criterion, 2-5
- rush-hour effect, 3-35, 3-43
- saddle (equilibrium point), 5-10
- sampling, 6-27, 8-25, 8-26, 11-21
- saturation function, *see also* actuators: saturation, 3-24, 4-8, 11-21
- scaling, *see* normalized coordinates
- scanning tunneling microscope, 4-17
- schematic diagrams, 3-23, 3-24, 4-7
- Schitter, G., 4-20
- second-order systems, 3-2, 6-34, 7-18–7-21, 7-35, 9-26, 9-27, 11-9
- Segway, 2-24
- Segway Personal Transporter, 3-12, 7-4
- selector, 1-20
- selector control, 14-1, 14-8–14-9
  - of air-fuel, 1-20
- selector, maximum, 1-20
- selector, minimum, 1-20
- self-activation, 5-36
- self-optimization, 14-12
- self-repression, 6-36, 9-29
- semidefinite function, 5-18
- sensitivity crossover frequency, 12-10
- sensitivity function, 12-3, 12-10, 12-11, 12-13, 12-26, 13-7, 13-14, 13-20
  - and disturbance attenuation, 12-10, 12-26, 12-35
- sensor matrix, 3-11, 3-14
- sensor networks, 3-36
- sensors, 1-3, 1-4, 8-2, 8-25, 10-17, 11-21, 12-1, 12-4, 12-23, 12-24, 13-25
  - effect on zeros, 10-17, 12-24
  - in computing systems, 4-11
  - zz*, *see also* measured signals
- separation principle, 8-1, 8-13
- series connection, 9-19
- service rate (queuing systems), 3-33
- servo problem, 2-12
- setpoint, 11-1
- setpoint weighting, 11-19, 11-23
- settling time, 6-21, 6-35, 7-10, 7-20, 12-8
- similarity of two systems, 13-3–13-6
- simplified notation
- exponential functions, 9-5
- simulation, 3-10, 3-19–3-20
- SIMULINK, 6-30
- single-input, single-output (SISO) systems, 5-1, 6-2, 6-3, 6-29, 8-4, 10-20
- singular values, 10-19, 10-20, 13-30
- sink (equilibrium point), 5-10
- small gain theorem, 10-20–10-21, 13-9
- Smith predictor, 13-29
  - ideal time delay, 14-10
- social, 1-16
- software tools for control, x
- solution (ODE), *see* differential equations: solutions
- source (equilibrium point), 5-10
- spectrum analyzer, 9-31
- Sperry autopilot, 1-13
- split-range control, 14-7
- spring-mass system, 3-2, 3-19, 3-21, 3-22, 4-18, 5-34
  - coupled, 6-14, 6-18
  - generalized, 3-12, 4-7
  - identification, 3-27
  - normalization, 3-28, 3-42
  - zz*, *see also* oscillator dynamics
- Stability, 2-5
  - Rout-Hurwitz criterion, 2-5
- stability, 1-3, 1-5, 1-12, 1-13, 2-5, 3-21, 5-4, 5-8–5-26
  - asymptotic stability, 5-8, 5-13
  - conditional, 10-9
  - in the sense of Lyapunov, 5-8
  - local versus global, 5-9, 5-16, 5-27
  - Lyapunov analysis, *see* Lyapunov stability analysis
  - neutrally stable, 5-8, 5-10
  - of a system, 5-11
  - of equilibrium points, 3-21, 5-8, 5-10, 5-17, 5-18, 5-23

- of feedback loop, *see*
  - Nyquist criterion
- of limit cycles, 5-16
- of linear systems,
  - 5-11–5-14, 5-20, 6-10
- of solutions, 5-8, 5-9, 5-17
- of transfer functions, 9-14
- robust, *see* robust stability
- unstable solutions, 5-9
- using eigenvalues, 5-23, 6-10, 6-11
- using linear approximation, 5-14, 5-23, 6-30
- using Routh-Hurwitz criterion, 5-37
- using state feedback, 7-9–7-29
- zz*, *see also* bifurcations; equilibrium points
- stability diagram, *see* parametric stability diagram
- stability margin (quantity), 10-13, 10-14, 12-10, 12-37, 13-7, 13-26
  - reasonable values, 10-14
- stability margins (concept), 10-12–10-16, 10-25, 12-13
- stable, 2-5
- stable pole, 9-14
- stable zero, 9-14
- Stark, L., 9-32
- state, of a dynamical system, 3-2, 3-6, 3-10
- state estimators, *see* observers
- state feedback, *see also* eigenvalue assignment; linear quadratic control, 7-1–7-32, 8-7, 8-12, 8-19–8-21, 8-24–8-26, 13-16, 13-25, 14-4
- state space, 3-2, 3-10–3-22, 7-9
- state vector, 3-2, 3-10
- static gain, 2-4
- steady state solution, 9-5
- steady-state gain, *see* zero frequency gain, 9-13
- steady-state response, 1-27, 3-20, 6-19–6-27, 7-11, 7-20, 9-2, 9-31, 9-33
- steam engines, 1-2, 1-11
- steering, *see* vehicle steering
- Stein, G., xii, 1-1, 12-1, 12-27
- step input, 3-4, 6-5, 6-20, 9-13
- step response, 3-4, 3-5, 3-27, 3-28, 6-5, 6-17, 6-20, 6-21, 7-10, 7-19, 7-20, 11-10
- stochastic systems, 8-14, 8-17
- summing junction, 3-24
- superposition, 3-4, 6-3, 6-17, 6-34, 9-2
- supervisory control, *see* decision making: higher levels of
- supply chains, 1-9, 1-10
- supremum (sup), 10-20
- switching behavior, 1-16, 3-43, 5-23, 5-24, 13-28
- system identification, 3-27, 3-28, 3-42, 9-31
- system inversion, 2-27
- tapping mode, *see* atomic force microscope
- TCP/IP, *see* Internet; congestion control
- Teorell, T., 4-21, 4-25
- the relative gain array, 14-3
- three-term controllers, *see also* PID control, 11-1
- thrust vectored aircraft, *see* vectored thrust aircraft
- time constant, 2-2
- time constant, first-order system, 6-35
- time delay, 1-8, 9-9, 9-10, 10-15, 10-17, 11-10, 11-11, 11-21, 12-23, 12-24
  - compensation for, 13-29, 13-30
  - Padé approximation, 10-26, 12-23
- time plot, 3-3
- time-invariant systems, 3-4, 3-10, 5-33, 6-4–6-5
- tracking, *see* reference signal: tracking
- tracking mode, 11-17
- trail (bicycle dynamics), 4-6
- transcription factors, 3-38
- transcriptional regulation, *see* gene regulation
- transfer function, 2-3
- transfer function: loop tracing, 9-21
- transfer functions, 9-1–9-33
  - common systems, 9-10
  - derivation using exponential signals, 9-4
  - for control systems, 9-20, 9-36
  - for electrical circuits, 9-6
  - for time delay, 9-9
  - frequency response, 9-2, 9-24
  - from experiments, 9-31
  - irrational, 9-9
  - linear input/output systems, 9-4, 9-10, 9-36
  - simplified notation, 9-5
- transfer functions: , 9-12
- transfer functions: Laplace transforms, 9-11
- transfer functions: impulse response, 9-12
- transfer functions: state space model, 9-11
- transient response, 3-20, 6-20, 6-21, 6-23, 7-2, 7-23
- Transmission Control Protocol (TCP), 4-13
- transmission zero, 2-5
- Tsien, H. S., 1-8
- tuning rules, *see* Ziegler-Nichols tuning, 11-24
- Tustin, A., 2-1
- two degree-of-freedom control, 8-20, 11-2, 12-5, 12-7, 12-34, 12-35
- two degrees of freedom, 2-14, 2-30
- uncertainty, 1-4, 1-11–1-12, 3-6, 3-9–3-10, 7-30, 13-1–13-6
  - component or parameter variation, 1-4, 3-9, 13-1
- disturbances and noise, 1-4, 3-6, 7-10, 9-20, 12-1
- unmodeled dynamics, 1-4, 3-9, 13-2, 13-8

- zz, *see also* additive
  - uncertainty; feedback
  - uncertainty; multiplicative
  - uncertainty
- uncertainty band, 3-9
- uncertainty lemon, 3-9, 4-4, 4-10, 4-20
- undamped natural frequency, 2-11
- underdamped oscillator, 5-3, 7-19, 7-20
- unit step, 6-20
- unmodeled dynamics, *see*
  - uncertainty: unmodeled dynamics, 2-11, 2-12
  - effect for control, 2-12
- unstable pole, *see* poles: right half-plane
- unstable pole/zero
  - cancellation, 9-17
- unstable solution, for a
  - dynamical system, 5-9, 5-10, 5-13, 6-10, 9-14
- unstable zero, *see* zeros: right half-plane
  
- variation of the argument,
  - principle of, 10-11, 10-24
- vector field, 3-3, 5-5
- vectored thrust aircraft, 3-32–3-33, 6-11, 7-26, 8-17, 9-36, 12-16, 12-30
- vehicle steering, 3-30–3-32, 6-30, 7-11, 8-9, 8-13, 8-21, 9-22, 10-18, 10-25, 12-7, 13-16
  - ship dynamics, 3-30
- vehicle suspension, *see also*
  - coupled spring-mass system, 9-37
- vertical takeoff and landing, *see* vectored thrust aircraft
- vibration absorber, 9-38
- Vinnicombe, G., 12-34, 13-5, 13-6, 13-28
- Vinnicombe metric, 13-3–13-6, 13-26
- voltage clamp, 1-7, 3-40
  
- waterbed effect, 12-26, 12-27
- Watt governor, *see* centrifugal governor
- Watt steam engine, 1-3, 1-11
- web server control, 4-11–4-13, 7-27
- web site, companion, x
- Whipple, F. J. W., 4-7
- Wiener, N., 1-7
- winding number, 10-11
- window size (TCP), 4-14, 4-16, 5-10
- windup, *see* integrator windup
  - cascade control, 14-5
  - selector control, 14-9
- Wright, W., 1-13
  
- Wright Flyer, 1-6, 1-13
  
- X-29 aircraft, 12-27
  
- Youla parameterization, 13-10–13-12
  
- zero
  - blocking property, 2-5
- zero frequency gain, 2-4, 6-25, 7-11, 7-14, 7-20, 9-13, 11-11
- zeros, 2-5, 9-13
  - Bode plot for, 9-36
  - effect of sensors and actuators on, 10-17, 10-18, 12-24
  - for a state space system, 9-14
  - right half-plane, 9-14, 10-17, 12-21–12-24, 12-27, 12-36, 13-20
  - signal-blocking property, 9-13
  - slow stable, 13-16, 13-18, 13-20
- Ziegler, J. G., 11-10, 11-23
- Ziegler-Nichols tuning, 11-10–11-13, 11-23
  - frequency response, 11-11
  - improved method, 11-11
  - step response, 11-10